

# Automatic Braking System Using Ultrasonic Sensor

Prof S. S. Patil<sup>1</sup>, Kartik Aher<sup>2</sup>, Aditya Kulkarni<sup>3</sup>

Professor, Department of Mechanical Engineering<sup>1</sup>

Students, Department of Mechanical Engineering<sup>2,3</sup>

All India Shri Shivaji Memorial Society's College of Engineering, Pune, Maharashtra, India

**Abstract:** When compared with olden days life span of human is reduced. Death rate due to accident is drastically increased because vehicles usage is increasing by day by day. Due to brake failure so many accidents are occurring so when we control the brake by automatically we can reduce the effect of accident. A Ultrasonic setup is placed in front of vehicle and that setup consists of an emitter and a receiver. Ultrasonic emitter always emits the ultrasonic waves, whenever a obstacle is detected then wave gets reflected and receiver receives the signal. Reflected wave sends the signal to the Aurduino Nano from that based upon distance of object it actuates the buzzer or brakes. Brakes are actuated by using Solenoid valve. Solenoid valve operated by electrical signal and it actuates brakes by using pneumatics. UBS car provides the glimpse into the future of automotive safety. By UBS system we can prevent more accidents and save more lives.

**Keywords:** Braking system, Ultrasonic sensor, Aurduino.

## I. INTRODUCTION

The first demonstration of forward collision avoidance was performed in 1995 by a team of scientists and engineers at Hughes Research Laboratories in Malibu, California. The project was funded by Delco Electronics, and was led by HRL physicist Ross D. Olney. A small custom fabricated radar-head was developed specifically for this automotive application at 77 GHz. The forward radar-head, plus the signal processing unit and visual-audio-tactile feedbacks were first integrated into a Volvo S40, and shortly thereafter into a Cadillac STS.

### N.H.A.I Report

According to the N.H.A.I data of number of accidents occurred during the 2011 analysis. Accidents 4.97 lakh (annual) i.e. (1 every minute) and the deaths for the accidents are recorded as 1,42,485

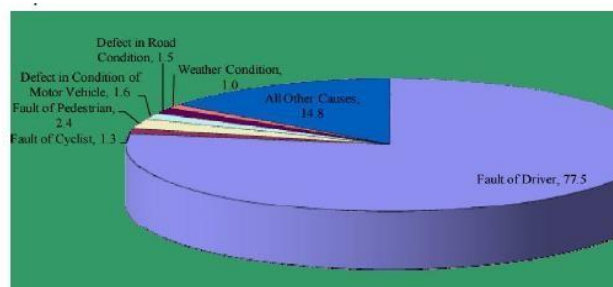

Fig.1. Causes of accidents in 2011 analysis (Courtesy by N.H.A.I)

### Introduction to Braking

A Brake is a mechanical device used to slowing or stopping a moving vehicle i.e. wheel, axle, or to prevent its motion, most often accomplished by means of friction.

### Stopping distance consists of three factors:

- Driver's reaction time
- Brake lag
- Braking distance

### Design and Function

Air brake system is used heavy vehicles because they need higher impact of braking . Piston cylinder arrangement is made for braking. Compressed air is used to hit the brakes, forthat a compressor is provided in the vehicles. Braking time is small and less by using pneumatics in heavy vehicles.[2]

### Design and Construction

Depending on the specimen specification, there are multiple forms of body constructions:

Tie rod cylinders: The most common cylinder constructions that can be used in many types of loads. Has been proven to be the safest form.

Flanged-type cylinders: Fixed flanges are added to the ends of cylinder, however, this form of construction is more common in hydraulic cylinder construction.

### Hand operated lever

Directional control valves(hand operated value) are one of the most fundamental parts in hydraulic machinery as well as pneumatic machinery. They allow fluid flow into different paths from one or more sources. They usually consist of a spool inside a cylinder which is mechanically or electrically controlled.



Fig 2 Hand operated directional valve

## II. BRAKING CIRCUIT

In this project major part of work comes from electronics to actuate the solenoid valve. Because solenoid valve is an electromagnetic component which is used to actuate the brake cylinders. The components used in the circuit are listed in below:

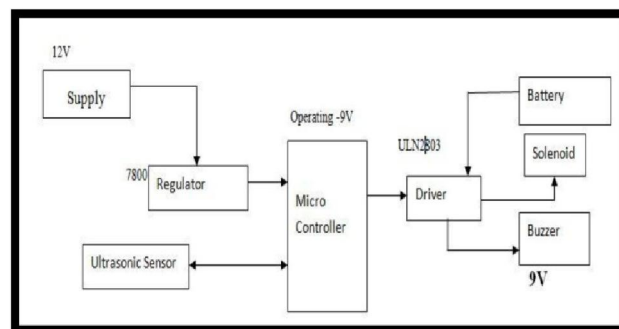

Fig 3 Circuit diagram of the braking circuit

Analog electronic circuits are those in which current or voltage may vary continuously with time to correspond to the information being represented. Analog circuitry is constructed from two fundamental building blocks: series and parallel circuits. In a series circuit, the same current passes through a series of components. A string of Christmas lights is a good example of a series circuit: if one goes out, they all do. In a parallel circuit, all the components are connected to the same voltage, and the current divides between the various components according to their resistance.

### 2.1 Ultrasonic Transducers

Ultrasonic transducers are used to emit the ultrasonic waves with high frequency. These transducers are operated by using electrical current. In this project 12V battery is used switch on the source. [3]

Distance=Time x Speed of Sound divided by 2

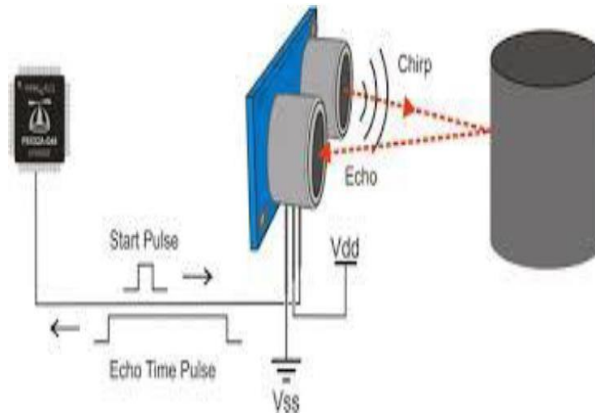

Time = the time between when an ultrasonic wave is transmitted and when it is received you divide this number by 2 because the sound wave has to travel to the object and back.

### Ardunio Nano

The Arduino Nano is a small, complete, and breadboard-friendly board based on the ATmega328 (ArduinoNano 3.x). It has more or less the same functionality of the Arduino Duemilanove, but in a different package. It lacks only a DC power jack, and works with a Mini-B USB cable instead of a standard one.

### Power

The Arduino Nano can be powered via the Mini-B USB connection, 6-20V unregulated external power supply (pin30), or 5V regulated external power supply (pin 27). The power source is automatically selected to the highest voltage source.

### Memory

The ATmega328 has 32 KB, (also with 2 KB used for the bootloader). The ATmega328 has 2 KB of SRAM and 1 KB ofEEPROM.

### Input and Output

Each of the 14 digital pins on the Nano can be used as an input or output, using pinMode(), digitalWrite(), and digitalRead() functions. They operate at 5 volts. Each pin can provide or receive a maximum of 40 mA and has an internal pull-up resistor (disconnected by default) of 20-50 kOhms. In addition, some pins have specialized functions.[4]

### Communication

The Arduino Nano has a number of facilities for communicating with a computer, another Arduino, or other microcontrollers. The ATmega328 provide UART TTL (5V) serial communication, which is available on digital pins 0 (RX) and 1 (TX). An FTDI FT232RL on the board channels this serial communication over USB and the FTDI drivers (included with the Arduino software) provide a virtual com port to software on the computer. The Arduino software includes a serial monitor which allows simple textual data to be sent to and from the Arduino board. The RX and TX LEDs on the board will flash when data is being transmitted via the FTDI chip and USB connection to the computer (but not for serial communication on pins 0 and 1).

### Program Used For Micro Controller

```
const int trigPin = 3; const int echoPin = 2; const int solenoid = 5; const int buzzer = 6; void setup()
{
Serial.begin(9600); pinMode(trigPin, OUTPUT); pinMode(echoPin, INPUT);
```

```
pinMode(solenoid, OUTPUT);pinMode(buzzer, OUTPUT);
}
void loop()
{
long duration, cm;
digitalWrite(trigPin, LOW);
delayMicroseconds(2);
digitalWrite(trigPin, HIGH);
delayMicroseconds(10);
digitalWrite(trigPin, LOW);
duration = pulseIn(echoPin, HIGH);cm = duration/ 29 / 2;
Serial.println(cm);
if(cm<100)
{digitalWrite(solenoid,1);
digitalWrite(buzzer,1);delay(2000);
}
else {digitalWrite(solenoid,0);digitalWrite(buzzer,0);} delay(200);
```

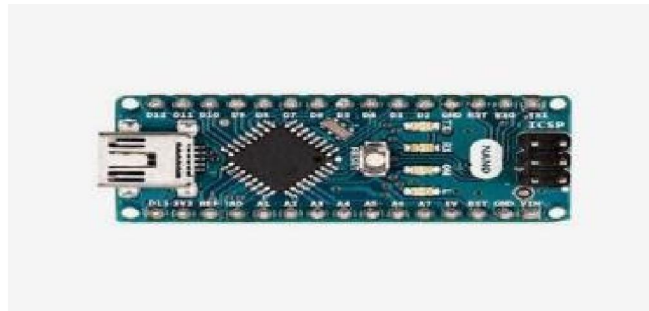

Fig 4. Arduino Nano

### Driver

The ULN2803APG / AFWG Series are high-voltage, high-current darlington drivers comprised of eight NPN Darlington pairs. All units feature integral clamp diodes for switching inductive loads. Applications include relay, hammer, lamp and display (LED) drivers.

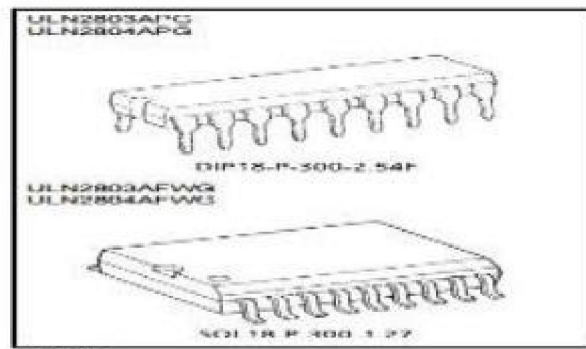

Fig 5 Driver

### 3/2 way solenoid valves

Solenoid valve is a device which is used to control the direction of air by using electrical current. The solenoid valve consists of one input and two outputs. Solenoid valve connects in between air reservoir and brakes to apply brakes. When ever signal achieved from circuit the valve changes its direction and air flows to brakes. When the switch is off condition the direction changes to reverse of braking. [5]

### III. LITARATURE REVIEW

In automation field, designers have proposed several enhancements A precise shortrange radar system was developed for anti -collision applications where automatic braking is applied in response to detection of a collision risk where a very high probability of detection is accompanied by a very low level of false alarms. A brake strategy for an automatic parking system of vehicle has proposed brake controller which work with the automatic parking system and make the process of parking smooth and stable. Autonomous antilock braking system (ABS) system which can take over the traction control of the vehicle is developed for a fourwheel vehicle. ABS is a braking system that maintains control over the directional stability of the vehicle during emergency braking or braking on slippery roads by preventing wheel lock-up. There have been considerable advances in modern vehicle braking systems in recent years.

#### *A. Implementation of Automatic Reverse Braking System, FPGA Divya Thakur Prof. A. P. Thakare*

Auto-Braking System using Sensor was proposed to prevent front-end, rear-end, right-turn and left -turn accidents on roads. This module can detect the distance between front vehicle and driver's vehicle to keep a constant distance using a sensor and operate the brake system

All the above proposed design models contributed to safety of vehicles and pedestrians. It prevented rear end crashes , provided ABS for sharp turns or slippery roads. But all these are applicable for vehicles running in conventional direction, so we need to develop systems which enhances the performance and safety of vehicles when it moves in reverse direction. A model designed on reversing of vehicles provided detection of obstacle , speed control mechanism based on binocular cameras. Thus, in this paper we propose "Automatic Reverse Braking system" to prevent collision by using sensors to detect obstacles. The "Automatic Reverse Braking system" is processing the sensor data and controlling the vehicle to prevent accidents.

#### *B. Review of Speed Control and Automatic Braking System Gopal P. Gawande, Shruti V. Gavhale , Irshad A. Zariye , Sagar P. Ritpurkar EXTC Department, AVBIT, Pavnar (WARDHA), Maharashtra (INDIA)*

The proposed work is likely to control the speed of vehicle and automatic format braking system. It is divided into three main steps; 1. Detect the object (Hurdle) from vehicle. 2. Control the speed of vehicle. 3. Automatic braking system. The proposed method will automatically inform about the hurdle in the path of the vehicle on the display with the help of different sensors. Ultrasonic sensors are connected in the vehicle to sense the object (Hurdle) and then send signals to the controller. The controller takes different actions based on these signals in order to create a safe environment for the driver. After detecting the obstacle in front of the car, we will directly view the distance between the car and obstacle on the LED display. When the distance between two cars or distance between cars & obstacle is very small, means if accidents like situation are detected by IR sensor then the automatic braking system is activated.

### IV. WORKING AND DESIGN

#### **A. Working**

The compressed air from cylinder as shown in Fig 6 is built by the pressure difference from the atmosphere. The air passes through the pneumatic pipes for storage in the reservoir.



Fig 6 Air compressor

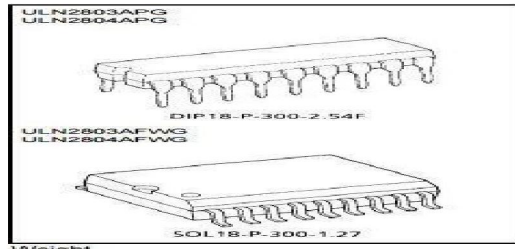

Fig 7 Driver

The compressed air passes through the pipes and reaches the reservoir as shown in Fig 7 and collect it there and is used for reserve purpose.



Fig 8 Air Storage tank



Fig 9 Buzzer

Nearly 10cms the air pushes the solenoid valve and hits the cylinder piston as shown in fig 8 and cylinder expands as shown in fig 9 and pushes the cam to apply brake so that the brake pads move towards the drum and the brake is applied.



Fig 10 Piston cylinder

If the circuit need not to be required during certain times of situation the hand lever directional valve is used to apply brake. The directional valve used has a lever to apply brake and to give way to passage of pressurized air.



Fig 11 Expand cylinder

The frame of this project as shown in fig 5.1.8 is build with ms pipe material of 1” tube and shafts are designed according to the bearing as shown fig5.1.9



Fig 5.1.8 Frame and shafts with tyres

And tyres are take as scooty tyres and gives the body a strong structure to with stand on it. The bolts and nuts as shown in fig 5.1.10 are used for fitting all accessories on the frame likewooden plank, bearing, tyres etc...



Fig 5.1.10 Fittings

The pneumatic pipes are loaded non leakage of air pipes as shown in fig 5.1.10. Cylinder and pipes are connected by T shape pipes. as shown in fig 5.1.11.



Fig 5.1.11 Valve fitting of pipes

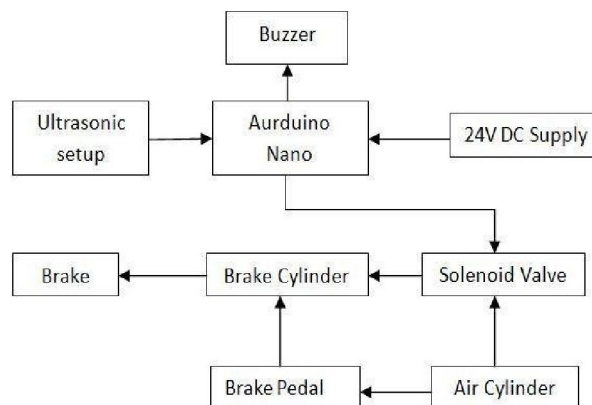

Fig 5.1.12 Actual working of Braking system

The above figure shows the actual working of “Automatic Braking System using Ultrasonic waves. Mechanical and electrical breaks both systems are placed in the unit, Whenever the electrical system fails then we can normally apply the brakes. So there is no problem with the failure of electrical braking. a buzzer indication will always indicated when the obstacle faced, so driver can easily hit the brake by using brakepedal.

**V. DESIGN AND CALCULATION**

The braking distance is the main factor considered in this system. Braking distance for a particular speed is the distance between the point of application of the brakes and the point at which the vehicle comes to a complete stop from the present speed. It is calculated by using following formula.

$$\text{Braking Distance} = \frac{V^2}{2\mu g} \text{ (meter)}$$

Where

V = Velocity of the vehicle (m/s)

$\mu$  = Coefficient of friction of road = 0.8

g = Acceleration due to gravity = 9.81(m/s<sup>2</sup>)

In this formula the condition of brakes and the road conditions are not considered for coefficient of friction  $\mu$ .

Table showing braking distance:

Velocity (km/hr)	Braking Distance (m)
60	17.69
50	12.28
40	7.86
30	4.42
05	0.12

Table 5.2.1 Velocity vs. Braking distances

**Fabrication**

Metal fabrication is the building of metal structures by cutting, bending, and assembling processes. It is a value added process that involves the construction of machines and structures from various raw materials. A workshop will bid on a job, usually based on the engineering drawings, and if awarded the contract will build the product. Large workshops will employ a multitude of value added processes in one plant or facility including welding, cutting, forming and machining.

**Raw materials**

Raw material used in the project is mild steel. for the frame of the vehicle and shaft to transmit the power to wheels equally for all the four wheels. and wood platform for the support of require components on the vehicle like air reservoir, electrical circuit, brake cylinders etc... Steel is an alloy of iron and other elements, primarily carbon, which is widely used in construction and other applications because of its high tensile strength and low cost. Steel's base metal is iron, which is able to take on two crystalline forms (allotropic forms), body centered cubic and face centered cubic (FCC), depending on its temperature.

**Mild steel**

Stainless steels generally contain between 10-20% chromium as the main alloying element and are valued for high corrosion resistance. The steel used to make the frame mild steel 1.5 inch rod for frame which has the shaft bright round bar for transmission of speed towards all respective wheels. Welding is done by using electrodes and join of the pipes through heating process



Fig 5.3.1 Frame of ms steel of 1.5 inch welded as a frame using arc welding



**Welding**

Welding is the main focus of steel fabrication. The formed and machined parts will be assembled and tack welded into place then re-checked for accuracy. A fixture may be used to locate parts for welding if multiple weldments have been ordered.



Fig 5.3.2 Frame with wooden plank

**Pedestal Bearing**

A pillow block, also known as a Plummer block or housed bearing unit, is a pedestal used to provide support for a rotating shaft with the help of compatible bearings & various accessories. A pillow block may contain a bearing with one of several types of rolling elements, including ball, cylindrical roller, spherical roller, tapered roller, or metallic or synthetic bushing. The type of rolling element defines the type of pillow block. These differ from "plumber blocks" which are bearing housings supplied without any bearings and are usually meant for higher load ratings and a separately installed bearing. Bearing used in this project are UCP205-16 P205.



Fig 5.3.4 1" Pedestal bearing

**Tyres**

Tyre is used to support the frame on its hub present on the wheel so that the body weight can equally distributed over all the surface after the load is applied on the frame. The friction cause tyre rotate on move the shaft in the hub which is hold by bearing to rotate freely on its own by transmission of power from engine through chain. Tyre used in this thesis is the wheeland diameter 9.5\*100.

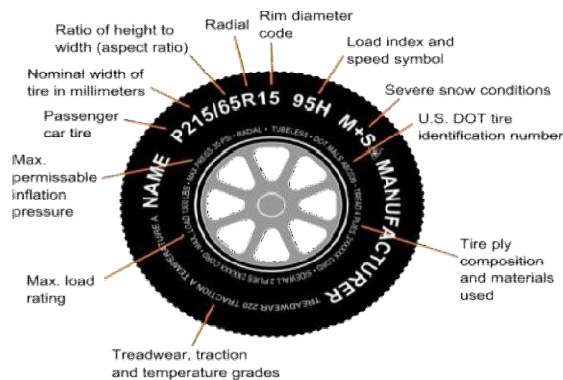

Fig 5.3.5 Specification of a wheel

## **VI. CONCLUSION**

The ULTRASONIC BRAKING SYSTEM, if executed in auto it deflects heaps of mishaps and can spare human lives and property. Execution of such a propelled framework can be made mandatory like wearing of safety belts with the goal that mischance's can be deflected to some degree. Our Infrared Braking System gives a look into the eventual fate of car wellbeing and the amount more propelled this individual framework can be for staying away from mischances and ensuring vehicle tenants when they are incorporated into one framework. The fate of car security is more than simply building up another innovation; it is moving the way to deal with wellbeing. ULTRASONIC BRAKING SYSTEM approach speaks to a huge movement from the conventional way to deal with well being, yet it is crucial to accomplishing the significant advantages.

## **REFERENCES**

- [1].Parande , Khade , Kolpe ,Gavande , “Intelligent Braking System by Using Microcontroller and Sensor”. International Journal of Advance Research in Engineering, Science & Technology e-ISSN: 2393-9877.
- [2].<http://blog.utp.edu.co/automatmecanica/files/2013/06/FRENOS-DE-AIRE.pdf>.
- [3].Westerveld, Wouter J (2014). Silicon photonic micro-ring resonators to sense strain and ultrasound (Ph.D.). Delft University of Technology. ISBN 9789462590793
- [4].<http://www.mouser.com/ds/2/595/Arduino-ArduinoBoard Nano-494191.pdf>.
- [5].Jian Chu1, Yan Feng. “automatic control process of solenoid valve base on Plc and touch screen.” INTERNATIONAL JOURNAL ON SMART SENSING AND INTELLIGENT SYSTEMS VOL. 6, NO. 5, DECEMBER2013