

# Dual-Axis Solar Tracking System

**Mr. Maheshwar Dnyaneshwar Chopade<sup>1</sup>, Mr. Vikas Vijay Sonune<sup>2</sup>, Mr. Prem Vijay Arakh<sup>3</sup>,  
Mr. Vinod Dilip Shelke<sup>4</sup>, Mr. Rushikesh Janardhan Sarkate<sup>5</sup>, Prof. K. K. Rajput<sup>6</sup>**

Research Scholar, Department of Electrical Engineering<sup>1,2,3,4</sup>

Research Scholar, Department of Electronics Telecommunication Engineering<sup>5</sup>

Assistant Professor, Department of Electrical Engineering<sup>6</sup>

P L Institute of Technology and Management Studies, Buldana, Maharashtra, India

**Abstract:** *In today's era, our life is dependent on energy. Nation's development is somehow associated with the availability of energy. Solar energy is the most eminent and renewable & cleanest sources of energy. It can be easily harnessed with the help of solar photovoltaic (PV) panels. But, we mainly observe that most of the solar panels are positioned at fixed angles. In order to maximize the amount of solar radiation collected by a solar panel, we use solar tracking device whose function is to follow the sun orthogonally throughout the day which enhances the energy capacity of the system. This paper comprises of development and design of dual axis solar panel tracking system & experimental study of dual axis solar tracker compared to fix position solar panel in terms of performance enhancement. The tracking mechanism of the sun requires light dependent resistor (LDR) as sensor to sense the maximum light availability & two DC motor for two axis movement (i.e., vertical and horizontal) to direct the position of solar panel. The software part is done by the help of written code using an Arduino Uno controller.*

**Keywords:** Solar.

## I. INTRODUCTION

In present scenario dependency on energy is increasing day by day, which leads to the increase in demand of energy resources mainly fossil fuels (coal, oil and gas). The crisis of energy and environmental degradation are main causes of increasing concern. Utilization of sustainable and renewable energy sources are key solutions of these problems (Sharma, D. K., & Purohit, G., 2014). Solar energy is an everlasting, clean and renewable source of energy without any potential damage to environment. The power received by the earth through the sun is about  $1.8 \times 10^{11}$  MW, which is thousand times larger than the current power consumption from all sources. Conversion of solar energy into electrical energy takes place by photovoltaic (PV) cells using photovoltaic effects. A PV module is a combination of interconnected assembly of PV cells. In order to gain maximum power output from PV panels, one needs to keep the panel in the most appropriate position. So that sun radiations are orthogonal to the panel during the day. So, it is essential to have a sun tracker attached to the PV panel (Quesada, G., Guillon, L., Rousse, D.R., Mehrtash, M., Dutil, Y. & Paradis, P.L., 2015). As compared to the fixed position PV panels, a mobile PV panel is better result oriented as it gains maximum solar energy (Khanduri, Naman, Arvind Kukreti, and Neeraj Shah, 2017). So many different approaches have been implemented so far in the designing of dual axis solar tracker. Generally, they are categorized as either open-loop tracking types or closed loop tracking types (Jing-Min Wang and Chia-Liang Lu, 2013). An open loop tracking approach is achieved by a tracking formula or control algorithm. The control algorithms are executed with the help of microprocessor controller. In closed-loop tracking approach, active sensor such as light dependent resistors (LDRs) are used as in (Çinar, S.M., Hocaoglu, F.O. and Orhun, M., 2014). This paper proposed a model of dual axis solar tracker with possible minimum complexities & more feasible in terms of cost and operation. It also provides the enhancement in the performance of energy harnessing through the PV panels by using solar tracker in compare to the fixed panels.

## II. SOLAR TRACKER

Solar tracking is a mechanism by which we can create a system to tilt the solar panel in the direction of movement of the sun. It is essential to perform sun tracking, in order to enhance the performance of the system. It can result in the collection

of more than 30% extra energy from the same collector (Tiwari, A., Vora, M., Shewate, P. and Waghmare, V., 2016). Solar tracking system approaches with higher accuracy can be achieved by Single Axis schemes and Dual Axis structure.

### 2.1 Single Axis Solar

Tracker Single Axis trackers have one axis of rotation. There are several possibilities for implementation of Single Axis solar trackers. Which include horizontal single axis trackers (HSAT), horizontal single axis tracker with tilted modules (HTSAT), vertical single axis trackers (VSAT), tilted single axis trackers (TSAT) and polar aligned single axis trackers (PSAT)? The tracking schemes are designed such that maximum beam of radiation over given period of time collected (Zhang, Yiyuan, Jiahao Zhao, Yajiang Yin, and Zheng You, 2017). The use of single axis solar tracker can increase the electricity output as much as 27% to 32% (Tiwari, A., Vora, M., Shewate, P. and Waghmare, V., 2016).

### 2.2 Dual Axis Solar Tracker

Dual Axis Solar trackers have two degree axis of rotation one is along vertical axis and another is along horizontal axis. It gives maximum solar exposure because of its ability to follow the sun, irrespective of sun position in the sky, dual axis trackers enable the PV panel to align itself in the direction of sun (Çinar, S.M., Hocoğlu, F.O. and Orhun, M., 2014). In dual axis solar tracker vertical axis follows the angular height position of the sun in the sky and horizontal axis follows the east to west movement of the sun. According to (Tiwari, A., Vora, M., Shewate, P. and Waghmare, V., 2016), dual axis tracking shows 35% to 40% increase in power output.

### 2.3 Component Used for Purposed Experimental Hardware Architecture

- LDR (Light Dependent Resistor) • LDR is the sensing element in the project, its resistance varies as the intensity of the light changes. It is positioned on each corner of the solar panel with a resistance in series with it. Each of the 2 LDR sends an analog input to the microcontroller which further control motors (Bhote, M.V. and Singh, J., 2014).
- Solar Panel • In this project a photovoltaic solar panel of rating 2 watt is used,  $V_{oc} = 12$ ,  $I_{sc} = 166.6\text{mA}$ , weight = 120g. This solar panel is made to rotate in two different directions viz (horizontal and vertical movement) by the two different DC motor motors of different ratings, the panel is controlled by the two DC motor motors, one DC motormotor is connected at base of the setup (for horizontal movement) and another is with the side arm support of the panel (for vertical movement).
- Microcontroller AT-mega 328 • Microcontroller is the heart of this project, as all the computations of the values of the LDR input followed by A/D conversion and generating actuating signals for the DC motor motors at right instant at each motor for the movement of the panel is solely done by this microcontroller. It is powered by 5V DC supply (Arduino Uno, 2018).
- DC motor •DC motor is a normal DC motor which is controlled by the help of DC motormechanism. DC motormechanism provides a closed loop feedback control system. The main objective of using a DC motor is to provides angular precision i.e., it will rotate as per the signal given to it. In this setup two DC motors are employed, each DC motor has a different a rating and placed according to their ratings.

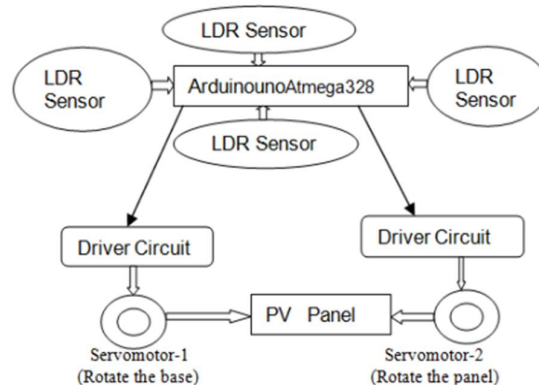

Fig. 1- Block Diagram of whole system realizes automatic dual tracking mechanism.

### 2.4 Designing of Overall System

The whole system is dependent on automatic tracking mechanism instead of a predefined motion. The sensors are the feedback constituents as they provide signals to the control system. Microcontroller plays an important role in controlling mechanism or control system. The aim of microcontroller is to determine the direction of motor rotation, according to the signal receives from the respective LDR. So, the whole system adjusts itself for the sunlight to fall directly on the panel.

### III. HARDWARE DESIGN SET UP

Implementation of dual axis solar tracker is simple but we have to must take care while designing it. Circuit comprises of 4 LDR and 4 resistors, connected in such a way that they act as a voltage divider and output is provided to analog input pins of arduino. Pin no. 9 and 10 of arduino are responsible for providing PWM inputs to the two DC motors. LDRs are used to sense the presence of light. The two DC motormotors are put on the structure in such a manner that one responsible for horizontal movement and another for vertical movement. Now the program is uploaded for arduino to the microcontroller. Project is working as follows. •Two LDR sense the presence of maximum sunlight, which are situated at four corner of PV panel. • For east to west tracking, if the analog values of top LDRs are more in compared to bottom two LDRs, then vertical DC motor will move in that particular direction • If the bottom LDRs receives more light, the DC motor moves in that particular direction. • For the angular deflection of the solar panel, if the left sets of LDRs receive more light than the right set, the horizontal DC motor will move in that particular direction. • If the right set of LDRs receives more light, the DC motor moves in that particular direction.

#### 3.1 Base DC motor and Side Arm

All the rotating mechanism of the project is lied on this structure, which serves two purposes, primarily it provides the rigidity and stability to the complete structure against the odds of the nature, such as high speed winds, secondly if makes the movement much more refine as these three support on base takes all the weight of the setup from the motor shaft and thus allow the motor to precisely deflects the setup.

#### 3.2 Complete Hardware

Finally, to make automatic dual axis movement solar tracker, we make proper connections of all the hardware, so that they work to track the sun. It was very important concern while designing the system because the slightest movement of sun could be tracked. The complete circuit used to track the sun is shown in figure 7. As the circuit shows we used 2 LDRs in order to track the sun on two axis. Each pair of LDRs is responsible for tracking the sun on each of the two adjacent LDRs are measured and that output is fed to four inputs in the microcontroller.

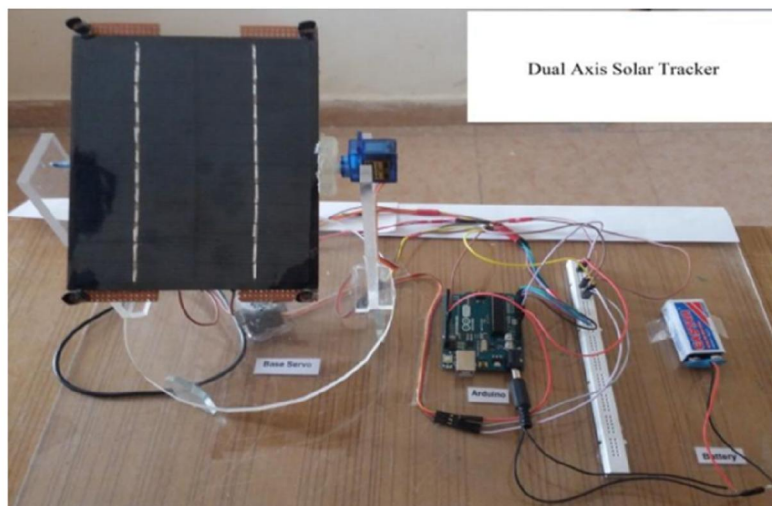

Fig.3 Final Purposed Hardware Setup to Find the Efficiency of Solar Panel.

#### **IV. CONCLUSION**

As we know the world is facing shortage of energy due to continuous depletion of non-renewable energy resources. As we have been using conventional sources of energy since ages. We are now planning to harness solar energy to bridge the gap between demand and supply in rural areas. The use of solar energy is free, does not create pollution, and if used widely it can help in reducing dependency on other costly and damaging sources of energy. This project emphasizes on harnessing the maximum amount of solar energy from the solar panel with the help of two-axis tracking mechanism through the microcontroller as compared to the static solar panel, the method of two-axis tracking increases the share of the solar power in the total power production from the non-conventional energy resources and thus tends to make our environment pollution free and thus development is sustainable.

#### **REFERENCES**

- [1]. Sharma, D. K., & Purohit, G. (2014). Improving the Liveability of Cities: The Role of Solar Energy in Urban and Peri-urban Areas. In *The Security of Water, Food, Energy and Liveability of Cities*, (pp. 151-162). Springer Netherlands,
- [2]. Quesada, G., Guillon, L., Rousse, D.R., Mehrtash, M., Dutil, Y. & Paradis, P.L., (2015). Tracking strategy for photovoltaic solar systems in high latitudes. *Energy Conversion and Management*, 103, pp.147-156.
- [3]. Khanduri, Naman, Arvind Kukreti, and Neeraj Shah. "Implementation of solar time based sun tracking systems for mobile platforms and smart cities." In *IEEE Region 10 Symposium (TENSymp)*, 2017, pp. 1-5. IEEE, 2017.
- [4]. Jing-Min Wang and Chia-Liang Lu, "Design and Implementation of a Sun Tracker with a Dual-Axis Single Motor for an Optical Sensor-Based Photovoltaic System" *Sensors* 2013, 13, 3157-3168; doi:10.3390/s130303157
- [5]. Çinar, S.M., Hocaoglu, F.O. and Orhun, M., 2014. A remotely accessible solar tracker system design. *Journal of Renewable and Sustainable Energy*, 6(3), p.033143.
- [6]. Tiwari, A., Vora, M., Shewate, P. and Waghmare, V., 2016. Sun Tracking Solar Panel with Maximum Power Point Tracking. *International Journal of Engineering Science*, 2451.