

Arduino-Based High-Temperature Furnace Monitoring and Controlling System

A. V. Bokare¹, Keshao D. Kalaskar², R. D. Wakodikar³

Research Scholar, Department of Computer Science, S. P. College, Chandrapur (M.S.), India¹

Ex-Professor, Department of Computer Science, Dr. Ambedkar College of Arts, Commerce & Science, Chandrapur²

Assistant Professor, Department of Electronics, N. H. College, Bramhapuri (M.S.), India³

Abstract: *Industrial furnaces require precise temperature monitoring and control to ensure efficiency, safety, and product quality. This paper presents an Arduino-based high-temperature furnace monitoring and control system designed to provide real-time temperature readings, automated control, and safety features. The system utilizes thermocouples to measure high temperatures, an Arduino microcontroller for processing data, and relay modules to regulate heating elements. In this system, the user sets the value of temperature, and if the temperature of the furnace exceeds the set limit, the furnace power supply is cut off, and if the temperature goes down the set value, power supply is re-established. The switching of AC power supply to the furnace is done with the help of a relay circuit. A liquid crystal display (LCD) is used to display the temperature reading and set value of temperature.*

Keywords: Arduino, LCD, Thermocouple, Temperature Sensor

I. INTRODUCTION

Temperature measurement system is an important aspect of most of the industrial operations, scientific experimental setup and laboratory setup, Since thermal monitoring guarantees both process efficiency and product quality [1].

With the rapid development of Science and Technology, the temperature monitoring system has been used in a variety range of industrial and research applications. Electric high-temperature furnaces are used in industrial, research purpose etc. Temperature management becomes essential in many instances of process automation. The temperature may be detected with several kinds of sensors, ranging from basic to advanced. A few well-known applications for temperature management are room temperature control and environmental monitoring. Temperature may now be recorded, monitored, and regulated more easily and programmable thanks to new technologies that support both hardware and software [2-5]. Microcontrollers have become so good at monitoring the temperature that they are now used as standards for modeling and testing certain temperature sensors for autonomous temperature monitoring. Several tasks may be accomplished on the correct hardware and software platform [5-10].

The electric furnace is widely used in various industries. There are various types and ranges of electric furnaces. An electrical furnace is a type of electrical appliance that produces heat from electricity. It is used to heat or melt the material which is placed inside the heating chamber in a controlled manner.

A thermocouple is a sensing device which is used to sense the temperature from another electrical device. Thermocouple is a high temperature sensor range from -200°C to +1800°C and it is widely used in industrial application because of high temperature requirement.

In this system, a thermocouple as a temperature sensor will be used and its output is applied to the microcontroller. A microcontroller-controlled signal is applied to the power-regulating circuit. A power-regulating circuit is used to regulate the electrical power of the furnace as per the desired level. A microcontroller is interfaced with the LCD display module which displays the temperature reading.



Block Diagram of System

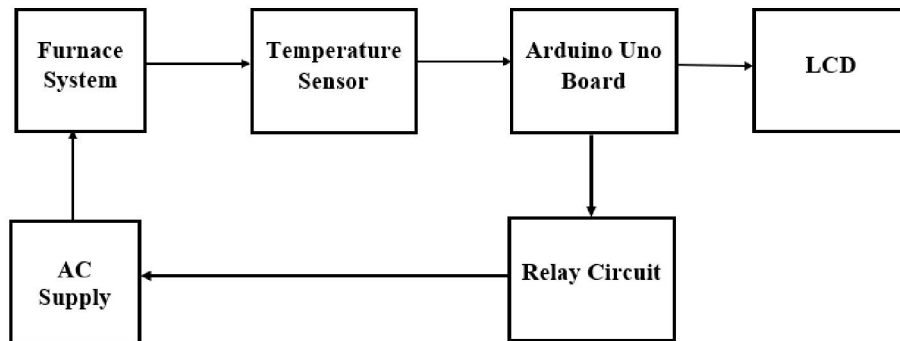

Figure 1. Block diagram of the System

As shown in the block diagram, there are four main blocks in which the furnace is the core component of the system. The function of the furnace is to generate heat that can be used to process the material. In order to operate the furnace, it requires an AC power supply. However, the material is to be heated in the furnace at a specific temperature, for which temperature measurement and monitoring are necessary. Therefore, the temperature sensor is installed in the furnace chamber, which senses the heat, and its output is applied to the microcontroller board. It processes the temperature reading and sends it to the display unit. The display unit displays the value of temperature that allows the operator to monitor the temperature value. There is a relay circuit used to cut off the power supply when the temperature of the furnace goes beyond the set limit.

Circuit diagram

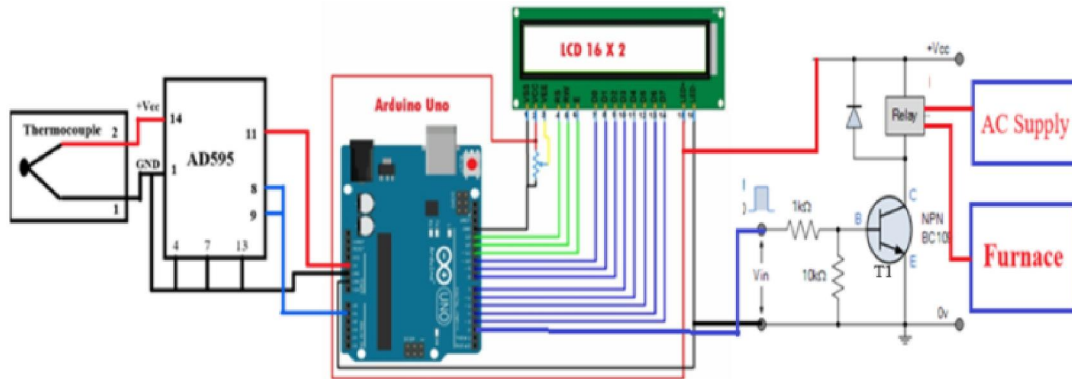

Figure 2. Interfacing Thermocouple with Arduino Uno and LCD

II. METHODOLOGY/ WORKING

A muffle furnace is operated on 230V AC and it is connected via a dimmer state. A K-type thermocouple as a temperature sensor is placed inside the chamber. The output of the thermocouple is connected to pins 14 and 1 of IC AD595.

The AD595 is a single-chip thermocouple reference junction and full instrumentation amplifier. It uses a frozen point reference and an amplifier that has already been calibrated to generate a top level (10 mV/°C) output straight generated by the thermocouple [11]. It can be used to amplify its compensation voltage directly, thereby converting it to a stand-alone Celsius transducer with a low impedance voltage output. Its compensation voltage may be directly amplified,



turning it into an isolated Celsius converter with a low resistance voltage output [12]. The output pins 8, 9 of AD 595 are connected to Arduino Uno board pin A1, as shown in figure (2). The program written for the Arduino Uno board that read, converted into analog to digital form and calibrated the data of AD595 and displayed it on 16X2 LCD module.

The digital pin 3 of the Arduino board is connected to the base of transistor T1, which changes the state of the relay. AC power is supplied to the furnace via relay. The function of the relay to cut off the AC supply when the temperature is exceeded to set a limit value. The temperature set value is entered through the serial monitor of Arduino IDE, and it is also displayed on the LCD module. If the temperature of the furnace goes beyond the set value, the digital pin 3 of the Arduino board becomes high and transistor T1 is conducted therefore, relay cut off the AC power supply of furnace to maintain the temperature of furnace. If the furnace temperature goes low than the temperature set value, the digital pin 3 of the Arduino becomes low, and the transistor goes into cutoff mode and power supply to furnace is reestablished. In this way, this system maintains the temperature at a constant level.

This system monitors and controls the high temperature of the furnace using Arduino. However, it measures an approximate value of the temperature. The system effectively monitored and displayed real-time temperature readings with an accuracy of $\pm 10^{\circ}\text{C}$, as compared to a standard temperature measurement meter. The Arduino Uno board successfully operated the relay circuit, which cut the power supply of the furnace when the temperature value exceeded the set value and maintained the stable temperature. However, there is little fluctuation in reading due to the electrical noise and external noise in the system. The significant advantage of this system is its automation, which eliminates the need for constant human supervision.

Experimental Setup Photos

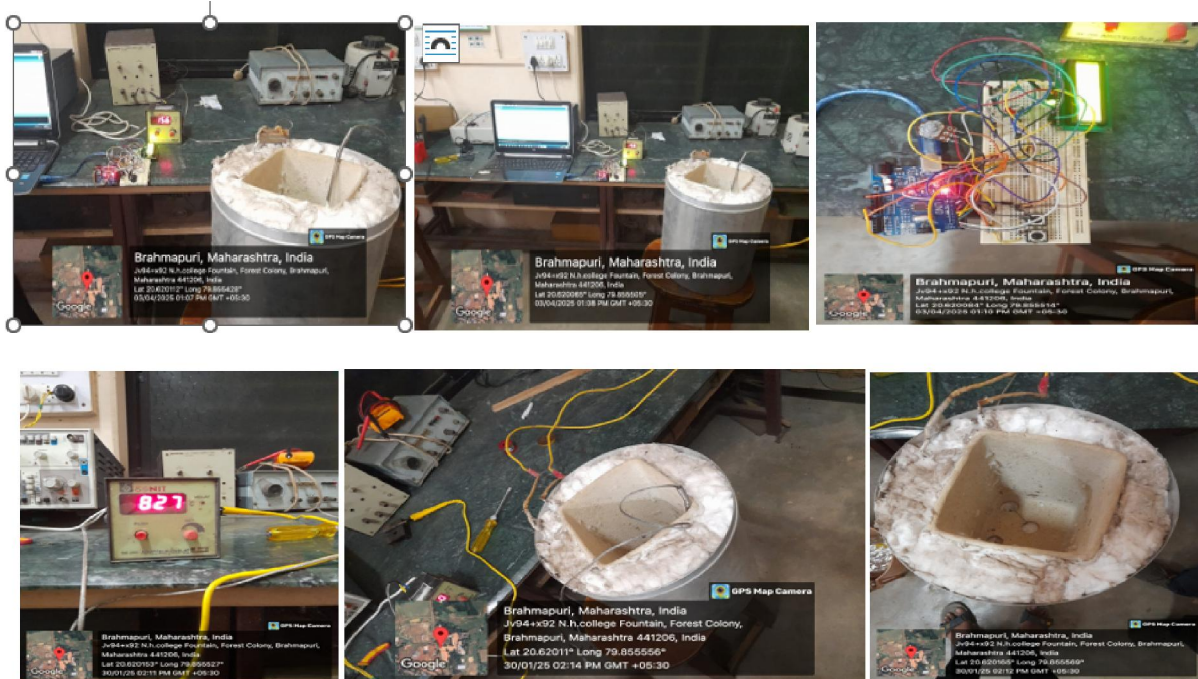

Figure 3. Experimental setup photos



Limitation

The system's accuracy, response time and stability are highly dependent on the quality of the temperature sensor used. The quality of the final product is determined by the material used; if the quality is low, the results will be poorer to those of high-quality materials.

High temperatures sometimes necessitate additional cooling systems, which raises the complexity and expense.

System components may experience mechanical breakdown as a result of repeated heating and cooling cycles.

In some settings, such as chemical factories, improper control can result in safety risks.

III. CONCLUSION AND FUTURE SCOPE

In conclusion, the Arduino-based high-temperature furnace monitoring and controlling system is probably used in most of the industries and laboratory which provides an efficient, cost-effective, and scalable solution for industrial and laboratory applications where the high-temperature is mandatory. With further refinements, this system has the potential to revolutionize temperature management in high-temperature environments.

In the future, the alarm system can be implemented to provide a crucial safety feature, preventing overheating and potential damage.

REFERENCES

- [1] A. V. Bokare, K. D. Kalaskar, and R. D. Wakodikar, "Study of Thermoelectric Characteristics of K-Type Thermocouple for Temperature Applications," *International Research Journal of Modernization in Engineering Technology & Science*, 2026, doi: 10.56726/irjmets91031.
- [2] A. Bayram, S. A. Moammed, and F. Kara, "Design of Heating System Controlled by Arduino," in *Proc. 4th Int. Symp. Innovative Technologies in Engineering and Science*, 2016, pp. 1583–1591.
- [3] R. Abdullah, Z. Ismael, N. N. S. N. Rizman, S. I. Dzulkefli, R. Ismail, S. Shafie, and M. H. Jusoh, "Design an Automatic Temperature Control System for Smart Tudung Saji Using Arduino Microcontroller," *ARPN Journal of Engineering and Applied Sciences*, vol. 11, no. 16, pp. 9578–9581, 2016.
- [4] W. Widhiada, D. N. K. P. Negara, and P. A. Suryawan, "Temperature Distribution Control for Baby Incubator System Using Arduino ATmega 2560," presented at Bali, Indonesia, 2017, pp. 1748–1751.
- [5] N. Dangi, "Monitoring Environmental Parameters: Humidity and Temperature Using Arduino-Based Microcontroller and Sensors," 2017.
- [6] K. Kesarwani, S. M. Pranav, T. N. Noah, and K. V. N. Kavitha, "Design of Temperature-Based Speed Control System Using Arduino Microcontroller," vol. 14, no. S3, pp. 753–760, 2016.
- [7] V. Bhatia and G. Bhatia, "Room Temperature Based Fan Speed Control System Using Pulse Width Modulation Technique," *International Journal of Computer Applications*, vol. 81, no. 5, pp. 35–40, 2013.
- [8] T. Wellem and B. Setiawan, "A Microcontroller-Based Room Temperature Monitoring System," *International Journal of Computer Applications*, vol. 53, no. 1, pp. 7–10, 2012.
- [9] K. Nandagiri and J. R. Mettu, "Implementation of Weather Monitoring System," *International Journal of Pure and Applied Mathematics*, vol. 118, no. 16, pp. 477–494, 2018.
- [10] P. Singhala, D. N. Shah, and B. Patel, "Temperature Control Using Fuzzy Logic," *International Journal of Instrumentation and Control Systems (IJICS)*, 2014.
- [11] "AD595AQ Thermocouple Amplifier," Rhydolabz. [Online]. Available: <https://www.rhydolabz.com/ad595aq-thermocouple-amplifiers-pdip-14>. [Accessed: Jun. 2, 2026].
- [12] Analog Devices, "AD594/AD595 Monolithic Thermocouple Amplifiers with Cold Junction Compensation," Datasheet. [Online]. Available: https://www.analog.com/media/en/technical-documentation/datasheets/AD594_595.pdf. [Accessed: Jun. 2, 2026].

