

Modeling and Performance Evaluation of FACTS Devices Based on Water Level Controller with Time

Vimlesh Kumar Bharadwaj¹, Shaif Umer², Shubham Gupta³, Ajay Gupta⁴

B.Tech Students, Department of Electrical Engineering^{1,2,3}

Assistant Professor, Department of Electrical Engineering⁴

R. R. Institute of Modern Technology, Lucknow

Abstract: *This is an Arduino base Automatic water Level Controller and indicator project .Here, we are going to measure the water level by using help of ultrasonic sensors.*

The ultrasonic sensors use the principle of “echo”. When sound wave are transmitted, they after striking and obstacle return So, by using this principle we can calculate the time of travel for outgoing as well as returning. By calculation we can calculate the distance.

Here we use this concept in our project. The motor pump automatically turn ON when the water level is low. Actually, there is a lot of drinking water crisis in India and also in other countries today we need to preserve water at any cost .in India , we can see many house head overhead tanks and they keep un over flowaving water .

It wastes a lot of water as well as electricity .We do not do anything on this matter than we can face huge scarcity of water. In this project I Am going to implement automatic water level controller to that we not longer have to manually switch ON and OFF the motor.

Keywords: *Automatic water Level Controller*

I. INTRODUCTION

Water is the most important substance for the survival of living being. It is the most important factor of our life .Therefor, conservation of water should be the outmost primary of living beings as there is only 1% fresh water available in liquid form,2%is frozen state and rest of the 97% water is saline. Conservation of water include rain water harvesting ,protecting ground water, and practicing sustainable method of utilize water resources and educating the people through water programs.

An Arduino is a development board which consist of microcontroller. It is an open source development board which is designed to build prototype. In our project we have use Arduino to build “Water Level Controller” which serve the purpose of conservation of water. This circuit can be installed on water tank and problem of water overflow can be eliminated.

This circuit measure height of water in the tank and turn OFF the pumping system when water reaches a certain level. This not only save water but also save electrical energy at the same time. Hence the ground water can be conserved. This device chep, affordable and easy to install. It is fully automated i.e., once install can operation its own.

OBJECTIVE

An automated water level controller is a sensible technique to monitor and regulate the water level in the tank. It is a must have item in today’s household. Apart from the obvious benefit of the conserving water and using it wisely, there are a number of other noteworthy advantages of putting a smart water controller in your household.



Functions Automatically:

We are accustomed to manually checking the water levels. Constantly looking in the water tank in order to turn OFF the motor after the tank is full can be aggravating and laborious. The difficulty is entirely eliminated with a water controller because the procedure is fully automated. The motor will turn ON/OFF on its own once the water level in the tank reaches the desired level, thanks to timer switches.

Conserves Energy:

Water level controller that automatically adjust the water level save energy. They do it by automatically turning OFF the motor when the tank is full and when there is no water flow to the tank. This is especially useful in today's world when energy conservation is a top priority.

Saves Money:

Water level controllers help conserve energy and eventually help to save money. With the use of these technologies, water is managed, which means that wasted water and electricity and kept to a minimum.

System Design and Implementation

The following requirements are considered for the proposed Automatic water level controller.

- It is necessary to have ultrasonic sensors by using this sensor we gets distance from the sensor to water surface after it we need to calculate water level.
- In addition, the Arduino should be capable of connection to the sensor.

Block diagram of water level controller:

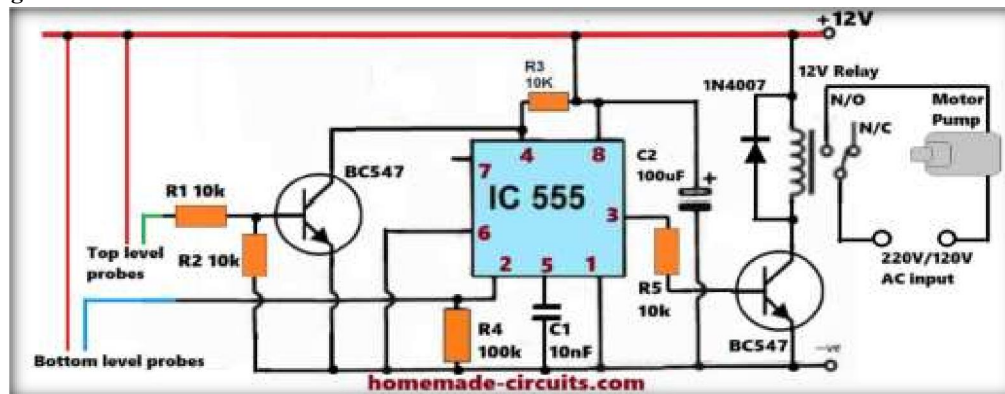

Fig.1: Block Diagram

Details:

- In this project only few components are used. Ultrasonic sensor of each lanes are interfaced to the Arduino. These sensor send the information to the Arduino board.
- An AC power supply is connected to run Arduino as well as sensors .
- Relays and some other connections are interfaced to the Arduino and relay is connected to the motor.
- The flow of progress continues from left to right in the above block diagram.



Project Model:

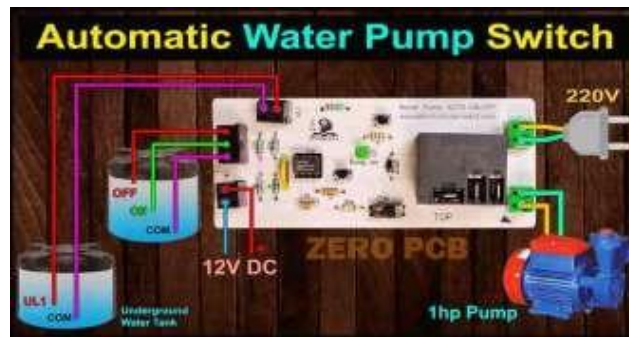

Fig.2

II. HARDWARE DISCRIPTION

1) ARDUINO UNO

The Arduino UnoR3 is a development board based on the AT mega 328. It has 14 digital input/output pins, 6 analog inputs, a 16 MHz ceramic resonator, a USB connection, a power jack, an ICSP header, and reset button. It contains everything needed to support the microcontroller, simply connect it to a computer with a USB cable or power it with an AC to DC adapter or battery to get started. The Arduino UNO can be powered via a USB connection or with an external power supply. The power source is selected automatically. External (non-USB) power can come either from an AC to DC adapter (wall-wart) or a battery. The board can operate on the external supply of 6 to 20 volts. If supply is less than 7V, however, the 5V pin may supply less than 5V and the board may be unstable.



Fig.3:

2) ULTRASONIC SENSOR:

Ultrasonic sensors are available for the past many decades and these devices continue to hold huge space in the sensing market because of their specification, affordability, and flexibility. As the automation industry has been progressing, the employment of ultrasonic sensors in multiple domains such as drones, EV vehicles is emerging.

- Ultrasonic measurement of distance, depth and thickness.
- Ultrasonic testing.
- Ultrasonic imaging.
- Ultrasonic machining, such as polishing, drilling.



- Ultrasonic cleaning.
- Ultrasonic welding.



Fig 4: Ultra Sonic Sensor

3) RELAY

In order to isolate two circuit electrically and to connect them magnetically relays are used. They are very useful in switching from one circuit to another when they are completely separated. The relays comprise of an input and an output section. The input section has a coil which produces magnetic field when a small voltage from a electrical circuit is applied. This applied voltage is known as the operating voltage.



Fig. 5: Realy

4) MOTOR:

A 12 volt DC motor is a type of electric motor that run on 12- volt direct current (DC) power. These motor are often used in a variety of application, such as automotive system , robotics, and portable tools and equipment. They are popular due to their versatility, efficiency ,and low cost.

III. WORKING

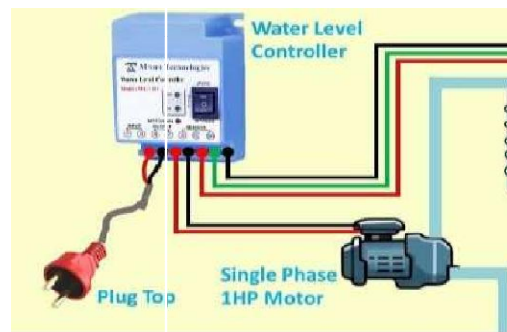

Fig.6:



Automatic water level controller working principle- 3 Types

Water is gift from gods and it should not be wasted. In most houses, we have water tanks that are filled for regular and daily use for water. Will switch the water motor on and keep track of the 30 to 90 minutes for the tank to fill up. Some time the water will fill the tank too fast or too slow, depending on the amount of water remaining in the tank. The rest of the storage tank water will be wasted.

There are a lot of control your water levels, Here we discover the working principle of 3 different type of water level controllers.

Ultrasonic Level Sensor Working Principle:

This water level controller will use two components the ultrasonic sensor and relay board. The distance of the motor to turn off and on needs to be specified. There is a special program that executes the sensor. There are a lot of capacitor, circuit board, resistor, and semiconductor used.

Circuit Diagram:

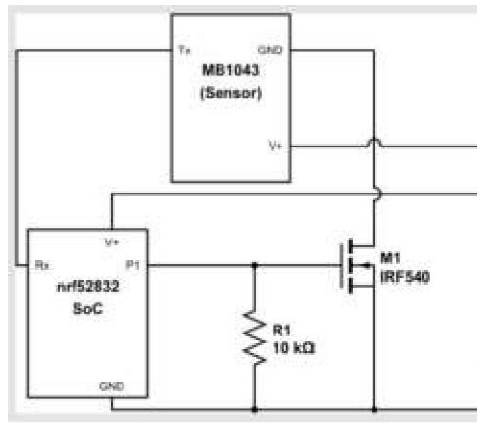

Fig.7:

An Arduino-based water level controller using an ultrasonic sensor can be used to automatically control the level of water in a tank.

The ultrasonic sensor is used to measure the distance from the top of the tank to the water level and this information is used to control a relay and the relay used to turn off the power when the water level reaches a certain point.

IV. RESULT

When the power is turned on an AC current of 230 volt is sent to a step-down transformer which converts it into a 12 volt AC current. This AC current is then converted into a DC current using voltage regulators.

The ultrasonic sensor sends a delay to an Arduino which calculates the distance to the water surface and determines if the water level is low or sufficient.

Advantages:

- Automatic water level controller can maintain an exact present water level.
- It can be installed in homes, hotels, and hospitals.
- The power used by this controller is low and negligible.
- It can be installed in metro cities where drinking water is the only water used for all purposes.
- Minimum maintenance.
- Automatic operation saves the manual labor cost and time.



Disadvantage:

- Water level sensor need to be replaced every 3 year.
- We need to insert the wire in accordance with the level of water.
- The rust, foul and deteriorate.
- Electronics are usually separately.

Applications:

- 1) Residential water tanks: Automatic water level controllers are used in home water tanks to ensure that water is filled without overflowing. This prevents wastage and ensures a steady water supply.
- 2) Industrial water management: In industries these controller are used in water storage tank, cooling system, and boilers to monitor and control water level, ensuring efficient operation of processes with manual intervention.
- 3) Agriculture irrigation system: They are used to control water level in irrigation ponds and reservoirs, providing a continuous water supply for crops while preventing overflows or running out of water.

V. FUTURE SCOPE

Automatic water level monitoring system has a good scope in future especially for agriculture sector. There are many areas where we need water level controller. It could be agricultural fields. Overhead tanks. We can make this project wireless by using NRF transmitter and receiver.

We can also add ethernet shield so that we can get the all information using mobile phones and control it accordingly. The automatic water level controller using Arduino project can also be installed with pH sensors which will help to regulate the acidity.

VI. CONCLUSION

An automatic water level controller provided a highly efficient and convenient way to manage water level in tank or reservoirs by automatically adjusting water pump operation. Significantly reducing water wastage, conserving and industrial application, making it a valuable tool for managing water resources effectively while minimizing manual intervention, essentially, it helps maintain optimal water level while preventing unnecessary pumping and water waste.

REFERENCES

- [1]. Kulkarni H. et al, "Examining the Thyristor-controller Reactor's (TCR) Performance to the minimize Self-generated Harmonics" J, Electrical System, 2024.
- [2]. Maiti D, et al, "Harmonic Cancellation in a Three Phase Thyristor Controlled Reactor Using Dual Bank," IEEE Trans. Smart Grid, 2016.
- [3]. Patil S. et al., "Performance Enhancement of Modified SVC as a Thyristor Binary Switched Capacitor and Reactor Bank by using Different Adaptive Controller," J. King Saud Univ. Eng. Sci., 2021
- [4]. "Electronic device and Circuit", By Robert L. Boylestad. Strong Basic of, Transistors Ics Relay Circuits.
- [5]. "Linear Integrated Circuits" -By D. Roy Choudhary Details Circuits explanation of 555 Timer Working.
- [6]. Some topics and figure are taken from with the help of AI Platform and Social Media.

