

# Design and Performance Analysis of an Automatic Emergency Braking System Using Ultrasonic Sensor and Arduino

Kundan<sup>1</sup>, Anurag Yadav<sup>2</sup>, Satyam Yadav<sup>3</sup>, Arun Kumar Yadav<sup>4</sup>, Abhishek Kumar<sup>5</sup>, Upendra Yadav<sup>6</sup>

<sup>123</sup> Student, Department of Mechanical Engineering

<sup>456</sup> Assistant Professor, Department of Mechanical Engineering  
Prasad Institute of Technology, Jaunpur, (UP), India

**Abstract:** Road accidents caused by delayed driver response and poor visibility remain a major challenge in modern transportation systems. This work presents the development and analysis of a low-cost Automatic Emergency Braking (AEB) system using an ultrasonic sensor and an Arduino-based controller for obstacle detection and collision prevention. The proposed system continuously monitors the distance between the vehicle and nearby obstacles using ultrasonic sensing technology. When an object is detected within a critical range, the controller automatically activates the braking mechanism without driver intervention. A prototype model was fabricated and tested under different operating conditions to study sensor response, stopping time, and braking performance. Experimental observations show that the system can successfully detect obstacles and initiate braking action within a short response time, thereby reducing the possibility of collision. The use of ultrasonic sensors provides reliable short-range detection with simple implementation and low power consumption. The developed system demonstrates an economical and efficient approach for improving vehicle safety and minimizing accidents caused by human error. The proposed model can further be enhanced for real-time automotive safety applications and advanced driver assistance systems.

**Keywords:** Automatic Emergency Braking, Arduino Controller, Ultrasonic Sensor, Collision Prevention, Vehicle Safety, Obstacle Detection

## I. INTRODUCTION

The continuous increase in the number of automobiles on roads has significantly raised the probability of traffic accidents and road-related injuries. A major percentage of these accidents occur because of human errors such as distracted driving, delayed reaction time, fatigue, and improper braking control. As vehicle speed and traffic density continue to increase, ensuring road safety has become an important challenge for the automobile industry. Therefore, advanced safety technologies are being developed to reduce accident rates and improve driver assistance systems.

Automatic Emergency Braking (AEB) is an advanced active safety system designed to reduce the possibility of collisions by automatically applying the brakes when an obstacle is detected in front of the vehicle. The system continuously monitors the surrounding environment and reacts faster than human response in emergency situations. AEB systems are capable of minimizing stopping distance and reducing collision severity, thereby improving passenger and vehicle safety.

Modern automatic braking systems utilize different sensing technologies such as radar sensors, cameras, infrared sensors, and ultrasonic sensors. Among these technologies, ultrasonic sensors are widely preferred for short-range applications because of their low cost, fast response, compact size, and reliable obstacle detection capability. These sensors operate on the principle of ultrasonic wave reflection, where high-frequency sound waves are transmitted toward an object and the reflected signals are analyzed to calculate distance.



In the present work, a prototype Automatic Emergency Braking system has been designed using an ultrasonic sensor, Arduino controller, relay circuit, and DC motor arrangement. The ultrasonic sensor continuously measures the distance between the vehicle and obstacles placed ahead of it. When the detected distance becomes smaller than a predefined safety limit, the Arduino controller automatically activates the braking mechanism through the relay system. This reduces dependency on driver reaction and improves braking response during emergency conditions. The proposed system aims to provide a simple, economical, and efficient safety solution for light motor vehicles. Experimental testing was conducted to evaluate obstacle detection capability, stopping response, and braking performance under different operating conditions. The developed model demonstrates effective automatic braking operation and highlights the potential application of low-cost intelligent safety systems in future automobiles.

## II. LITERATURE REVIEW

Several researchers have contributed to the development of intelligent braking and collision avoidance systems for improving automobile safety. Various sensing technologies and control methods have been investigated to reduce accidents caused by human error and delayed braking response.

Chirantana and Kanth (2015) studied a collision warning system integrated with automatic braking for electric vehicles. Their work emphasized the importance of driver assistance systems in reducing rear-end collisions caused by driver distraction and delayed reaction. The study highlighted the growing role of intelligent safety systems in modern automobiles. Bose et al. (2013) developed an automatic braking system assisted by image and video processing techniques for pedestrian and vehicle detection. The proposed system used vision-based algorithms for obstacle identification and automatic brake activation under poor visibility conditions. Their findings demonstrated improved reliability in accident prevention systems. Gavrilă (2000) proposed a pedestrian detection system for moving vehicles using contour-based object detection techniques. The study introduced a hierarchical template matching method for identifying pedestrians in urban traffic conditions and contributed significantly to the development of advanced driver assistance technologies.

Coelingh et al. (2007) discussed the practical implementation of collision warning systems with automatic brake assistance. The research focused on radar- and camera-based technologies for detecting potential obstacles and reducing collision severity. Their study showed that automatic braking systems can significantly improve road safety.

Brännström et al. (2009) investigated collision avoidance strategies using steering and braking assistance systems. The proposed model estimated possible collision scenarios and automatically initiated braking operations to avoid accidents. Simulation results demonstrated the effectiveness of autonomous braking systems under different traffic situations. Eidehall et al. (2010) presented an advanced Automatic Emergency Braking (AEB) system capable of detecting vehicles and pedestrians. The study emphasized the integration of collision warning, obstacle detection, and automatic brake actuation for improving vehicle safety. Likun Xia et al. (2013) reviewed the development trends and technological advancements in automated emergency braking systems. Their work highlighted important performance parameters such as stopping distance, response time, and collision reduction capability. The study also emphasized the need for cost-effective safety systems suitable for modern vehicles. Hrishikesh Shivankar et al. (2017) proposed an intelligent braking system using infrared sensors for obstacle detection. The developed system automatically applied brakes when objects were detected within a predefined distance. Their findings indicated that sensor-based automatic braking systems can effectively reduce driver dependency. J. V. Sai Ram (2018) developed an ultrasonic sensor-based automatic braking mechanism controlled by an Arduino microcontroller. The system detected nearby obstacles and activated warning signals and braking operations automatically. Experimental results showed reliable obstacle detection and quick braking response.

Previous studies indicate that automatic braking systems have considerable potential in improving road safety and reducing collision risks. However, many existing systems involve complex and expensive sensing technologies. Therefore, there remains a need for a simple, low-cost, and efficient Automatic Emergency Braking system suitable for



light motor vehicles. The present work focuses on developing such a system using an ultrasonic sensor and Arduino controller for practical safety applications.

### **III. RESEARCH GAP**

Although significant advancements have been made in the development of Automatic Emergency Braking (AEB) systems, several limitations still exist in currently available technologies. Most commercial braking systems are integrated mainly in high-end vehicles and involve expensive sensors such as radar, LiDAR, and camera-based vision systems, which increase the overall cost of the vehicle. Many existing systems also require complex image-processing algorithms and advanced computational hardware for obstacle detection and decision-making. These systems may become less effective under poor weather conditions such as fog, dust, rain, or low visibility environments. In addition, the implementation of advanced braking technologies in low-cost and light motor vehicles remains limited.

Another major challenge is reducing driver dependency during emergency situations. Human reaction time plays a significant role in accident occurrence, especially during sudden obstacle appearance or distracted driving conditions. Conventional braking systems rely completely on manual driver response, which may not always be fast enough to avoid collisions. Therefore, there is a need for a simple, economical, and reliable Automatic Emergency Braking system capable of providing fast obstacle detection and automatic brake activation with minimum hardware complexity. The present work aims to address this gap by developing a low-cost ultrasonic sensor-based braking system using an Arduino controller for collision prevention and improved vehicle safety.

### **IV. OBJECTIVES**

The primary objective of the present work is to develop a low-cost and efficient Automatic Emergency Braking (AEB) system capable of reducing road accidents caused by delayed driver response and human error. The system is designed to detect nearby obstacles and automatically activate the braking mechanism without driver intervention.

The specific objectives of the project are as follows:

- To design and develop an Automatic Emergency Braking system using an ultrasonic sensor and Arduino controller.
- To detect obstacles placed in front of the vehicle using ultrasonic sensing technology.
- To automatically activate the braking mechanism when the obstacle distance becomes less than the predefined safety limit.
- To reduce stopping time and improve braking response compared to manual braking systems.
- To minimize the possibility of vehicle collision under emergency conditions.
- To study the performance of the developed prototype under different operating conditions.
- To provide a simple, reliable, and economical safety system suitable for light motor vehicles.
- To improve overall vehicle safety and reduce accident rates caused by human error and delayed reaction time.

### **V. SYSTEM DESIGN AND METHODOLOGY**

The proposed Automatic Emergency Braking (AEB) system is designed to detect obstacles in front of the vehicle and automatically apply braking action when the obstacle distance becomes critically low. The system mainly consists of an ultrasonic sensor, Arduino UNO controller, relay module, DC motor, battery supply, and braking mechanism. The overall architecture of the automatic braking system is shown in Fig. 1.



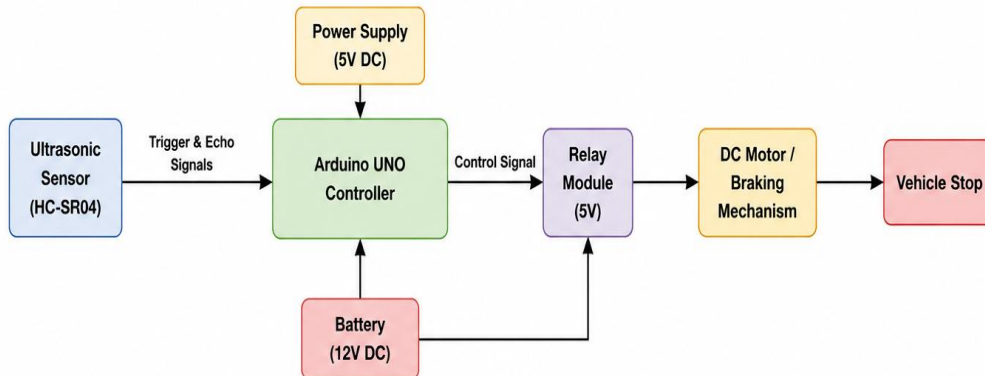

Fig 1: Block Diagram of Automatic Emergency Braking System

**A. Working Principle**

The system operates on the principle of obstacle detection using ultrasonic sound waves. The ultrasonic sensor continuously transmits high-frequency ultrasonic signals toward the front side of the vehicle. When these sound waves strike an obstacle, they are reflected back toward the sensor receiver. The time taken for the reflected waves to return is measured by the Arduino controller, which calculates the distance between the vehicle and the obstacle.

If the detected distance is greater than the predefined safety limit, the vehicle continues normal operation. However, when the obstacle enters the critical braking zone, the Arduino controller activates the relay circuit, which immediately stops the DC motor and initiates braking action. This automatic operation reduces human reaction delay and minimizes collision risk. The braking operation process is illustrated in Fig. 2.

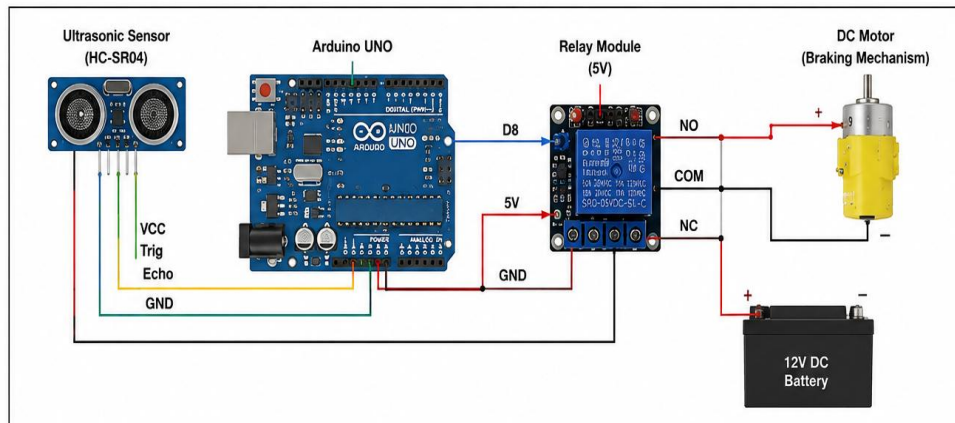

Fig 2: Circuit Diagram of Automatic Emergency Braking System

**B. Major Components**

The major components used in the developed system are:

- Ultrasonic Sensor
- Arduino UNO
- Relay Module
- DC Motor
- Battery



- Wheels and Chassis
- Jumper Wires
- Switch and Power Supply

### **C. Ultrasonic Sensor Operation**

The ultrasonic sensor functions based on the time-of-flight principle. The transmitter section emits ultrasonic waves, while the receiver section detects the reflected signals from nearby objects. The distance is calculated using the relation:

$$Distance = \frac{Speed\ of\ Sound \times Time}{2}$$

Where:

- Speed of sound = 343 m/s
- Time = Time taken for wave reflection

The ultrasonic sensor provides fast and accurate short-range obstacle detection, making it suitable for automatic braking applications.

### **D. Arduino Control System**

Arduino UNO acts as the central processing unit of the system. It receives input signals from the ultrasonic sensor, processes the distance information, and controls the braking mechanism through a relay module. The controller continuously monitors obstacle distance and executes braking commands automatically whenever necessary.

### **E. Experimental Procedure**

The prototype model was tested under different operating conditions to evaluate braking performance and sensor response characteristics. Obstacles were placed at different distances in front of the vehicle, and corresponding stopping time and stopping distance were recorded.

The experimental procedure involved:

- Detecting obstacles using the ultrasonic sensor
- Measuring sensor response time
- Recording stopping distance
- Observing braking performance under different speeds
- Evaluating system reliability and response accuracy

The collected observations were analyzed to determine the effectiveness of the developed Automatic Emergency Braking system.

## **VI. RESULTS AND DISCUSSION**

### **A. Experimental Results**

The developed Automatic Emergency Braking prototype was experimentally tested to evaluate obstacle detection capability, stopping time, and stopping distance under different operating conditions. During testing, obstacles were placed at predefined distances in front of the vehicle model, and the corresponding braking response was observed. The ultrasonic sensor successfully detected nearby obstacles and transmitted distance information to the Arduino controller. When the obstacle entered the predefined safety zone, the controller activated the relay system and automatically stopped the motor. The braking action was achieved with minimal delay, demonstrating effective collision avoidance capability.

The observed experimental results are presented in Table I.



Table I: Observation Recorded for Speed, Stopping Time and Stopping Distance

Speed (km/h)	Stopping Time (s)	Stopping Distance (cm)
0	0	0
1	2	10
2	4	15

### B. Performance Analysis

The obtained results indicate that stopping time and stopping distance increase with vehicle speed. At lower speeds, the developed system demonstrated rapid braking response and shorter stopping distance. The ultrasonic sensor provided reliable obstacle detection and continuous monitoring during operation. The automatic braking mechanism significantly reduced the dependency on driver reaction time. Compared to conventional manual braking systems, the developed model responded more quickly because the braking operation was automatically controlled by the sensor-controller arrangement. The experimental analysis also indicates that:

- The ultrasonic sensor provides accurate short-range obstacle detection.
- The Arduino controller processes signals rapidly with minimal response delay.
- The system effectively prevents collision under low-speed operating conditions.
- Automatic braking improves overall vehicle safety and braking reliability.

Table II: Sensor Response at Different Distances

Obstacle Distance (cm)	Sensor Detection	Brake Activation
50	Yes	No
30	Yes	No
20	Yes	Yes
10	Yes	Yes

The experimental observations indicate that the ultrasonic sensor provides reliable obstacle detection within the predefined sensing range. Automatic brake activation occurs when the obstacle distance falls below the critical safety limit.

Table III: Comparison of Manual and Automatic Braking

Parameter	Manual Braking	Automatic Braking
Reaction Time	Higher	Lower
Collision Risk	Moderate	Reduced
Driver Dependency	High	Low
Response Accuracy	Variable	Consistent

The comparison clearly shows that the proposed automatic braking system provides faster response and improved braking reliability compared to conventional manual braking operation.



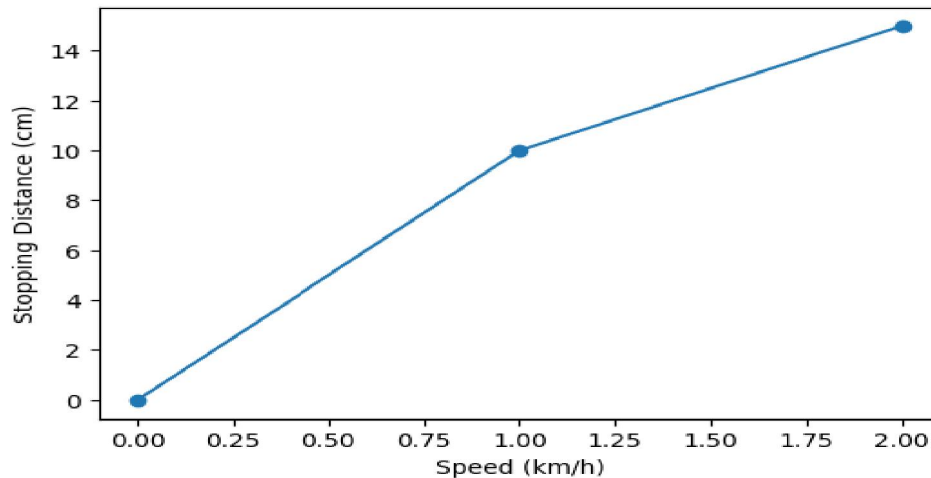

Fig 1: Speed vs Stopping Distance

The graphical representation indicates that stopping distance increases with vehicle speed. The proposed Automatic Emergency Braking system demonstrates effective braking response and reduces collision risk through rapid obstacle detection and automatic brake activation.

### C. Discussion

The developed Automatic Emergency Braking system provides a simple and economical solution for improving vehicle safety. The prototype demonstrated stable performance under different testing conditions and successfully reduced stopping delay caused by human reaction time.

However, certain limitations were also observed during experimentation. Environmental factors such as dust, moisture, and irregular obstacle surfaces may affect ultrasonic sensing accuracy. Additionally, braking performance may vary under high-speed conditions due to increased stopping distance requirements. Despite these limitations, the proposed system demonstrates considerable potential for practical automotive safety applications. The integration of low-cost sensors and microcontroller-based control makes the system suitable for implementation in light motor vehicles and educational prototype models.

## VI. CONCLUSION

The present work successfully demonstrates the design and performance analysis of an Automatic Emergency Braking (AEB) system using an ultrasonic sensor and Arduino controller. The developed system effectively detects obstacles placed in front of the vehicle and automatically activates the braking mechanism when the obstacle enters the predefined safety range. The prototype model exhibited reliable obstacle detection capability and rapid braking response during experimental testing. The experimental observations indicate that the proposed system reduces stopping delay and minimizes collision risk by decreasing dependency on driver reaction time. The ultrasonic sensor provided accurate short-range obstacle detection, while the Arduino controller ensured fast signal processing and brake actuation. The system demonstrated stable operation under different testing conditions and proved effective for low-speed collision avoidance applications.

Compared to conventional manual braking systems, the developed Automatic Emergency Braking system offers improved safety, reduced response time, and better operational reliability. The proposed model is economical, compact, and suitable for implementation in light motor vehicles and educational prototype applications. Although certain environmental conditions may influence sensor accuracy, the developed system demonstrates considerable potential for future automotive safety applications. Further improvements can be achieved by integrating advanced sensors, artificial



intelligence techniques, and real-time monitoring systems for enhanced vehicle safety and autonomous driving applications.

### VII. ACKNOWLEDGEMENT

The authors express their sincere gratitude to the Department of Mechanical Engineering, Prasad Institute of Technology, Jaunpur, for providing the necessary facilities and technical support to carry out this work successfully. The authors would also like to thank the project guide and faculty members for their valuable guidance, continuous encouragement, and constructive suggestions throughout the development of this project. Their support and motivation played an important role in the successful completion of this study.

Special appreciation is extended to all laboratory staff members and colleagues for their cooperation during fabrication, testing, and experimental analysis of the prototype model.

### REFERENCES

- [1]. Schram, R., Williams, A., & van Ratingen, M., "Implementation of Autonomous Emergency Braking (AEB), the Next Step in Euro NCAP Safety Assessment," ESV Conference, Seoul, 2013.
- [2]. Xia, L., Chung, T. D., & Kassim, K. A. B. A., "A Review of Automated Emergency Braking System and the Trending for Future Vehicles," Proceedings of the Southeast Asia Safer Mobility Symposium, 2013.
- [3]. Sidek, S. N., & Salami, M. J. E., "Design of Intelligent Braking System," IEEE TENCON Proceedings, vol. 2, pp. 580–585, 2000.
- [4]. Sharma, Y., Singh, S. S., Nawaz, M., Kaushik, V., Sharma, S., Sindhvani, R., & Singh, P. L., "Design, Analysis and Fabrication of Automatic Braking System," Advances in Engineering Design, Springer, Singapore, pp. 541–550, 2021.
- [5]. Ram, J., & Kumar, B., "Automatic Braking System Using Ultrasonic Sensor," International Journal of Innovative Science and Research Technology, vol. 2, no. 4, 2017.
- [6]. Coelingh, E., Eidehall, A., & Bengtsson, M., "Collision Warning with Full Auto Brake and Pedestrian Detection," IEEE Intelligent Transportation Systems Conference, pp. 155–160, 2010.
- [7]. Brännström, M., Coelingh, E., & Sjöberg, J., "Threat Assessment for Avoiding Collisions with Turning Vehicles," IEEE Intelligent Vehicles Symposium, pp. 663–668, 2009.
- [8]. Gavrilu, D. M., "Pedestrian Detection from a Moving Vehicle," European Conference on Computer Vision, Springer, Berlin, Heidelberg, pp. 37–49, 2000.
- [9]. Bose, N., & Murugan, R. S., "Automatic Braking System Assisted by Image and Video Processing for Pedestrian and Vehicle Detection Using MATLAB," International Journal of Information Technology & Computer Science Perspectives, vol. 2, no. 1, 2013.
- [10]. Chirantana, K., & Kanth, G. S. S., "Collision Warning with Automatic Braking System for Electric Cars," International Journal of Mechanical Engineering Research, 2015.
- [11]. Shivankar, H., et al., "Intelligent Braking System Using Infrared Sensor," International Journal of Engineering Research and Applications, 2017.
- [12]. Sai Ram, J. V., "Ultrasonic Sensor Based Automatic Braking System," International Journal of Engineering Science and Computing, 2018.

