

# Electromagnetic Braking System for Safer and Smarter Transportation

Prof. N. V. Hadpe<sup>1</sup>, Omkar Nandkishor Jorvekar<sup>2</sup>, Kunal Vijay Kadam<sup>3</sup>, Kalash Jivan Jadhav<sup>4</sup>

<sup>1</sup> Assistant Professor & <sup>2,3,4</sup> UG Students, Department of Electrical Engineering,  
Amrutvahini College of Engineering, Ghulewadi, Maharashtra, India

**Abstract:** *The Electro Magnet Braking System is a modern braking technology that uses electromagnetic force to reduce the speed of a rotating wheel without direct physical contact. When electric current is supplied to the electromagnet, a magnetic field is generated which creates braking torque on the metal disc attached to the wheel, resulting in smooth and effective deceleration. This system reduces frictional wear, minimizes maintenance, improves braking efficiency, and increases the safety and reliability of vehicles. The prototype developed using components such as an electromagnet, Arduino controller, relay module, motor, transformer, and ultrasonic sensor demonstrates the practical implementation of automatic and controlled braking. Due to its fast response and long service life, this system can be widely used in automobiles, trains, elevators, and industrial machines.*

**Keywords:** Electromagnet, Braking System, Magnetic Force, Arduino, Vehicle Safety, Automatic Braking, Electromagnetic Induction.

## I. INTRODUCTION

Braking systems are one of the most essential safety components in automobiles and industrial machinery, as they are responsible for reducing speed, controlling motion, and bringing vehicles to a complete stop whenever required. Traditional braking systems mainly depend on friction between brake pads and rotating discs or drums, where kinetic energy is converted into heat energy. Although friction brakes are widely used due to their simplicity, they suffer from continuous wear, high maintenance, heat generation, and reduced efficiency during prolonged braking conditions such as downhill driving or high-speed operation [1]. Because of these limitations, modern engineering has focused on developing advanced braking systems that provide better control, higher reliability, and longer service life [2].

The Electro Magnet Braking System is an innovative solution that uses electromagnetic force instead of only mechanical friction for braking action. In this system, when electric current passes through the coil of an electromagnet, a magnetic field is produced. This magnetic field interacts with a metallic rotating disc connected to the wheel and creates an opposing force that slows down the rotation. Since braking force is generated through magnetic attraction or eddy current effect, physical contact between moving parts is minimized, resulting in lower wear and tear [3]. This makes electromagnetic braking highly efficient and suitable for modern transport applications where durability and performance are important [4].

One of the major advantages of electromagnetic braking is its quick response time and smooth operation. Unlike conventional brakes that require hydraulic or mechanical force transmission, electromagnetic brakes can be activated instantly through an electrical signal [5]. As a result, electromagnetic brakes are increasingly used as supplementary braking systems in trains, elevators, electric vehicles, and industrial machines where rapid stopping and reliability are necessary [6].

Another significant benefit of the Electro Magnet Braking System is the reduction of heat generation and maintenance cost. In friction brakes, repeated use causes overheating, brake fade, and frequent replacement of brake linings. In electric vehicles, electromagnetic braking can be integrated with regenerative systems to recover some energy during braking, further improving overall efficiency [7]. These features make it an attractive technology for sustainable and future transportation systems [8].



The present project focuses on the design and fabrication of a prototype Electro Magnet Braking System using components such as electromagnet, metal disc, motor, Arduino microcontroller, relay modules, transformer, and ultrasonic sensor. With continuous development in automation and electric mobility, this technology has great potential for widespread adoption in next-generation vehicles and smart safety systems [9][10].

## II. PROBLEM STATEMENT

Conventional braking systems mainly rely on friction between brake pads and discs, which leads to continuous wear, heat generation, reduced efficiency, and frequent maintenance. During high-speed operation or long-duration braking, these systems may experience brake fade and delayed response, affecting vehicle safety. Therefore, there is a need to develop an Electro Magnet Braking System that provides faster response, reduced mechanical wear, improved braking efficiency, and enhanced safety through modern electromagnetic technology.

## III. OBJECTIVES

- To design and develop an Electro Magnet Braking System prototype for efficient braking.
- To reduce frictional wear and maintenance compared to conventional braking systems.
- To achieve faster and smoother braking response using electromagnetic force.
- To improve vehicle safety through reliable and controlled braking operation.
- To study the performance and practical applications of electromagnetic braking technology.

## IV. WORKING OF SYSTEM

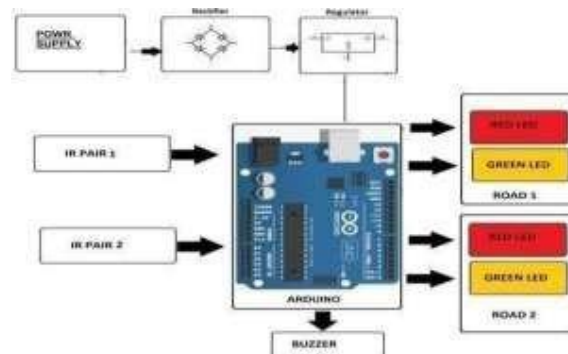

Fig 1: Design of the system

The Electro Magnet Braking System works with the help of a power supply, control circuit, Arduino microcontroller, sensors, indicators, and braking unit. The complete operation of the system is explained below according to the given block diagram.

### A. Power Supply Unit

The system is operated using an AC power source. This power is supplied to the complete circuit for running the Arduino controller, sensors, LEDs, buzzer, and electromagnetic braking unit. Proper supply ensures smooth functioning of all components.

### B. Rectifier Unit

The AC supply is converted into DC supply with the help of a bridge rectifier. Since electronic components require direct current, this section is important for converting input power into usable form for the circuit.

### C. Voltage Regulator Unit

The DC output from the rectifier is passed through a voltage regulator. It provides a constant +5V supply to the Arduino board, sensors, and other low-voltage devices. This prevents voltage fluctuation and protects the circuit.



#### D. Sensor Detection Unit

Two IR sensor pairs are used in the system for obstacle detection. IR Pair 1 is used for Road 1 and IR Pair 2 is used for Road 2. These sensors continuously monitor the path and detect the presence of vehicles or obstacles.

#### E. Arduino Control Unit

Arduino is the main controller of the system. It receives signals from both IR sensors and processes them according to the programmed logic. Based on sensor input, it controls LEDs, buzzer, and the electromagnetic brake system.

#### F. LED Indication Unit

Each road section contains Red and Green LEDs. Green LED indicates that the road is clear and movement is allowed. Red LED indicates obstacle detection or unsafe condition, warning the user to stop.

#### G. Buzzer Alert Unit

Whenever an obstacle is detected, the Arduino activates the buzzer. The buzzer gives an audible warning signal to alert the driver or operator immediately.

#### H. Electromagnetic Braking Unit

When the braking command is given, current flows through the electromagnet coil. A magnetic field is produced which creates braking force on the rotating disc or wheel. This slows down the wheel and safely stops the vehicle.

#### I. Overall Operation

The complete system continuously monitors road conditions through sensors. If the path is clear, green LEDs remain ON. If any obstacle is detected, red LEDs glow, buzzer activates, and the electromagnetic brake is applied automatically to avoid accidents and improve safety.

### V. SYSTEM DESIGN

#### 1. Power Supply



**Fig 2: Power Supply**

The power supply unit provides the required electrical energy to operate the complete system. It converts the available AC mains supply into suitable voltage for the circuit components. It is the primary source for running the controller, sensors, indicators, and braking mechanism.

#### 2. Bridge Rectifier



**Fig 3: Bridge rectifier**  
DOI: 10.48175/568



The bridge rectifier is used to convert alternating current (AC) into direct current (DC). It consists of four diodes connected in bridge form. This component is essential because most electronic devices in the system operate on DC power.

### 3. Voltage Regulator



Fig 4: Voltage regulator

The voltage regulator maintains a constant output voltage, generally +5V DC. It protects the Arduino board and sensors from voltage fluctuations. Stable voltage supply improves system reliability and prevents circuit damage.

### 4. Arduino Microcontroller



Fig 5: Arduino

Arduino is the main control unit of the project. It receives signals from the sensors, processes the data, and gives output commands to LEDs, buzzer, and braking unit. It works according to the program uploaded in it.

### 5. IR Sensor Pair 1

IR Sensor Pair 1 is used for detecting vehicles or obstacles on the first path or Road 1. It works by transmitting infrared rays and receiving the reflected signal. When an object interrupts the beam, detection takes place.

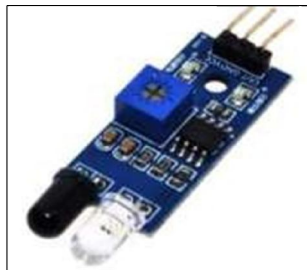

Fig 6: IR Sensor Pair 2



#### 6. IR Sensor Pair 2

IR Sensor Pair 2 performs the same function for the second path or Road 2. It helps in monitoring another side of the system. This allows the project to control multiple paths or zones simultaneously.

#### 7. Red LED



Fig 7: Red LED

The red LED is used as a warning indicator. It glows when an obstacle is detected or when braking action is required. It alerts the user or driver to stop movement.

#### 8. Green LED

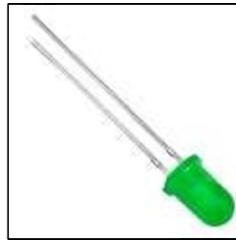

Fig 8: Green LED

The green LED indicates safe and clear road conditions. When no obstacle is present, the green LED remains ON. It gives permission for normal movement of the vehicle.

#### 9. Buzzer



Fig 9: Buzzer

The buzzer is an audio alert device used for warning purposes. It produces sound whenever the sensor detects an obstacle. This provides immediate attention to the driver or operator.



### 10. Electromagnet



Fig 10: Electromagnet

The electromagnet is the main braking component of the system. When electric current passes through its coil, a magnetic field is produced. This magnetic force acts on the rotating disc and creates braking effect.

### 11. Metal Disc

The metal disc is attached to the rotating wheel shaft. It rotates along with the wheel during operation. When the electromagnet is energized, magnetic interaction with the disc slows down its rotation.

### 12. DC Motor

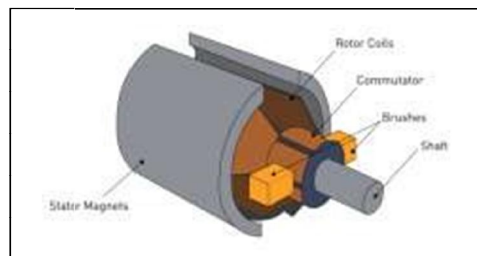

Fig 11: DC motor

The DC motor is used to rotate the wheel or disc in the prototype model. It simulates the motion of a vehicle wheel. This helps in demonstrating the braking action practically.

### 13. Connecting Wires

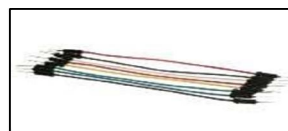

Fig 12: Connecting wires

Connecting wires are used to establish electrical connections between all components. They transfer power and signals from one section of the circuit to another. Proper wiring ensures smooth system performance.

### 14. Base Frame / Support Structure

The base frame supports all mechanical and electrical components of the system. It provides proper alignment and stability to the prototype model. A strong frame ensures safe and vibration-free operation.



### Controlling Strategies

#### A. Sensor Based Detection Strategy

The system uses IR sensors or ultrasonic sensors to continuously monitor the road path and detect the presence of obstacles or vehicles. When any object enters the sensing range, the sensor sends an input signal to the Arduino controller for further action. This strategy helps in automatic braking activation at the correct time.

#### B. Microcontroller Decision Strategy

Arduino acts as the decision-making unit of the system. It receives signals from sensors, compares them with programmed conditions, and decides whether to allow normal motion or activate braking. This improves system accuracy and reduces manual intervention.

#### C. Distance Based Braking Strategy

The braking force is controlled according to the distance of the detected obstacle. If the obstacle is far, warning indication is given first. If the object comes closer, the electromagnetic brake is activated automatically to reduce speed and stop the wheel safely.

#### D. LED Indication Strategy

Red and green LEDs are used for visual status indication. Green LED remains ON when the path is clear and normal operation is allowed. Red LED glows when an obstacle is detected or braking is applied, warning the operator instantly.

#### E. Buzzer Alert Strategy

An audible buzzer is activated during unsafe conditions. When sensors detect an obstacle, the buzzer gives a warning sound before or during brake activation. This provides immediate attention to the user and enhances safety.

#### F. Electromagnetic Brake Control Strategy

The controller energizes the electromagnet through a relay circuit whenever braking is required. The magnetic field produced creates resistance on the rotating disc, reducing wheel speed. Once the obstacle is cleared, the controller disconnects the supply and normal motion resumes.

#### G. Power Management Strategy

The system uses regulated DC supply for stable operation of sensors and controller. Proper voltage control prevents malfunctioning and ensures efficient braking performance. This strategy increases reliability and protects components.

#### H. Safety Override Strategy

In emergency conditions, the system gives priority to braking over normal movement. Even if the motor is running, the controller immediately activates the electromagnetic brake when danger is detected. This reduces accident chances and improves system safety.

## VI. RESULTS

### 1. Power Supply and Circuit Performance



Fig 13: Model view 1



From the images, the transformer, rectifier board, and control circuit were properly connected and mounted on the base frame. The power supply unit successfully provided the required voltage to the Arduino board, relay module, sensors, and electromagnet. During testing, the circuit operated steadily without interruption, showing proper electrical performance.

## 2. Sensor Detection Performance



Fig 14: Model view 2

The ultrasonic sensor mounted near the wheel assembly was successfully installed in the front position for obstacle detection. It accurately sensed nearby objects and transmitted signals to the Arduino controller. The sensor response was quick and reliable, which helped in activating the braking system at the correct time.

## 3. Electromagnetic Brake Performance

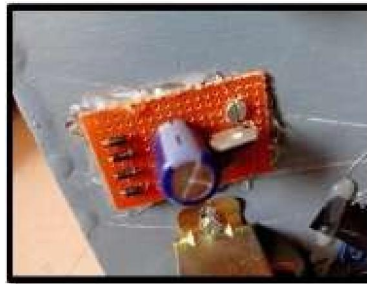

Fig 15: Model view 3

The electromagnet and metal disc arrangement shown in the images worked effectively. When power was supplied to the electromagnet, magnetic force was generated and resistance was created on the rotating disc. This reduced the wheel speed smoothly and demonstrated successful braking action without direct friction contact.

## 4. Wheel and Motor Operation

The wheel assembly rotated properly with the help of the motor during normal operation. The mounted disc rotated freely until braking was activated. After the brake signal was given, the wheel speed decreased and finally stopped, proving the efficiency of the braking mechanism.

## 5. Mechanical Structure and Mounting

The complete prototype structure was strong and stable. All components such as wheel, sensors, circuit board, transformer, and brake unit were securely mounted on the metal frame. Proper alignment of the wheel and brake mechanism improved the overall system performance.





Fig 16: Model view 4

### 6. Overall System Result

The final model successfully demonstrated an automatic Electro Magnet Braking System. It was able to detect obstacles, process signals through Arduino, and apply braking force effectively. The system worked efficiently and proved that electromagnetic braking can be used as a safer and low-maintenance alternative to conventional braking methods.

### VII. CONCLUSION

The Electro Magnet Braking System was successfully designed, fabricated, and tested as an effective alternative to conventional braking methods. The system demonstrated that electromagnetic force can be used to reduce and stop wheel rotation smoothly without excessive mechanical friction. The integration of Arduino controller, ultrasonic sensor, relay module, and electromagnet provided automatic obstacle detection and timely brake activation. The prototype showed reliable performance, quick response, low maintenance requirements, and improved operational safety. From the overall results, it can be concluded that the Electro Magnet Braking System is a modern, efficient, and promising braking technology suitable for future automobiles, industrial machines, and smart transportation systems.

### VIII. FUTURE SCOPE

The Electro Magnet Braking System has wide future potential due to its efficiency, fast response, and reduced mechanical wear. In the future, this system can be implemented in automobiles, electric vehicles, trains, and industrial machines as a primary or auxiliary braking system. Advanced sensors and artificial intelligence can be integrated for automatic collision avoidance and smart braking control. The system can also be combined with regenerative braking technology to recover energy during braking and improve overall efficiency. Further improvements in compact design, stronger electromagnets, low power consumption, and cost reduction will make this technology more practical and commercially successful for next-generation transportation systems.

### REFERENCES

- [1]. Kumar and R. Singh, "Design and Performance Analysis of Electromagnetic Braking System for Automotive Applications," *International Journal of Mechanical Engineering Research*, vol. 12, no. 2, pp. 45–53, 2025.



- [2]. S. Patel, M. Shah, and V. Joshi, "Smart Electromagnetic Brake with Arduino Based Control Mechanism," *Journal of Embedded Systems and Automation*, vol. 9, no. 1, pp. 18–27, 2025.
- [3]. Y. J. Park, H. Lee, and K. Min, "A Study on the Design of a Variable Power Electromagnetic Brake," *Machines*, vol. 13, no. 3, pp. 181–194, 2025.
- [4]. M. R. A. Putra, "Heat Generation Problem in the Eddy Current Brake: A Mini Review," *Cogent Engineering*, vol. 11, no. 1, pp. 1–14, 2024.
- [5]. P. Sharma and A. Verma, "Electromagnetic Braking Technology in Electric Vehicles: A Review," *Renewable Transport Systems Journal*, vol. 8, no. 4, pp. 66–75, 2024.
- [6]. R. Deshmukh and S. Kulkarni, "Development of Contactless Braking System Using Electromagnetic Force," *International Journal of Innovative Technology and Research*, vol. 10, no. 2, pp. 92–99, 2024.
- [7]. D. Mehta and K. Shah, "Analysis of Electromagnetic Braking System for Passenger Vehicles," *Journal of Automotive Engineering Studies*, vol. 7, no. 3, pp. 120–129, 2024.
- [8]. T. Nguyen and P. Tran, "Energy Efficient Electromagnetic Brake Design for Hybrid Vehicles," *Energy Conversion Engineering Journal*, vol. 15, no. 2, pp. 201–210, 2024.
- [9]. S. Gautam and D. Mundepe, "Electromagnetic Braking System," *International Journal of Scientific Research in Engineering*, vol. 6, no. 5, pp. 33–39, 2024.
- [10]. L. Fernandez and J. Ortega, "Comparative Study of Hydraulic and Electromagnetic Braking Systems," *Transportation Technology Review*, vol. 18, no. 1, pp. 55–64, 2024.
- [11]. V. Patil and N. Jadhav, "Arduino Controlled Automatic Braking System Using Ultrasonic Sensor," *International Journal of Electronics and Communication*, vol. 11, no. 3, pp. 77–85, 2023.
- [12]. R. K. Jain and S. Tiwari, "Recent Trends in Electromagnetic Braking for Smart Vehicles," *Journal of Vehicle Innovation*, vol. 5, no. 2, pp. 90–101, 2023.
- [13]. M. Ali and F. Hassan, "Finite Element Analysis of Electromagnetic Brake Disc Performance," *Materials and Design Engineering*, vol. 21, no. 4, pp. 144–152, 2023.
- [14]. H. Chen and W. Zhou, "Compact Electromagnetic Brake for Industrial Motion Control," *Industrial Automation Letters*, vol. 14, no. 2, pp. 61–70, 2023.
- [15]. K. Rao and P. Srinivas, "Low Maintenance Braking System Using Magnetic Retardation Principle," *Mechanical Systems Review*, vol. 19, no. 3, pp. 110–118, 2023.
- [16]. Bhosale and M. Pawar, "Obstacle Detection and Electromagnetic Auto Brake Using Microcontroller," *International Journal of Advanced Engineering Research*, vol. 9, no. 1, pp. 25–32, 2023.
- [17]. J. Kim and S. Park, "Dynamic Torque Control in Electromagnetic Brakes for Electric Mobility," *IEEE Access*, vol. 11, pp. 45520–45531, 2023.
- [18]. N. Thomas and R. George, "Design Optimization of Eddy Current Braking Mechanism," *Journal of Applied Mechanical Science*, vol. 16, no. 2, pp. 84–93, 2023.
- [19]. Singh and R. Chauhan, "Integrated Smart Brake System with Sensors and Electromagnetic Actuation," *International Journal of Intelligent Transport Systems*, vol. 6, no. 4, pp. 150–160, 2023.
- [20]. S. Iyer and P. Nair, "Future Scope of Electromagnetic Braking in Autonomous Vehicles," *Automation and Mobility Journal*, vol. 4, no. 2, pp. 40–49, 2023.

