

Enchaining The Stability Margin and Transmission Capability of EPS By Using STATCOM as Compensator

Mr. Akash G. Dhekane¹, Prof. Y. P. Sushir², Prof. J. R. Hanumant³

Students, Department of Electrical Engg, Dr. V. B. Kolte College of Engineering, Malkapur, India ¹
Professor, Department of Electrical Engg, Dr. V. B. Kolte College of Engineering, Malkapur, India ^{2,3}

Abstract: A STATCOM is employed to improve the power factor at the load end in this article. The power factor of the loads connected to the network determines the degree of power use. Because most of the loads in the distribution line are inductive, they require a significant amount of reactive power. As a result, the load's power factor degrades, causing the active power flow in the line to be limited. Higher current, more losses, and a voltage dip in the line are all consequences of a poor power factor. For load correction, reactive power regulation is required. The goal of this study is to design a STATCOM that uses a voltage-source converter to improve the load's power factor locally by injecting appropriate reactive power into the power distribution line. The STATCOM is controlled by a H controller. The MATLAB/ Simulink implementation of the D-S TATCOM and hysteresis controller is completed

Keywords: STATCOM, voltage source converter, load compensation, power factor, reactive power

I. INTRODUCTION

Load centres are typically located distant from power producing units, a transmission and distribution network is constructed to meet the load demand. "The voltage profile deteriorates and system stability suffers as a result of overloaded transmission lines. The power factor of the loads connected to the network determines the degree of power use. Because most of the loads in the distribution line are inductive, they require a significant amount of reactive power [1]. As a result, the load's power factor degrades, causing the active power flow in the line to be limited. This necessitates reactive power control for load compensation to improve the power factor. By making the amplitude of its output voltage surpass the ac supply system voltage, a VSC-based STATCOM can be made to inject reactive power into the ac supply system to increase the power factor and for reactive power compensation. A three-phase voltage source converter with a dc bus capacitor is used as a D-STATCOM in this work for source current balancing, power factor correction, and harmonic abatement in a three-phase, three-wire distribution system serving delta linked load under varied source voltage situations. The capacity to create reference compensator currents is one of the main reasons to choose STATCOM as a load compensator. To balance out disturbances generated by the load, the compensator injects three-phase currents into the ac system by following the reference currents [2]-[2]. In light of these circumstances, this study offers the modelling of a STATCOM based on three-phase VSC to increase the load end power factor. [3-5] explains how they use a PV solar farm as a STATCOM during the night".

II. PROPOSED WORK

A D-STATCOM based on a voltage-source converter (VSC) has been proposed in this research to improve the load's power factor locally by injecting appropriate reactive power into the power distribution line. "For the aim of managing the VAR generation, the amplitude of the D-output STATCOM's voltage is made bigger than the system voltage. As a result, it can generate capacitive reactive power internally for shunt correction. A Hysteresis controller is used to control the D-STATCOM [6]. The STATCOM is programmed to track the power factor reference and keep it constant in the line. The D-STATCOM and its controller are implemented in MATLAB/ Simulink. STATCOM is the stationary

Copyright to IJARSCT

www.ijarsct.co.in



DOI: 10.48175/IJARSCT-33743



311

counterpart to the rotating synchronous condenser, which generates or absorbs reactive power more quickly by controlling the inverted voltage in relation to the ac supply line voltage. D-STATCOM is the name given to it when it is utilised in distribution systems as shown in fig. 1. It can produce a sinusoidal voltage of any amplitude, frequency, or phase angle". Furthermore, the converter is usually based on some form of energy storage that provides a DC voltage to the converter. A dc capacitor, three-phase inverter, coupling transformer, and controller are the basic components of D-STATCOM.

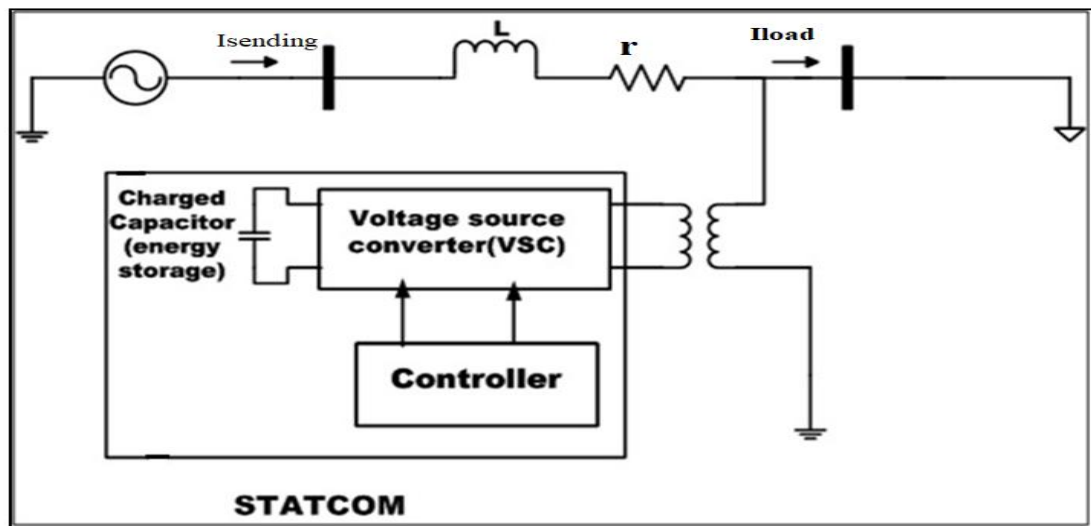

Fig. 1 STATCOM with system

III. STATCOM CONTROLLER

Capacitive type: The VSC injects reactive power into the ac system when its output voltage is greater than the ac system voltage. As a result, it operates in the capacitive mode, with the ac system drawing capacitive current that leads the system voltage.

Inductive type; When the ac system voltage is higher than the VSC's output voltage, the VSC absorbs reactive power from the ac system. As a result, it operates inductively here.

Floating type: When the VSC's output voltage equals the ac system voltage, the VSC acts in floating mode, generating and absorbing no reactive power.

"The Hysteresis-band PWM is a type of instantaneous feedback current control in which the real current follows the command current with a hysteresis band [7-9]. The sine reference current wave of desired amplitude and frequency is generated by the control circuit and compared to the real phase current wave. The upper switch in the half-bridge is turned off and the lower switch is turned on when the current exceeds a prescribed hysteresis band. The lower switch is turned off and the top switch is turned on as the current crosses the lower band limit. At each transition, a lock-out time(t_d) is provided to prevent a shoot-through fault. By switching the upper and lower switches back and forth, the actual current wave is forced to track the sine reference wave inside the hysteresis region" [10-14].

The inverter effectively transforms into a current source with peak-to-peak current ripple that can be regulated within the hysteresis band regardless of V_d fluctuations. The breadth of the hysteresis band affects the peak-to-peak ripple and switching frequency [15]. Fig. 2 depicts the proposed hysteresis controller. by infusing the reactive component current into the system, which modulates the voltage. The reactive current required for power factor adjustment is calculated based on the load current.



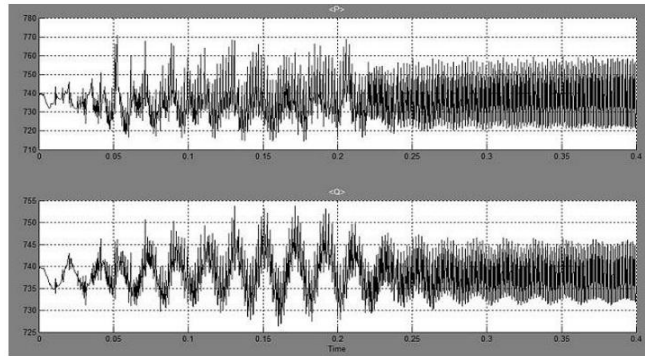

Fig.4 Real and Reactive power without capacitor

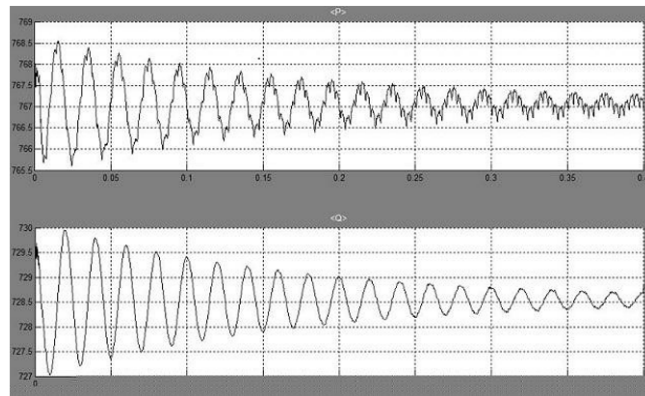

Fig.5 Real and Reactive power with capacitor

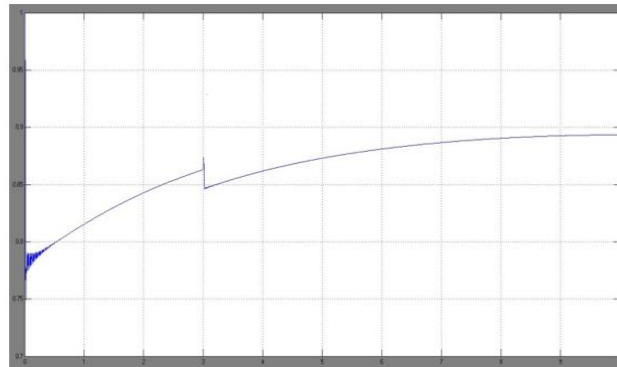

Fig.6 Real and Reactive power with STATCOM

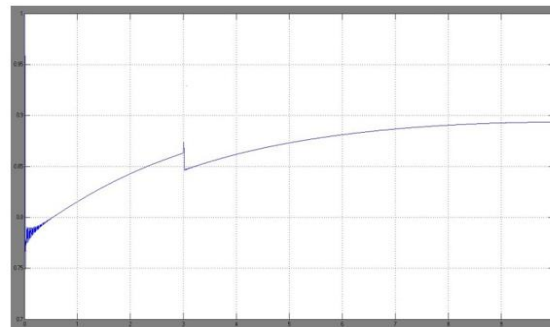

Fig. 7 Power factor improvement

DOI: 10.48175/IJAR SCT-33743



“Fig. 4 and 5 show the actual and reactive power before and after the capacitor was added. The capacitor injects reactive power into the line, reducing the reactive power absorbed by the line. The switching is done mechanically in this case. The response time is slow, and capacitance can only be changed in steps. The capacitance value can't be changed all the time. This approach cannot be used in situations that demand a high level of compensation. As a result, FACTS, a power electronics-based technology, is used. D- STATCOM has the ability to manage reactive power as needed. It is possible to have fine control and quick response here. Fig. 7 depicts the D-STATCOM-enabled system. To increase the power factor, D- STATCOM is used instead of capacitive compensation. The D-STATCOM controller consists of a hysteresis band controller for generating pulses, reference current generation, power factor generation, calculation of current necessary to inject reactive power, and a reference current generator. The current and voltages in the system are measured and sent to the controller. As a reference, the power factor that must be maintained is supplied. The reactive power necessary to maintain the reference power factor is computed using the reactive power in the line”.

V. CONCLUSION

“This paper shows how to implement D-STATCOM and its controller using a simulation technique. By infusing the reactive component current into the system, the hysteresis controller regulates the voltage regulation. The reactive current required for power factor adjustment is then calculated based on the load current. By injecting appropriate reactive power into the power distribution line, the proposed solution enhances the load's power factor locally. Because of the enhanced power factor, the total electrical system performance is improved by lowering line losses”.

REFERENCES

- [1]. K. Somsai and T. Kulworawanichpong, “Instantaneous Power Control of D-STATCOM with Consideration of Power Factor Correction”, Power System Research Unit, School of Electrical Engineering, Suranaree University of Technology Nakhon Ratchasima, Thailand 30000, April 3, 2014.
- [2]. Sabha Raj Arya, Bhim Singh, Ambrish Chandra and Kamal Al- Haddad, “Power Factor Correction and Zero Voltage Regulation in Distribution System Using DSTATCOM”, IEEE International Conference on Power Electronics, Drives and Energy Systems December 16-19, 2012,
- [3]. Kolli Nageswar Rao, C. Hari Krishna, Kiran Kumar Kuthadi, “ Implementation of D-STACTOM for Improvement of Power Quality in Radial Distribution System”, International Journal of Modern Engineering Research (IJMER) Vol. 2, Issue. 5, Sep.-Oct. 2012 pp-3548-3552.
- [4]. Tejas Zaveri, B.R. Bhalja and Naimish Zaveri, “Load compensation using DSTATCOM in three-phase, three-wire distribution system under various source voltage and delta connected load conditions,”Journal of Electrical Power and Energy Systems, vol. 41, pp. 34–43, 2012.
- [5]. Rajiv. K. Varma, Shriram. S. Rangarajan, Iurie Axente, Vinay Sharma, “Novel Application of a PV Solar Plant as STATCOM during Night and Day in a Distribution Utility Network”, 2011 IEEE PES Power Systems Conference & Exposition, March 20- 23, 2011, Phoenix, Arizona, USA.
- [6]. R.K. Varma, V. Khadkikar and R. Seethapathy, "Nighttime Application of PV Solar Farm as STATCOM to Regulate Grid Voltage," IEEE Trans. on Energy Conversion (Letters), vol.24, no.4,2009, pp.983-985 Rajiv K. Varma and Vinod Khadkikar, “Utilization Of Solar Farm Inverter as STATCOM”, USProvisional Patent application filed 15 Sept. 2009.
- [7]. A new approach to load balancing and power factor correction in power distribution system,” IEEE Trans. Power Delivery, vol. 15, 2000, pp.417–422,
- [8]. H. Akagi, Y. Kanazawa, and A. Nabae, “Instantaneous reactive power compensators comprising switching devices without energy storage components,” IEEE Trans. Ind. Applicat., vol. IA-20, 1984, pp. 625–630
- [9]. S.Siva Kesava Reddy, A. R. Vijay Babu, S. Suman, K.Divya Manasa, “ Reactive Power Compensation Using DSTATCOM”, International Journal of Engineering Research and Applications , pp: 1-6.



- [10]. R. Shah, N. Mithulananthan, R. Bansal, and V. Ramachandaramurthy, "A review of key power system stability challenges for large-scale PV integration," *Renewable Sustain. Energy Rev.*, vol. 41, pp. 1423–1436, 2015.
- [11]. "Reliability Standards for the Bulk Electric Systems of North America," North Amer. Elect. Rel. Corp., Atlanta, GA, USA, 2017.
- [12]. R. K. Varma, S. A. Rahman, and T. Vanderheide, "New control of PV solar farm as STATCOM (PV-STATCOM) for increasing grid power transmission limits during night and day," *IEEE Trans. Power Del.*, vol. 30, no. 2, pp. 755–763, Apr. 2015.
- [13]. R. G. Wandhare and V. Agarwal, "Novel stability enhancing control strategy for centralized PV-Grid systems for smart grid applications," *IEEE Trans. Smart Grid*, vol. 5, no. 3, pp. 1389–1396, May 2014.
- [14]. A. Reznik, M. G. Simoes, A. Al-Durra, and S. Muyeen, "LCL filter design and performance analysis for grid-interconnected systems," *IEEE Trans. Ind. Appl.*, vol. 50, no. 2, pp. 1225–1232, Mar./Apr. 2014.
- [15]. "ERCOT Nodal Operating Guides," Elect. Rel. Council Texas, Austin, TX, USA, 2015

