

# **Mobile Controlled Wheeled Robotics ARM**

**Mr. Abhishek Mahavir Sone, Mr. Ritesh Sidram Bavi, Mr. Neeraj Ramesh Madgundi**

**Mr. Pratik Vikas Sawale, Mr. Alfaj Hasan Mulani**

**Prof. N. N. Shaikh, Prof. H. R. Dhananjaya**

Dept. of Electrical Engineering

Brahmdevdada Mane Institute of Technology, Solapur.

**Abstract:** *The project titled "Mobile Controlled Wheeled Robotic Arm" represents a multidisciplinary integration of robotics, embedded systems, control engineering, and communication technology. The main goal of this project is to develop a cost-effective, intelligent, and mobile robotic arm that can be controlled wirelessly via a smartphone. The robot is designed to perform object manipulation tasks such as lifting, carrying, and placing items while maintaining mobility through a wheeled base. The microcontroller at the heart of this system is the ESP32, a powerful dual-core processor with built-in Bluetooth and Wi-Fi functionalities. This eliminates the need for an external communication module such as the HC-05, simplifying the design and improving system efficiency.*

*The robotic system is divided into two major sections: the wheeled base, responsible for navigation, and the robotic arm, responsible for performing manipulation tasks. The integration of mobility and manipulation capabilities creates a flexible platform that can be applied in various environments—industrial, domestic, educational, and hazardous zones. The ESP32 acts as the brain of the system, processing incoming wireless commands and generating precise control signals for DC motors and servo motors via an L298N motor driver. The mobile application sends control instructions using Bluetooth, which are received and executed by the ESP32 in real time.*

*The project demonstrates how automation can reduce human effort, increase operational precision, and improve safety in complex working environments. The use of mobile control provides remote access, making it ideal for applications such as warehouse operations, disaster response, or handling harmful materials. Beyond its functional aspects, this project serves as a learning model for engineering students to understand robotics architecture, embedded programming, motor control, and communication protocols. Overall, the Mobile Controlled Wheeled Robotic Arm is a compact, scalable, and practical robotic system that bridges theoretical concepts with real-world applications.*

**Keywords:** *Mobile Controlled Wheeled Robotic Arm*

## **I. INTRODUCTION**

In today's world, robotics has become an essential component in the evolution of modern technology. Robotics combines mechanical design, electronic control, and intelligent programming to perform complex tasks that were once limited to human capability. The Mobile Controlled Wheeled Robotic Arm project aims to demonstrate how these domains converge to produce a low-cost and efficient system capable of remote operation. The robot merges two critical aspects of robotics: mobility and manipulation. A mobile base allows the robot to traverse various surfaces, while the robotic arm enables it to interact physically with objects.

The integration of wireless control through a smartphone enhances usability, accessibility, and safety. Operators can maneuver the robot from a distance without being exposed to potentially dangerous conditions, making it suitable for use in chemical industries, nuclear plants, or defense applications. The ESP32 microcontroller, chosen for this project, plays a central role. Its dual-core processor offers high-speed computation, while its built-in Bluetooth interface enables



smooth communication between the mobile device and the robot. Unlike traditional systems requiring additional modules, the ESP32 simplifies circuit design, minimizes power consumption, and reduces latency.

This project highlights the increasing need for automation across multiple sectors. In industrial settings, robotic systems improve efficiency and accuracy. In healthcare, they assist disabled individuals or support teleoperation. In education, they serve as practical tools for teaching embedded systems and control mechanisms. The Mobile Controlled Wheeled Robotic Arm project also introduces students to real-world challenges in mechanical assembly, motor interfacing, and mobile application integration. By achieving mobility and manipulation within single platform, the project demonstrates how robotics can enhance human capabilities and revolutionize automation practices worldwide.

## **II. LITERATURE SURVEY**

The development of robotic systems has evolved significantly over the past few decades. Early research in robotics primarily focused on stationary arms used for assembly line manufacturing. These robots lacked mobility and were limited to repetitive operations. However, with advancements in embedded systems and wireless technology, researchers began developing mobile platforms that could be remotely operated. Many academic papers and industrial projects have explored mobile robotic arms using microcontrollers like Arduino and Raspberry Pi. These systems often relied on Bluetooth modules such as HC-05 or HC-06 for wireless communication.

A study published in IEEE Transactions on Robotics emphasized the importance of combining manipulation and mobility to enhance the versatility of robots. Earlier designs often required multiple microcontrollers to handle communication and motor control separately, resulting in higher costs and complex wiring. The ESP32 microcontroller has emerged as a solution to these limitations by integrating Bluetooth and Wi-Fi on a single chip while offering more GPIO pins and faster processing. Researchers have demonstrated its effectiveness in IoT-based robotic systems, making it a preferred choice for modern applications.

Additionally, the use of L298N motor drivers remains common in robotic projects due to their ability to handle multiple motors simultaneously and provide directional control. Several comparative analyses indicate that the ESP32 offers better performance and scalability than the Arduino UNO for complex robotics projects. The integration of mobile applications with Bluetooth interfaces allows users to control robots intuitively. By building upon previous research, this project adopts a simplified architecture that maximizes efficiency while reducing cost. The Mobile Controlled Wheeled Robotic Arm thus aligns with the latest trends in automation, IoT, and embedded intelligence, offering a practical and educational model for future innovation.

## **OBJECTIVE**

The objectives of the Mobile Controlled Wheeled Robotic Arm project are multi-faceted and focus on combining functionality, usability, and educational value. The primary aim is to design and implement a robotic system that integrates both mobility and manipulation capabilities controlled wirelessly through a mobile device. The specific objectives include:

- ▶ To design and develop a mobile-controlled robotic arm using the ESP32 microcontroller as the central control unit.
- ▶ To implement a wireless control system utilizing the ESP32's built-in Bluetooth feature to eliminate external modules and simplify communication.
- ▶ To enable real-time bidirectional communication between the mobile application and the robotic system.
- ▶ To develop precise motor control for both the wheeled base and the robotic arm using the L298N motor driver and servo motors.
- ▶ To ensure the robot is compact, cost-effective, and capable of operating in both educational and industrial environments.

The project also aims to enhance the understanding of embedded systems by providing hands-on experience with ESP32 programming, motor control algorithms, and wireless interfacing. A key goal is to reduce dependency on



manual labor in repetitive or hazardous tasks, replacing them with efficient automated solutions. Furthermore, the system architecture is designed to be modular, allowing future upgrades such as Wi-Fi control, camera integration, and AI-based object detection. The project demonstrates how low-cost components can be used innovatively to build a functional, scalable robotic system suitable for a wide range of applications.

### BLOCK DIAGRAM

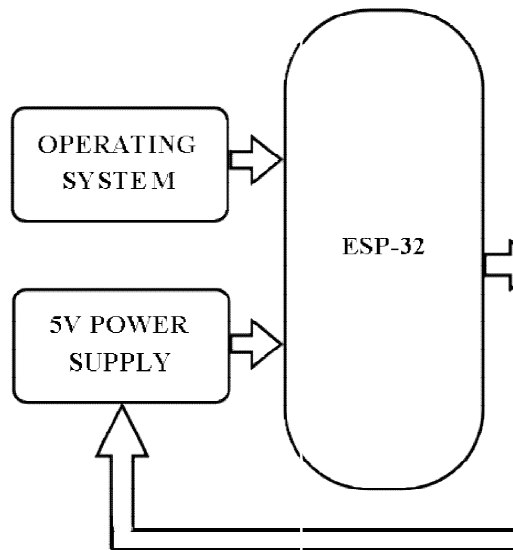

The Circuit Diagram represents the overall architecture of the Wheeled Robotic Arm prototype, showing the interaction between various motors and the ESP-32, wiring connections, control systems, and output devices. It provides a clear understanding of how each component contributes to the functionality of the project.

#### Description of the Block Diagram:

##### ► ESP-32

The ESP32 serves as the central control unit of the entire system. It processes all commands received wirelessly through Bluetooth from the mobile device and generates appropriate control signals for both DC and servo motors. Its dual-core processor provides high-speed computation, and the built-in Bluetooth module eliminates the need for an external communication device like HC-05. The ESP32 also supports multiple PWM outputs required for controlling servo and DC gear motors simultaneously.

##### ► Motor Drive

The L298N motor driver is used to interface the ESP32 with six DC gear motors. It acts as a bridge between the low-power microcontroller and high-current motors. The module allows bidirectional control of motor rotation, enabling forward, backward, left, and right movement. It includes built-in heat sinks to prevent overheating and supports independent control of two motor channels, which can be combined to drive multiple motors through logical wiring.



► **DC Gear Motor**

Six high-torque DC gear motors are used to drive the wheels of the rocker-bogie base. Each motor provides sufficient torque to move the robot smoothly across uneven surfaces. The gear reduction mechanism increases torque while reducing speed, ensuring precise and stable movement. These motors are powered through the L298N driver and respond quickly to control signals from the ESP32.

► **Servo Motor**

Five servo motors are used to control the joints of the robotic arm-base rotation, shoulder, elbow, wrist, and gripper. Each servo motor operates using PWM signals from the ESP32, allowing precise control of angular movement between 0° and 180°. The gripper servo helps in gripping and releasing objects, while the others handle lifting and rotation.

**CIRCUIT DIAGRAM**

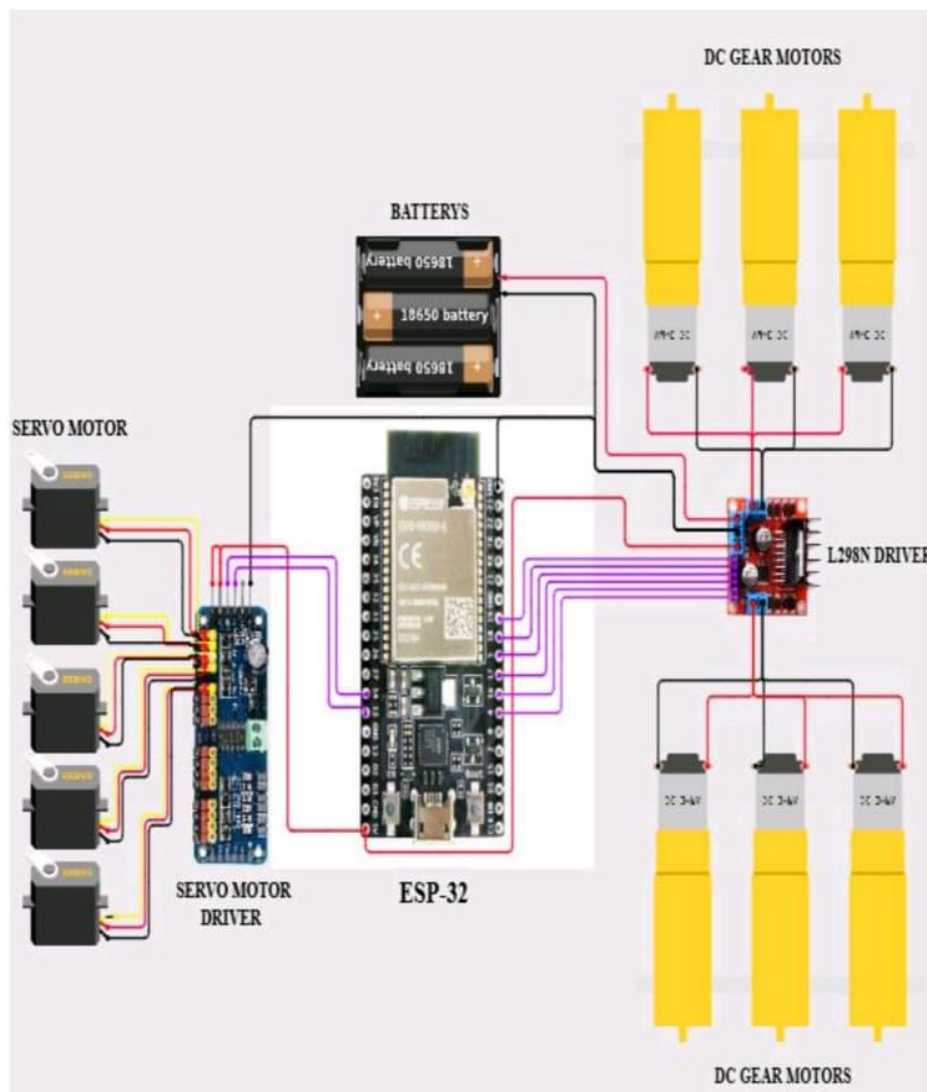

### **III. WORKING**

The “**Mobile Controlled Wheeled Robotic Arm**” operates on the integration of embedded systems, motor control, wireless communication, and mechanical design. Its working principle involves the coordination between the ESP32 microcontroller, five servo motors, six DC gear motors, and a rocker-bogie chassis system, all of which are controlled through a mobile application via Bluetooth communication. The project aims to demonstrate how mobility and manipulation can coexist in a single robotic platform for performing operations such as object handling, transportation, and placement.

#### **1. Working of Wheeled Robotic Arm System Central Control (ESP32 Microcontroller)**

The entire system is controlled by an ESP32 board. It acts as the brain of the system, handling both motion control and arm operations. The ESP32 receives commands from a user interface (like a mobile app or web page) through Wi-Fi or Bluetooth and sends appropriate signals to motor drivers controlling movement and arm actions.

#### **2. Locomotion (DC Gear Motors with DC Motor Drive)**

The base of the robot consists of wheels powered by DC gear motors. These motors provide the torque needed for smooth movement on flat surfaces. The speed and direction of the DC motors are controlled by a DC motor driver, which receives control signals from the ESP32. By adjusting the PWM signals, the robot can move forward, backward, or rotate in place.

#### **3. Arm Control (Servo Motors with Servo Motor Driver)**

The robotic arm is operated using multiple servo motors, each controlling a specific joint such as base rotation, shoulder, elbow, and gripper. The servo motor driver interfaces between the ESP32 and the servos, ensuring precise position control. The ESP32 sends angle commands to the servo driver, allowing the arm to perform tasks like picking, lifting, and placing objects.

#### **4. Power Supply System**

A regulated power source supplies the ESP32, motor drivers, DC motors, and servos. Each module receives voltage through proper converters to avoid overload or damage.

#### **5. Communication and Control Interface**

The system can be wirelessly operated, making it ideal for showroom demonstrations where ease of control and mobility are essential.

#### **6. Summary of Operation**

The Mobile Controlled Wheeled Robotic Arm effectively demonstrates a robust and flexible robotic system. ESP32 acts as the control hub, seamlessly managing communication, decision-making, and actuation. The rocker-bogie base ensures mobility and terrain adaptability, while the five servo motors provide smooth, articulated motion for precise arm operation. By combining these subsystems, the robot can navigate, lift, and manipulate objects under full wireless control representing a perfect balance of mechanical design and intelligent control.

In this project, the ESP32 acts as the central controller coordinating both the wheeled movement and robotic arm operations. The DC motor drive enables chassis motion, while the servo motor drive controls precise arm movements. Together, they form a mobile robotic arm capable of remote-controlled operations, suitable for tasks like object handling and display automation in showrooms.

### **IV. REQUIRED COMPONENTS**

- 1) ESP32,
- 2) L298N Motor Driver,
- 3) 3V-12V DC Gear Motors,
- 4) Wheels,
- 5) Servo Motors,
- 6) Battery's,
- 7) Wires,



- 8) Mechanical Structure,
- 9) Rocker-bogie chassis.

#### **V. EXPECTED RESULT**

The expected result of the Mobile Controlled Wheeled Robotic Arm project is to develop a fully functional robotic system capable of performing movement and manipulation tasks through wireless control using a smartphone. The robot should demonstrate smooth mobility, accurate arm movement, and reliable Bluetooth communication between the mobile device and the ESP32 microcontroller. The following outcomes are expected from the system.

##### **A. Accurate Wireless Control**

The ESP32's built-in Bluetooth module ensures stable and low-latency communication between the mobile application and the robot. When a command is given through the smartphone, the corresponding action should occur immediately without signal delay or misinterpretation. Each button press (such as forward, backward, arm up, or grip close) is expected to generate a specific response in real time, confirming the success of wireless control.

##### **B. Smooth Mobility with Rocker-Bogie Base**

The six DC gear motors mounted on the rocker-bogie structure should provide high stability and traction even on uneven surfaces. The robot is expected to move forward, backward, and turn in both directions with minimal vibration or slippage. The differential drive configuration should allow smooth turning and maintain balance when navigating small obstacles, showcasing the robustness of the rocker-bogie mechanism.

##### **C. Precise Arm Movement using Servo Motors**

The five servo motors controlling the robotic arm should operate precisely according to the user's commands. Each joint-base rotation, shoulder, elbow, wrist, and gripper must move to the desired angle with accuracy and repeatability. The arm should be able to lift light-weight objects, hold them firmly using the gripper, and place them in the target position without losing stability or precision.

#### **VI. ADVANTAGES**

- Freedom of degree to movement
- Wireless Control
- Low-Cost Design
- Compact and Portable
- High Stability
- Accurate Arm Control
- Energy Efficiency
- Educational Value
- Scalability

#### **VII. FUTURE SCOPE**

- Integration of Artificial Intelligence (AI)
- Camera-Based Vision System
- IoT Connectivity
- Voice Control Interface
- Autonomous Navigation
- Enhanced Payload Capacity
- Gesture Control
- Smart Factory Applications



**REFERENCES**

- [1] J. J. Craig, *Introduction to Robotics: Mechanics and Control*, 3rd ed. Upper Saddle River, NJ, USA: Pearson Education, 2005.
- [2] M. Spong, S. Hutchinson, and M. Vidyasagar, *Robot Modeling and Control*. New York, NY, USA: Wiley, 2006.
- [3] R. Siegwart, I. R. Nourbakhsh, and D. Scaramuzza, *Introduction to Autonomous Mobile Robots*, 2nd ed. Cambridge, MA, USA: MIT Press, 2011.
- [4] B. Siciliano and O. Khatib, *Springer Handbook of Robotics*. Berlin, Germany: Springer, 2016.
- [5] K. S. Fu, R. C. Gonzalez, and C. S. G. Lee, *Robotics: Control, Sensing, Vision, and Intelligence*. New York, NY, USA: McGraw-Hill, 1987.
- [6] A. Ollero, "Mobile robot navigation and localization," in *Advanced Robotics*, vol. 15, no. 3, pp. 345–367, 2001.
- [7] T. Yoshikawa, "Manipulability of robotic mechanisms," *The International Journal of Robotics Research*, vol. 4, no. 2, pp. 3–9, 1985.
- [8] S. Thrun, W. Burgard, and D. Fox, *Probabilistic Robotics*. Cambridge, MA, USA: MIT Press, 2005.
- [9] R. Murphy, *Introduction to AI Robotics*. Cambridge, MA, USA: MIT Press, 2019.
- [10] P. Corke, *Robotics, Vision and Control: Fundamental Algorithms in MATLAB*. Cham, Switzerland: Springer, 2017.
- [11] N. J. Nilsson, *Artificial Intelligence: A New Synthesis*. San Francisco, CA, USA: Morgan Kaufmann, 1998.
- [12] G. Dudek and M. Jenkin, *Computational Principles of Mobile Robotics*. Cambridge, UK: Cambridge University Press, 2010.

