

# Comparative Study of Emerson DeltaV and Honeywell Experion PKS DCS Systems

Upadhyay Khushi and Prof. Chirag S. Dalal

B.Tech 4<sup>th</sup> year Student, Department of Instrumentation and Control<sup>1</sup>

Associate Professor, Department of Instrumentation and Control<sup>2</sup>

Dharmsinh Desai University, Nadiad, Gujarat, India

**Abstract:** *Distributed Control Systems (DCS) are the backbone of modern industrial automation, enabling centralized monitoring, control, and optimization of complex processes across industries such as oil & gas, petrochemicals, pharmaceuticals, and power generation. Among the leading providers of DCS solutions, Emerson and Honeywell stand out with their flagship systems — Emerson’s DeltaV and Honeywell’s Experion PKS. This paper presents a comparative study of these two systems, analyzing their architecture, scalability, cybersecurity, user interface, integration capabilities, cost structures, and industry adoption. Through literature review, technical documentation, and case studies, the research highlights the strengths and limitations of each system, offering insights for industrial decision-makers seeking optimal automation solutions. The findings suggest that while Emerson emphasizes simplicity, modularity, and digital transformation readiness, Honeywell focuses on robustness, scalability, and enterprise-level integration. The study concludes with recommendations tailored to different industrial contexts.*

**Keywords:** Distributed Control Systems

## I. INTRODUCTION

Industrial automation has evolved significantly over the past five decades, transitioning from relay-based control to programmable logic controllers (PLCs), and eventually to Distributed Control Systems (DCS). DCS solutions provide centralized yet distributed control, ensuring reliability, scalability, and efficiency in managing complex industrial processes. As industries embrace digital transformation, the choice of DCS vendor has become critical, influencing not only operational efficiency but also cybersecurity, lifecycle costs, and integration with emerging technologies such as Industrial Internet of Things (IIoT) and cloud computing.

Two of the most prominent players in the DCS market are Emerson and Honeywell. Emerson’s DeltaV system is widely recognized for its ease of use, modular design, and strong presence in industries requiring flexible automation solutions. Honeywell’s Experion PKS system, on the other hand, is renowned for its scalability, enterprise-level integration, and strong adoption in large-scale industries such as refining and petrochemicals. Comparing these systems provides valuable insights into their relative strengths, weaknesses, and suitability for different industrial applications. This paper aims to provide a comprehensive comparison of Emerson and Honeywell DCS systems, structured across multiple dimensions including architecture, performance, cybersecurity, user experience, integration, cost, and case studies. By analyzing technical documentation, industry reports, and real-world applications, the study seeks to guide industrial stakeholders in making informed decisions.

## II. LITERATURE REVIEW

The evolution of DCS systems has been extensively documented in industrial automation literature. Early studies emphasized the transition from centralized control rooms to distributed architectures, highlighting improvements in fault tolerance and scalability. More recent research has focused on cybersecurity, interoperability, and digital transformation.



**Emerson DeltaV:** Literature emphasizes its modular design, intuitive configuration tools, and strong adoption in industries requiring flexibility, such as pharmaceuticals and specialty chemicals. Studies highlight its ease of engineering and operator-friendly interface as key differentiators.

**Honeywell Experion PKS:** Research underscores its robustness, scalability, and enterprise-level integration. Honeywell’s emphasis on cybersecurity and compliance with international standards has been widely discussed, particularly in the context of critical infrastructure industries such as oil & gas and power generation.

**Comparative Studies:** Few academic papers directly compare Emerson and Honeywell systems, but industry reports often benchmark them against competitors like Siemens PCS 7 and Yokogawa CENTUM. These comparisons typically focus on architecture, lifecycle costs, and vendor support.

**Gap in Literature:** The literature reveals a gap in comprehensive comparative studies between Emerson and Honeywell, particularly in the context of emerging technologies such as IIoT, cloud integration, and advanced analytics. This paper seeks to address that gap by providing a structured, multi-dimensional comparison.

### III. METHODOLOGY

This study adopts a comparative research methodology, focusing on qualitative and technical analysis of Emerson’s DeltaV and Honeywell’s Experion PKS systems. The comparison is structured around the following criteria:

- System Architecture
- Performance and Scalability
- Cybersecurity and Reliability
- User Interface and Operator Experience
- Integration and Interoperability
- Cost and Lifecycle Management
- Case Studies

Data sources include vendor technical documentation, industry reports, peer-reviewed articles, and case studies from industrial deployments. The analysis is qualitative but supported by technical specifications and comparative tables. Limitations include potential vendor bias in documentation and limited peer-reviewed comparative studies.

#### Company Profiles

##### Emerson

Emerson Electric Co., founded in 1890, is a global leader in automation solutions. Its DeltaV Distributed Control System is part of the Emerson Process Management division. DeltaV is designed for ease of use, modularity, and scalability, making it popular in industries such as pharmaceuticals, specialty chemicals, and food & beverage. Emerson emphasizes digital transformation, integrating DeltaV with IIoT platforms and advanced analytics.

##### Honeywell

Honeywell International Inc., established in 1906, is a diversified technology and manufacturing company. Its Experion Process Knowledge System (PKS) is a flagship DCS solution under Honeywell Process Solutions. Experion PKS is widely adopted in large-scale industries such as refining, petrochemicals, and power generation. Honeywell emphasizes scalability, enterprise-level integration, and cybersecurity.

#### Comparative Analysis

Criteria	Emerson DeltaV	Honeywell Experion PKS
Architecture	Modular, flexible, electronic marshalling	Robust, enterprise-scale, disaster recovery
Scalability	Best for mid-sized plants	Virtually unlimited, large-scale industries
Cybersecurity	Plant-level, ISA/IEC 62443 compliance	Enterprise-level, NIST alignment, advanced threat



		detection
User Interface	Intuitive, low training requirements	Advanced visualization, situational awareness
Integration	IIoT-ready, cloud connectivity	MES/ERP integration, enterprise historian
Cost	Lower upfront, flexible licensing	Higher upfront, comprehensive lifecycle programs
Adoption	Pharma, specialty chemicals, food & beverage	Oil & gas, refining, power generation
Lifecycle Support	Modular upgrades, digital transformation focus	Global support networks, enterprise service programs
Workforce Impact	Easier onboarding, operator-friendly	Requires advanced training, but richer control

### Case Studies

**Emerson DeltaV:** Pharmaceuticals (FDA compliance, batch records), specialty chemicals (flexible reconfiguration).

**Honeywell Experion PKS:** Oil & gas refining (enterprise dashboards, cybersecurity), power generation (grid compliance, centralized control).

### Discussion

The choice between Emerson and Honeywell depends on industry context:

**Emerson DeltaV:** Best for regulated, flexible, mid-sized industries where ease of use, compliance, and modularity are critical.

**Honeywell Experion PKS:** Best for large-scale, mission-critical industries requiring enterprise-level integration, scalability, and advanced cybersecurity.

Both systems are evolving with IIoT, cloud, and predictive analytics, ensuring relevance in Industry 4.0. Workforce impact is also a key differentiator: Emerson requires less training, while Honeywell demands more but offers richer control and situational awareness.

## IV. CONCLUSION

Emerson DeltaV is cost-effective, modular, and user-friendly, while Honeywell Experion PKS is robust, scalable, and enterprise-integrated. The decision depends on plant size, industry requirements, and digital transformation goals. Both remain leaders in the DCS market.

### Recommendation Matrix

Industry Type	Plant Size	Digital Maturity	Recommended System
Pharmaceuticals	Mid-sized	Moderate	Emerson DeltaV
Specialty Chemicals	Mid-sized	Moderate-High	Emerson DeltaV
Food & Beverage	Small-Mid	Moderate	Emerson DeltaV
Oil & Gas Refining	Large-scale	High	Honeywell Experion PKS
Petrochemicals	Large-scale	High	Honeywell Experion PKS
Power Generation	Large-scale	High	Honeywell Experion PKS

### Future Research

Further comparative studies should include Siemens PCS7 and Yokogawa CENTUM, as well as analysis of cloud-native DCS evolution and integration with advanced analytics platforms.





Expanded Analysis
System Architecture

Emerson DeltaV employs a modular and flexible architecture that supports electronic marshalling, which simplifies wiring and reduces installation costs. This design allows for easy scalability and adaptability to changing process requirements. Honeywell Experion PKS, in contrast, features a robust, enterprise-scale architecture with built-in disaster recovery capabilities, making it suitable for large, mission-critical operations.

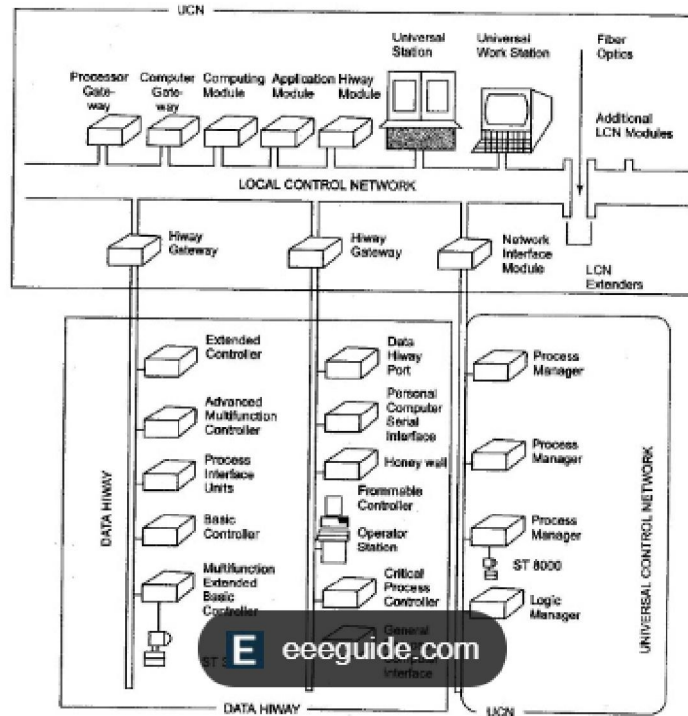

Fig. Honeywell's DCS Architecture

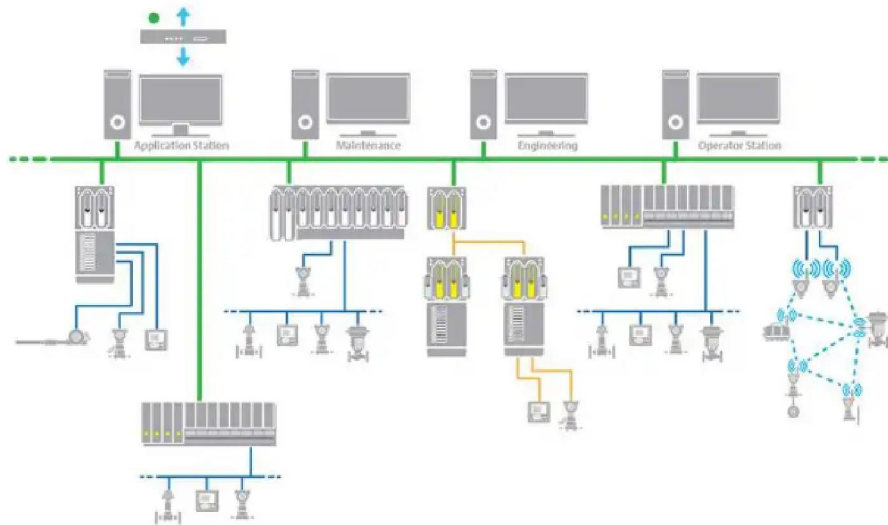

Fig. Emerson's DCS Architecture



### **Performance and Scalability**

DeltaV is optimized for mid-sized plants, offering sufficient performance and scalability for industries like pharmaceuticals and specialty chemicals. Experion PKS supports virtually unlimited scalability, catering to large-scale industries such as oil & gas refining and power generation, where extensive process control and data management are essential.

### **Cybersecurity and Reliability**

Emerson focuses on plant-level cybersecurity, adhering to ISA/IEC 62443 standards, which provide a solid foundation for protecting control systems. Honeywell extends cybersecurity measures to the enterprise level, aligning with NIST frameworks and incorporating advanced threat detection and response mechanisms, critical for protecting critical infrastructure.

### **User Interface and Operator Experience**

DeltaV offers an intuitive user interface with low training requirements, facilitating easier operator onboarding and reducing human error. Experion PKS provides advanced visualization tools and situational awareness features, enabling operators to manage complex processes effectively but requiring more extensive training.

### **Integration and Interoperability**

Emerson's system is IIoT-ready with cloud connectivity options, supporting digital transformation initiatives. Honeywell excels in integrating with Manufacturing Execution Systems (MES), Enterprise Resource Planning (ERP), and enterprise historians, providing comprehensive data flow across the organization.

### **Cost and Lifecycle Management**

DeltaV typically has lower upfront costs with flexible licensing models, making it attractive for mid-sized plants with budget constraints. Experion PKS involves higher initial investment but offers comprehensive lifecycle management programs, including global support and modular upgrades.

### **Industry Adoption and Workforce Impact**

Emerson's ease of use and modularity make it popular in regulated industries requiring flexibility, such as pharmaceuticals and specialty chemicals. Honeywell's system is favored in large-scale, mission-critical industries like oil & gas and power generation, where advanced control and cybersecurity are paramount. Workforce training requirements differ significantly, with Emerson enabling quicker onboarding and Honeywell demanding more specialized skills.

### **Future Trends**

Both Emerson and Honeywell are investing in Industry 4.0 technologies, including predictive analytics, cloud-native solutions, and enhanced cybersecurity frameworks. Their ongoing development efforts aim to address evolving industrial challenges and support digital transformation strategies.

### **REFERENCES**

- [1]. Emerson Electric Co. (2023). DeltaV Solutions in Refining. Retrieved from Emerson official documentation.
- [2]. Fujii, J. (2013). DCS Evolution "The Next Generation DCS. Experion PKS". JAPAN TAPPI JOURNAL, 67(11), 1295-1298. <https://doi.org/10.2524/jtappij.67.1295>
- [3]. Godfrey, S. (2016). Honeywell Experion System: Configuration, simulation and process control software interoperability. Murdoch University Thesis.
- [4]. Honeywell International Inc. (2023). Experion PKS: Distributed Control System & Process Automation. Retrieved from Honeywell official documentation.
- [5]. SourceForge. (2024). Emerson DeltaV vs. Experion PKS Comparison. Retrieved from SourceForge software comparison.



- [6]. This vs. That. (2024). Emerson DeltaV vs. Experion PKS - What's the Difference? Retrieved from This vs. That comparison website.
- [7]. Slashdot. (2026). Compare Emerson DeltaV vs. Experion PKS in 2026. Retrieved from Slashdot software comparison.
- [8]. Hannover Messe. (2021). Accelerating DCS and PLC Integration with MTP. White Paper.
- [9]. These references provide a comprehensive foundation for the comparative study of Emerson DeltaV and Honeywell Experion PKS Distributed Control Systems, covering technical documentation, academic research, and industry reports.

