

Optimization of Auto Start-Stop System for Sustainable Driving

Harshvardhan Bhosale¹, Avadhut Bhosale², Rohit Kalugade³, Sneha Gholap⁴,
Dahi Pakjade⁵, Mr. P. G. Patil⁶

Students, Department of Electrical Engineering¹⁻⁵

Guide, Department of Electrical Engineering⁶

Rajarambapu Institute of Technology, Rajaramnagar, Maharashtra, India

Abstract: *The rapid urbanization of the 21st century has led to a significant increase in vehicle idling time, contributing to excessive fuel consumption and environmental degradation. While conventional Auto Start-Stop (ASS) systems exist, they are primarily reactive, leading to issues such as premature battery degradation, starter motor wear, and driver discomfort due to "micro-stops." This paper presents an optimized approach to the ASS system through a multifaceted solution: the integration of predictive logic via V2X (Vehicle-to-Everything) data, the implementation of supercapacitor buffers to alleviate electrical strain on batteries, and the use of electric auxiliary oil pumps to maintain lubrication. A hardware prototype utilizing an Arduino-based controller and DC motor simulation was developed to validate the proposed logic. Preliminary findings suggest that this optimization can significantly reduce unnecessary engine restarts, maintain mechanical integrity, and improve the overall sustainability of urban transportation.*

Keywords: *Auto Start-Stop*

I. INTRODUCTION

In modern urban environments, idling is a major contributor to global carbon emissions. Statistics indicate that the average urban driver spends approximately 100 hours per year idling in traffic, which equates to millions of tons of avoidable greenhouse gas emissions and significant economic loss in wasted fuel. The Auto Start-Stop system was introduced as a solution to shut down the Internal Combustion Engine (ICE) during stops. However, current systems are "reactive"—they only respond to the current state of the vehicle (e.g., brake pedal position) without considering the surrounding traffic context. This results in "hunting" or frequent, unnecessary restarts during bumper-to-bumper traffic. This paper explores an optimized, "proactive" system designed to bridge the gap between environmental efficiency and mechanical durability.

II. LITERATURE REVIEW

Current automotive research focuses heavily on improving battery chemistry (e.g., EFB and AGM batteries) to handle the increased load of start-stop cycles. However, there is a lack of integrated solutions that combine electrical buffering with predictive environmental data. Most existing literature treats the ASS system as a standalone mechanical function. There is a clear gap in research regarding the use of supercapacitors as a dedicated cranking power source in conjunction with the main battery, and the use of external data (V2I) to prevent "micro-stop" triggers. This paper aims to fill this gap by proposing a holistic optimization of the control logic and hardware architecture.

III. PROBLEM STATEMENT

Existing Auto Start-Stop systems face a "trilemma" of mechanical, electrical, and ergonomic challenges:



Mechanical Stress: Frequent restarts lead to accelerated wear on the starter motor and ring gears. More critically, when the engine stops, the mechanical oil pump ceases, leading to a loss of oil pressure that can cause "dry starts" and damage turbochargers or bearings.

Electrical Strain: Traditional LeadAcid or even AGM batteries face highcurrent "hits" during every restart, leading to a shorter lifecycle and potential failure of sensitive onboard electronics.

User Frustration: Reactive systems often trigger during 1–2 second stops (inching forward), causing engine shudder and a dangerous lag when the driver needs to accelerate quickly into traffic, leading many users to permanently disable the feature.

IV. PROPOSED Solution (Auto start stop system): Step 1

The proposed system optimizes the ASS through three primary innovations:

Predictive Intelligence: By utilizing sensors or V2I data, the system distinguishes between a “short-duration stop” (inching) and a “long-duration stop” (red light). The engine only shuts down when a significant idle period is predicted.

Electrical Buffering (Supercapacitors): A supercapacitor bank is used to handle the high-current surge required for cranking. This protects the primary battery from voltage dips and extends its operational life.

Auxiliary Lubrication: The integration of an electric auxiliary oil pump ensures that oil pressure is maintained in the engine galleries even when the crankshaft is stationary, eliminating the risk of dry starts.

Block diagram:

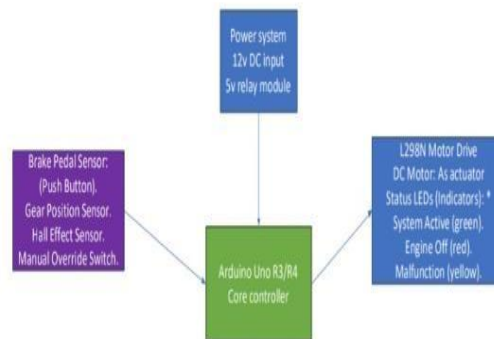

Constructed Block diagram of Simulation model of Auto Start-Stop System

V. METHODOLOGY

WORKING PRINCIPLE

The system operates on a sense-process actuate loop:

Sensing Stage: The microcontroller continuously monitors the Brake Pedal (Input 1), Gear Status (Input 2), and Wheel Speed via Hall Effect sensors.

Logic Processing: If the vehicle speed is zero and the brake is depressed, the system checks the "Predictive Timer." If the stop is projected to be longer than 5 seconds, it sends a signal to cut fuel/spark simulation.

Actuation Stage: The L298N driver stops the DC motor. Simultaneously, the auxiliary oil pump is activated.

4. **Restart Stage:** Upon brake release, the supercapacitor discharges into the starter simulation (DC motor) for an instantaneous start, returning control to the driver with minimal vibration.



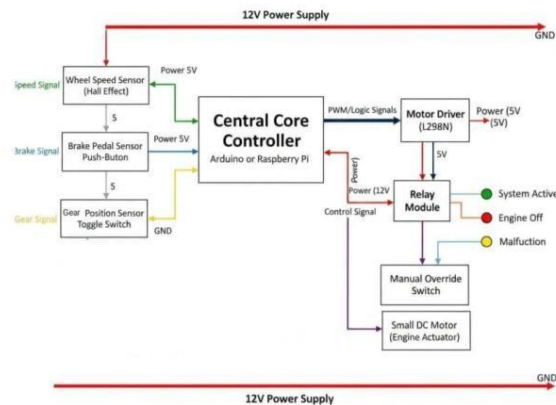

Result:

Technical Reliability: To demonstrate a prototype that eliminates the “lag” associated with conventional start-stop systems.

Mechanical Protection: To maintain constant oil pressure during the “off” state to prevent engine wear.

Energy Efficiency: To reduce fuel consumption during the restart phase by 3–5% through refined timing and reduced cranking duration.

Scalability: To design a logic controller that can be integrated into existing Vehicle ECUs (Electronic Control Units) with minimal hardware modification.

VI. ADVANTAGES

Component Longevity: Significant reduction in battery and starter motor replacement frequency.

Sustainable Driving: Encourages higher adoption of the ASS system by making it less intrusive for the driver.

Environmental Compliance: Helps manufacturers meet stricter Euro 6/BSVI emission norms by reducing cold-start-like conditions and idling emissions.

Safety: Zero-lag restarts ensure that the vehicle is ready to move the moment traffic clears.

APPLICATIONS

The modular nature of this control logic allows for widespread application:

Entry-Level Passenger Vehicles: Providing high-end predictive tech to budget-friendly petrol cars.

Heavy Logistics: Reducing fuel costs for diesel trucks that spend hours at toll booths and loading docks.

Two-Wheeler Segment: Implementing "Smart-Start" controllers in scooters and commuter motorcycles to improve fuel economy in dense urban traffic.

Retrofitting: Potential for aftermarket modules to upgrade older vehicles with modern startstop efficiency.

