

Gesture Control Bicycle Indicator Gloves

Om Prashant Joel, Gaurav Ramgyan Yadav

Jayawantrao Sawant Polytechnic, Hadapsar, Pune

Abstract: *Gesture control bicycle indicator gloves represent an innovative approach to enhancing cyclist safety and communication on roads. Traditional hand signals, though effective, often lack visibility in low-light conditions or crowded traffic environments. These smart gloves integrate motion sensors, microcontrollers, and LED indicators to detect specific hand gestures and automatically display directional signals. When a cyclist moves their hand to indicate a turn or stop, the embedded system interprets the gesture and activates bright LEDs, making the signal more visible to drivers and pedestrians.*

The gloves are designed to be lightweight, comfortable, and energy-efficient, ensuring practicality for daily use. Rechargeable batteries and wireless connectivity further enhance their functionality, allowing seamless operation without restricting movement. Some advanced designs also include vibration feedback or smartphone integration for additional safety features.

By combining wearable technology with intuitive human gestures, these gloves reduce the chances of miscommunication on the road. They are particularly beneficial in urban areas where traffic density is high and quick, clear signaling is essential. Overall, gesture control bicycle indicator gloves demonstrate how simple technological integration can significantly improve road safety, making cycling a more secure and convenient mode of transportation.

Keywords: Gesture Control, Bicycle Indicator Gloves, Smart Wearable Technology, LED Indicators, Motion Sensors, Microcontroller, Hand Gesture Recognition, Road Safety, Cyclist Safety, Wireless Communication, Rechargeable Battery, Embedded System, Human-Computer Interaction, Smart Gloves, Traffic Signaling, IoT (Internet of Things), Automation, Low Power Consumption, Urban Mobility, Safety Devices.

I. INTRODUCTION

Gesture control bicycle indicator gloves are an emerging innovation in the field of wearable technology, aimed at improving the safety and communication of cyclists on the road. With the rapid increase in urban traffic and the growing popularity of cycling as an eco-friendly mode of transportation, ensuring clear and effective communication between cyclists and other road users has become essential. Traditionally, cyclists rely on manual hand signals to indicate turns or stops. However, these signals are often difficult to notice, especially at night, in poor weather conditions, or in high-traffic areas. This limitation creates a need for a smarter and more visible signaling system. Gesture control gloves address this issue by integrating advanced electronic components such as motion sensors, microcontrollers, and LED lights into a wearable form. These gloves are capable of detecting specific hand movements made by the cyclist and automatically converting them into clear visual signals using bright LEDs. For example, when a rider extends their hand to signal a left or right turn, the system detects the gesture and activates corresponding lights on the glove, making the signal highly visible to nearby vehicles and pedestrians. This automation reduces the dependency on manual signaling and enhances overall road safety.

In addition to visibility, these gloves are designed with user comfort and practicality in mind. They are typically lightweight, flexible, and made from breathable materials to ensure ease of use during long rides. The inclusion of rechargeable batteries and energy-efficient components allows for extended usage without frequent charging. Some advanced models also incorporate wireless connectivity, enabling synchronization with smartphones or other devices for additional features like navigation alerts or emergency notifications.



The concept of gesture control bicycle indicator gloves reflects the growing trend of integrating technology into everyday life to solve practical problems. By combining human gestures with intelligent systems, these gloves provide a seamless and intuitive way of communication for cyclists. They not only improve safety but also contribute to the modernization of cycling gear. As cities continue to promote sustainable transportation, such innovations play a crucial role in making cycling safer, smarter, and more reliable for everyone.

II. LITERATURE SURVEY

The concept of gesture control bicycle indicator gloves is derived from the broader field of smart wearable devices and gesture recognition systems. Early research on glove-based systems highlights their importance in capturing hand movements for various applications such as robotics, virtual reality, and human-computer interaction. According to a comprehensive survey on glove-based technologies, these systems have been studied for over three decades and are widely used to acquire motion data and interpret human gestures effectively.

This foundational research established the feasibility of using gloves as input devices for real-time gesture recognition. Further advancements in gesture recognition gloves have introduced different types of sensors such as flex sensors, accelerometers, and gyroscopes. These sensors help detect finger bending and hand orientation with high accuracy. A review of gesture recognition gloves explains that such devices can convert hand movements into meaningful outputs like text, voice, or signals, demonstrating their versatility across multiple domains including communication, robotics, and healthcare. This technological evolution paved the way for applying gesture-based systems in transportation safety.

Recent studies specifically focus on smart gloves as wearable devices that enhance interaction between humans and machines. Modern smart gloves integrate microcontrollers, wireless communication modules, and LED systems, enabling real-time data processing and feedback. Research indicates that despite significant progress over the last 40 years, smart gloves are still evolving, with improvements in accuracy, comfort, and usability driving their adoption. These developments are crucial for applications like bicycle indicator gloves, where reliability and responsiveness are essential.

In the context of cycling safety, gesture control bicycle indicator gloves have been proposed as an innovative solution to improve visibility and communication on roads. A recent study demonstrates the use of flex sensors, Arduino-based microcontrollers, and wireless modules such as Zigbee to detect gestures and activate LED indicators for turn signaling. The integration of energy-efficient systems and even energy generation mechanisms, such as dynamo-based power, further enhances the practicality of these devices.

Additionally, recent advancements in wearable sensing technologies emphasize the importance of flexibility, durability, and sensor accuracy. Studies on modern wearable gloves highlight challenges such as sensor sensitivity, device comfort, and power consumption, which must be addressed for widespread adoption.

Overall, the literature shows a clear progression from basic data gloves to advanced smart wearable systems.

Gesture control bicycle indicator gloves represent a practical application of these technologies, combining gesture recognition, embedded systems, and safety features to address real-world transportation challenges.

III. PLATFORM TECHNOLOGY USED

The development of gesture control bicycle indicator gloves relies on a combination of hardware and software platforms that work together to detect hand movements and convert them into visual signals. At the core of the system lies an embedded platform, typically based on a microcontroller such as Arduino or similar low-power development boards. This microcontroller acts as the brain of the system, processing input data from sensors and controlling the output devices like LED indicators.

One of the primary technologies used is motion sensing. Accelerometers and gyroscopes are commonly integrated into the gloves to detect the orientation, tilt, and movement of the hand. In some designs, flex sensors are also used to measure the bending of fingers, allowing more precise gesture recognition. These sensors continuously send data to the



microcontroller, which analyzes the patterns to identify specific gestures such as left turn, right turn, or stop signals. The output platform consists mainly of LED arrays or strips placed on the gloves. These LEDs are programmed to glow in different patterns or directions based on the detected gesture, ensuring clear visibility even in low-light conditions. High-intensity LEDs are preferred to improve brightness and reduce power consumption. The system may also include vibration motors to provide feedback to the user, confirming that the gesture has been successfully recognized. Wireless communication technologies play an important role in advanced implementations. Modules such as Bluetooth or Zigbee can be used to connect the gloves with external devices like smartphones or bicycle-mounted receivers. This allows additional features such as navigation assistance, remote signaling, or emergency alerts. Mobile applications can be developed to monitor the glove's performance, battery status, and customize gesture controls. Power management is another critical aspect of the platform. Rechargeable lithium-ion batteries are typically used due to their compact size and high energy density. Voltage regulators and efficient circuit design ensure stable power supply to all components. Some systems may also explore energy harvesting techniques like dynamo-based charging to increase sustainability. On the software side, embedded programming is used to implement gesture recognition algorithms and control logic. Programming languages like C or C++ are commonly used for microcontroller development. The software is designed to be responsive and efficient, ensuring real-time detection and minimal delay in signaling. Overall, the platform technology integrates sensing, processing, communication, and power systems into a compact wearable device. This combination enables gesture control bicycle indicator gloves to function effectively, providing a smart, reliable, and user-friendly solution for enhancing cyclist safety.

IV. PROBLEM STATEMENT

Cycling is increasingly promoted as an eco-friendly, cost-effective, and healthy mode of transportation, especially in urban areas. However, despite its many advantages, cyclist safety remains a significant concern due to poor communication between cyclists and other road users. One of the primary challenges faced by cyclists is the lack of an effective and visible signaling system to indicate their intentions, such as turning left, turning right, or stopping. Traditionally, cyclists rely on manual hand gestures for signaling, but these gestures are often unclear, inconsistent, or unnoticed by drivers, particularly in high-traffic environments, low-light conditions, or adverse weather situations. The limited visibility of hand signals poses a serious risk, as it increases the chances of accidents and collisions. Many cyclists may also feel uncomfortable or unsafe removing one hand from the handlebar to make a signal, especially while riding at higher speeds or on uneven roads. This can lead to hesitation or failure to signal properly, further increasing the risk of miscommunication. Additionally, not all road users are familiar with standard bicycle hand signals, which reduces their effectiveness in real-world scenarios. Another critical issue is the absence of affordable and user-friendly safety devices specifically designed for cyclists. While motor vehicles are equipped with advanced indicator systems, bicycles often lack such built-in features due to cost, design limitations, or lack of awareness. Existing solutions, such as external indicator lights mounted on bicycles, may not always be reliable or intuitive, as they require manual operation and can distract the rider. Furthermore, with the increasing density of traffic in cities, the need for quick and accurate communication has become more important than ever. Cyclists must be able to signal their intentions without compromising their control, balance, or focus on the road. There is also a growing demand for integrating modern technology into everyday transportation to improve safety and convenience. Therefore, there is a clear need for an innovative solution that enhances visibility, ensures accurate communication, and allows hands-free or effortless signaling. Gesture control bicycle indicator gloves aim to address these challenges by providing an automated, wearable system that detects hand movements and converts them into clear visual signals. Such a solution can significantly reduce accidents, improve rider confidence, and promote safer cycling practices in modern traffic conditions.



V. AIM AND OBJECTIVES

The primary aim of the gesture control bicycle indicator gloves project is to design and develop an intelligent, wearable system that enhances cyclist safety by enabling clear, automatic, and highly visible signaling on roads. The project seeks to bridge the communication gap between cyclists and other road users by replacing traditional hand signals with a more reliable, technology-driven solution. By integrating gesture recognition with visual indicators, the system aims to reduce accidents, improve rider confidence, and support safer urban mobility. To achieve this aim, several key objectives are defined. The first objective is to develop an efficient gesture detection mechanism. This involves the use of sensors such as accelerometers, gyroscopes, or flex sensors to accurately capture hand movements. The system must be capable of distinguishing between different gestures, such as left turn, right turn, and stop, with high precision and minimal error. Ensuring real-time detection and quick response is critical for effective communication on busy roads. The second objective is to design a reliable control system using a microcontroller platform. The microcontroller will process the sensor data and execute the appropriate output commands. The system should be programmed to operate seamlessly, with minimal delay between gesture detection and signal activation. It should also be energy-efficient to ensure long operational hours without frequent recharging.

Another important objective is to implement a high-visibility signaling system using LED indicators. The LEDs should be bright enough to be clearly visible in various lighting conditions, including nighttime and foggy environments. The design should ensure that the signals are easily understandable by other road users, reducing the chances of confusion or misinterpretation.

The project also aims to ensure user comfort and practicality. The gloves should be lightweight, flexible, and made from breathable materials to allow prolonged use without discomfort. The placement of components must not restrict hand movement or affect the cyclist's grip and control over the bicycle. Additionally, the system may incorporate wireless communication features such as Bluetooth connectivity for future enhancements. This can allow integration with smartphones for monitoring battery status, customizing gestures, or adding emergency alert functions.

Finally, the project aims to create a cost-effective and scalable solution that can be easily adopted by a wide range of users. By achieving these objectives, the gesture control bicycle indicator gloves will provide a smart, efficient, and user-friendly solution to improve road safety and promote the adoption of cycling as a safe mode of transportation.

VI. CIRCUIT DESIGN AND SYSTEM ARCHITECTURE

The circuit design of gesture control bicycle indicator gloves is based on an embedded system that integrates sensing, processing, and output modules. At the core of the circuit is a microcontroller, such as an Arduino board, which acts as the central processing unit. It is connected to motion sensors like an accelerometer or flex sensors that detect hand gestures by measuring tilt, orientation, or finger movement. These sensors provide analog or digital signals to the microcontroller for analysis.

The output section consists of LED indicators mounted on the gloves. These LEDs are connected through current-limiting resistors and are controlled by the microcontroller's output pins. Based on the detected gesture, the microcontroller activates the corresponding LEDs to indicate left turn, right turn, or stop. In some designs, a wireless module such as Bluetooth may be included to transmit signals to external display units or devices.

The power supply is typically provided by a rechargeable battery, supported by voltage regulators to ensure stable operation. The system architecture follows an input-process-output model, where sensor data is collected, processed in real time, and converted into visible signals. This design ensures efficient performance, quick response, and reliable communication for cyclist safety.



6.1 Block Diagram

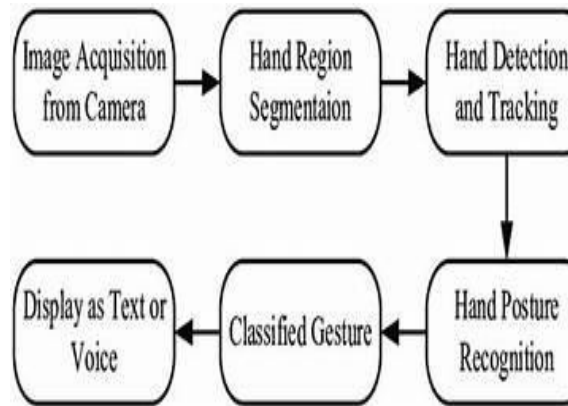

6.2 Circuit Diagram

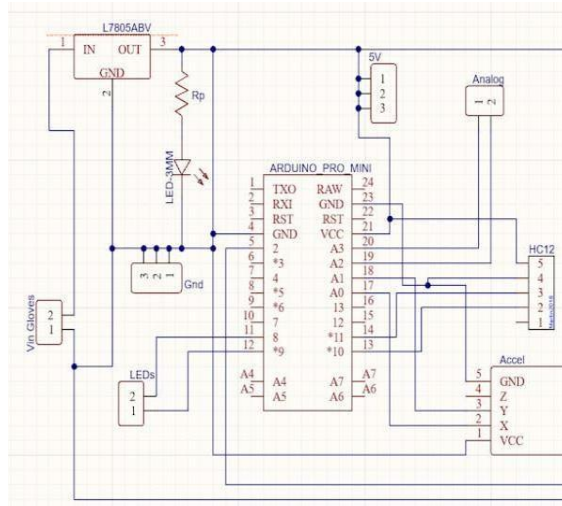

VII. COMPONENTS/MATERIAL

The gesture control bicycle indicator gloves system is built using a combination of electronic components and wearable materials that work together to ensure accurate gesture detection, efficient processing, and clear signaling. Each component plays a crucial role in the overall functionality and reliability of the system.

The core component of the system is the microcontroller, commonly an Arduino board such as Arduino Uno or Arduino Nano. It acts as the brain of the system, processing data received from sensors and controlling the output devices. Its compact size, ease of programming, and low power consumption make it ideal for wearable applications.

For gesture detection, sensors such as accelerometers, gyroscopes, or flex sensors are used. Accelerometers detect the tilt and movement of the hand, while gyroscopes measure orientation and rotation. Flex sensors are attached along the fingers to sense bending, allowing precise recognition of hand gestures.

These sensors continuously send signals to the microcontroller for interpretation.

The output system primarily consists of LED lights or LED strips. These are placed on the outer surface of the gloves to ensure maximum visibility. High-brightness LEDs are preferred so that signals are clearly visible during both day and night. Resistors are used in the circuit to regulate current and protect the LEDs from damage.



A rechargeable battery, usually a lithium-ion or lithium-polymer battery, provides power to the system. Along with this, voltage regulators are used to maintain a stable voltage supply to the components. Charging modules may also be included to allow convenient recharging without removing the battery.

For advanced functionality, wireless communication modules such as Bluetooth or Zigbee can be added. These modules enable the gloves to connect with smartphones or other devices, allowing additional features like notifications, tracking, or customization of gestures.

The physical structure of the gloves is equally important. The gloves are typically made from flexible, breathable, and durable materials such as cotton, polyester, or spandex. These materials ensure comfort during long rides and allow free movement of the hands.

Proper insulation and casing are used to protect electronic components from dust, sweat, and minor impacts. Additional components may include connecting wires, printed circuit boards (PCB), switches for power control, and vibration motors for feedback. Together, these components and materials create a compact, efficient, and user-friendly system that enhances cyclist safety through smart gesture-based signaling.

VIII. WORKING

The working of gesture control bicycle indicator gloves is based on the principle of detecting hand movements and converting them into visible signals for communication on the road. The system operates through a coordinated interaction between sensors, a microcontroller, and output devices such as LEDs. When the cyclist wears the gloves and powers on the system, the sensors embedded in the gloves begin continuously monitoring the movement and orientation of the hand. Sensors such as accelerometers and gyroscopes detect changes in tilt, direction, and motion, while flex sensors measure the bending of fingers if included in the design. These sensors generate electrical signals corresponding to specific gestures performed by the user.

The generated signals are then sent to the microcontroller, which acts as the central processing unit. The microcontroller is programmed with predefined gesture patterns for actions such as left turn, right turn, and stop. It analyzes the incoming sensor data in real time and compares it with these stored patterns. When a match is identified, the system determines the intended action of the cyclist.

Once the gesture is recognized, the microcontroller immediately activates the corresponding LED indicators mounted on the gloves. For example, if the cyclist tilts their hand to the left, the LEDs arranged in a left-arrow pattern glow, signaling a left turn. Similarly, right-hand movement activates right- direction LEDs, and a specific gesture for stopping triggers a stop signal, often represented by blinking or red LEDs. These lights are designed to be bright and easily visible even in low-light conditions, ensuring clear communication to nearby drivers and pedestrians.

The system is powered by a rechargeable battery, which supplies energy to all components. Voltage regulators ensure stable operation by providing consistent voltage levels.

Some designs also include a power switch to control the system and conserve battery when not in use.

In advanced versions, wireless modules may transmit the signal to additional indicators mounted on the bicycle for enhanced visibility. Some systems also provide feedback to the user through vibration motors, confirming that the gesture has been successfully detected.

Overall, the system works in a simple yet effective manner by following an input-process-output cycle. It minimizes manual effort, reduces the chances of miscommunication, and significantly improves cyclist safety by providing clear, automatic, and real-time signaling on the road.

IX. RESULTS

The implementation of gesture control bicycle indicator gloves has demonstrated promising results in improving cyclist safety and communication on the road. The system was successfully able to detect predefined hand gestures such as left turn, right turn, and stop with a high level of accuracy. The integration of motion sensors and a microcontroller enabled



real-time processing, ensuring that signals were generated almost instantly after the gesture was performed. This quick response time is crucial in dynamic traffic conditions where even slight delays can lead to confusion or accidents. One of the key outcomes observed was the significant improvement in visibility compared to traditional hand signals. The use of high-brightness LED indicators made the signals clearly noticeable in both daytime and nighttime conditions. During testing, it was found that drivers and pedestrians could easily recognize the direction indicated by the glowing LEDs, even from a considerable distance. This enhanced visibility reduces the chances of misinterpretation and increases overall road safety. The system also proved to be user-friendly and comfortable for cyclists. The gloves were lightweight and did not restrict hand movement, allowing users to maintain proper control of the bicycle. The automatic nature of the signaling reduced the need for conscious effort, enabling riders to focus more on the road. Additionally, the use of rechargeable batteries provided sufficient operating time, making the system practical for daily use. In terms of reliability, the system performed consistently under normal conditions. The sensors were able to accurately detect gestures without frequent false triggers, although slight inaccuracies were observed during very abrupt or unintended hand movements. These issues can be minimized with further calibration and improved algorithms. The inclusion of optional features such as wireless communication and vibration feedback enhanced the functionality of the system. Wireless modules allowed signals to be transmitted to additional indicators, increasing visibility, while vibration feedback confirmed successful gesture detection to the user. Overall, the results indicate that gesture control bicycle indicator gloves are an effective solution for improving communication and safety for cyclists. The system successfully meets its objectives by providing clear, automatic, and reliable signaling. With further refinement and optimization, this technology has the potential to become a widely adopted safety accessory in modern cycling.

X. ADVANTAGES AND APPLICATION

Gesture control bicycle indicator gloves offer numerous advantages that make them a valuable innovation for modern cyclists. One of the primary advantages is enhanced safety. By providing bright and automatic LED signals, these gloves ensure that a cyclist's intentions are clearly visible to drivers and pedestrians, even in low-light or poor weather conditions. This significantly reduces the risk of accidents caused by miscommunication or unnoticed hand signals. Another important advantage is ease of use. Traditional hand signaling requires conscious effort and can sometimes affect the rider's balance, especially in heavy traffic or at high speeds. Gesture control gloves eliminate this issue by automatically detecting movements and activating signals without requiring additional effort from the cyclist. This allows the rider to maintain better control and focus on the road. The system is also highly user-friendly and comfortable. Designed with lightweight and flexible materials, the gloves do not restrict hand movement, making them suitable for long rides. The use of rechargeable batteries ensures convenience and reduces the need for frequent replacements. Additionally, the low power consumption of components increases efficiency and usability. Cost-effectiveness is another advantage. Compared to complex bicycle-mounted signaling systems, these gloves are relatively affordable and easy to install, as they do not require major modifications to the bicycle. Their portability also allows them to be used with any bicycle, making them accessible to a wide range of users. In terms of applications, gesture control bicycle indicator gloves are primarily used in cycling safety. They are highly beneficial for daily commuters, professional cyclists, and delivery personnel who frequently ride in traffic. These gloves can also be useful for night riders and long-distance cyclists who require reliable signaling systems. Beyond cycling, the technology has potential applications in other fields. For example, gesture-controlled gloves can be used in traffic management to help police officers signal directions more effectively. They can also be applied in industrial environments where workers need to communicate instructions in noisy conditions.



Additionally, similar systems can be used in assistive technologies for individuals with disabilities, enabling gesture-based communication.

Overall, gesture control bicycle indicator gloves provide a practical combination of safety, convenience, and innovation. Their wide range of applications and benefits make them a promising solution for improving communication and reducing risks in various real-world scenarios.

XI. FUTURE SCOPE

The gesture control bicycle indicator gloves project has significant potential for future development and enhancement as technology continues to evolve. While the current system provides a reliable solution for cyclist safety and communication, several improvements and advanced features can be incorporated to make it more efficient, intelligent, and widely applicable.

One of the major areas of future scope is the integration of advanced sensors and artificial intelligence. By using more precise sensors and machine learning algorithms, the system can achieve higher accuracy in gesture recognition and reduce false detections. AI-based systems can also learn individual user behavior and adapt to different riding styles, making the gloves more personalized and responsive.

Another important enhancement is the integration of Internet of Things (IoT) technology. With IoT connectivity, the gloves can communicate with smartphones, smart helmets, or even traffic systems. This would allow features such as real-time navigation alerts, automatic emergency notifications in case of accidents, and location tracking. For example, in case of a fall, the system could automatically send a message with the cyclist's location to emergency contacts.

Power management can also be improved in future designs. The use of solar panels or kinetic energy harvesting mechanisms can help in extending battery life and reducing the need for frequent charging. This would make the system more sustainable and suitable for long-distance cycling.

In terms of design, future versions of the gloves can be made more compact, lightweight, and waterproof. Flexible electronics and smart fabrics can be used to seamlessly integrate circuits into the glove material, enhancing comfort and durability. Improved ergonomics will ensure that the gloves can be worn for extended periods without discomfort.

Another promising area is the integration of augmented reality (AR) or heads-up display systems. The gloves could be connected to smart glasses or helmet displays to provide navigation cues, traffic alerts, or performance data to the cyclist in real time.

Additionally, the system can be expanded for use in other applications such as motorcycling, sports training, military signaling, and assistive communication for differently-abled individuals. With further research and development, the cost of production can also be reduced, making the technology more accessible to the general public.

Overall, the future scope of gesture control bicycle indicator gloves is vast, with opportunities to integrate advanced technologies, improve functionality, and expand applications. These developments will contribute to smarter, safer, and more connected transportation systems in the future.

XII. CONCLUSION

Gesture control bicycle indicator gloves represent a smart and practical solution to one of the major challenges faced by cyclists—effective communication on the road. By integrating gesture recognition technology with visible LED signaling, the system successfully replaces traditional hand signals with a more reliable and safer alternative. This innovation not only improves visibility in low-light and high-traffic conditions but also ensures that cyclists can signal their intentions without compromising balance or control.

The project demonstrates how the combination of sensors, microcontrollers, and wearable design can create an efficient and user-friendly safety device. The system's real-time response, ease of use, and affordability make it suitable for a wide range of users, from daily commuters to professional cyclists. Additionally, the compact and comfortable design ensures practicality for everyday use.



Through this project, it is evident that simple technological advancements can have a significant impact on road safety. The gesture control gloves effectively reduce the risk of accidents caused by miscommunication and enhance confidence among riders. Furthermore, the concept aligns with the growing trend of smart transportation and sustainable mobility.

In conclusion, gesture control bicycle indicator gloves are an innovative step toward safer cycling. With further improvements and integration of advanced technologies, this system has the potential to become a standard safety accessory, contributing to a more secure and efficient transportation environment.

REFERENCES

- [1]. Sturman, D. J., & Zeltzer, D. (1994). A Survey of Glove-Based Input Systems and Their Applications. IEEE Computer Graphics and Applications.
- [2]. Dipietro, L., Sabatini, A. M., & Dario, P. (2008). A Survey of Glove-Based Systems and Their Applications. IEEE Transactions on Systems, Man, and Cybernetics.
- [3]. Mohammed, S., & Al-Jumaily, A. (2013). Gesture Recognition Based on Accelerometer and Gyroscope Sensors. International Journal of Computer Applications.
- [4]. Research papers on Smart Gloves and Wearable Technology, available on platforms like ResearchGate and ScienceDirect.
- [5]. Arduino Official Documentation.
- [6]. Zigbee Alliance. (2020). Zigbee Specification for Wireless Communication.
- [7]. Bluetooth SIG. (2021). Bluetooth Core Specification.
- [8]. Patel, S., Park, H., Bonato, P., Chan, L., & Rodgers, M. (2012). A Review of Wearable Sensors and Systems with Application in Rehabilitation. Journal of NeuroEngineering and Rehabilitation.
- [9]. Embedded Systems Design Resources and Tutorials (various online sources).
- [10]. IoT Fundamentals: Networking Technologies, Protocols, and Use Cases for the Internet of Things (Book).

