

# Smart Pill Dispenser Robot

<sup>1</sup>Prof. Mandhare S. V. , <sup>2</sup>Prashant Shivaji Galande, <sup>3</sup>Samruddhi Ravindra Sutar,  
<sup>4</sup>Ritesh Umesh Wandhekar, <sup>5</sup>Priyanka Haribhau Pawar.

<sup>1</sup>Assistant Professor, Department of Electronic and Telecommunications Engineering

<sup>2,3,4,5</sup>Students, Department of Electronic and Telecommunications Engineering

Ashok Institute of Engineering & Technology Polytechnic College, Shirampur.

**Abstract:** *The Smart Pill Dispenser Robot is an automated healthcare system designed to ensure timely and accurate medication intake for patients. In today's fast-paced lifestyle, many individuals, especially elderly people and patients with chronic illnesses, often forget to take their medicines on time. This project aims to solve this problem by developing a smart, reliable, and user-friendly medicine dispensing system.*

*The system is built using the ESP8266 microcontroller, which controls the overall operation of the device. A 16×2 LCD display is used to show important information such as current time, medicine schedule, and alert messages. A real-time clock mechanism is used to track time and trigger the system at predefined intervals. When the scheduled time matches, the system activates a servo motor that rotates to dispense the required medicine dose. At the same time, a notification is displayed on the LCD to alert the user.*

*A manual push button is incorporated into the system to provide user control for setting time, changing schedules, and acknowledging alerts. This makes the system simple and easy to operate without requiring advanced technical knowledge. The design focuses on accuracy, reliability, and ease of use.*

*The proposed system reduces human error, improves medication adherence, and enhances patient care. It is particularly useful for elderly individuals, busy professionals, and patients who require regular medication. The system can be further upgraded with Internet of Things (IoT) features for remote monitoring and control.*

*In conclusion, the Smart Pill Dispenser Robot provides an efficient and practical solution to manage daily medication, contributing to better health management and improved quality of life.*

**Keywords:** *ESP8266 microcontroller*

## I. INTRODUCTION

### 1.1 Overview of Smart Pill Dispenser System

The Smart Pill Dispenser Robot is an automated healthcare device designed to ensure that patients take their medications on time without missing any doses. In modern life, people often forget to take medicines due to busy schedules, stress, or age-related issues. This system provides a reliable solution by automating the process of medicine dispensing and reminding users at the correct time.

The system is developed using the ESP8266 microcontroller, which acts as the main controlling unit. It manages all operations such as time monitoring, user input processing, and controlling output devices. The system uses a 16×2 LCD display to provide real-time information to the user, including current time, medicine schedule, and alert messages such as "Take Medicine".

A servo motor is used as the key component for dispensing medicines. Medicines are stored in compartments, and when the preset time is reached, the servo motor rotates to release the required dose. This ensures accurate and controlled dispensing without human intervention. A manual push button is included to allow user interaction. It helps in setting time, modifying schedules, and acknowledging alerts. The system continuously checks time and activates the dispensing mechanism when required.



Overall, the Smart Pill Dispenser Robot is an efficient and cost-effective solution that improves medication adherence and reduces human errors. It can also be upgraded with IoT features for remote monitoring.

### **1.2 Problem in Manual Medication System**

In traditional medication systems, patients rely on memory or manual reminders to take their medicines. This method is not always reliable, especially for elderly people and patients who need to take multiple medicines at different times of the day. Forgetting to take medicines or taking them at the wrong time can cause serious health issues.

One of the major problems is that people often miss their doses due to busy schedules or lack of proper reminders. In some cases, patients may take incorrect doses due to confusion, especially when multiple medicines are involved. This can reduce the effectiveness of treatment and may even lead to dangerous situations.

### **1.3 Objectives of the Project**

The main objective of the Smart Pill Dispenser Robot is to develop an automated system that helps patients take medicines on time without missing any doses. The project focuses on improving healthcare management by reducing human errors and providing a reliable solution for medication scheduling.

One of the primary objectives is to design a system that can automatically dispense medicines at predefined time intervals. This ensures that the patient receives the correct dose at the correct time without manual effort.

Another objective is to provide a user-friendly interface using a 16×2 LCD display. The display helps the user to understand system status, view time, and receive alerts easily. The system is designed in such a way that even non-technical users can operate it.

The project also aims to include manual control using a push button. This allows the user to set time, adjust schedules, and interact with the system conveniently.

## **II. LITERATURE SURVEY**

### **2.1 Traditional Pill Dispenser Systems**

Traditional pill dispenser systems are simple devices used to organize and store medicines for daily use. These systems are commonly used by patients who need to take multiple medicines at different times of the day. The most common type of traditional pill dispenser is a pill box with compartments labeled according to days of the week or time intervals such as morning, afternoon, and night.

These systems help in organizing medicines and reducing confusion, especially for elderly patients. However, they are completely manual in operation and depend entirely on the user's memory. There is no automatic alert or reminder mechanism in these systems, which increases the chances of missing doses. Another limitation of traditional pill dispensers is the lack of accuracy and monitoring. The system does not ensure whether the patient has taken the medicine or not. There is also no control over the dosage, which may lead to underdose or overdose situations. This can negatively affect the health of the patient.

### **2.2 Automation using Microcontroller**

Automation using microcontrollers has significantly improved the efficiency and reliability of various systems, including healthcare devices. A microcontroller is a compact integrated circuit that can perform multiple tasks such as processing inputs, controlling outputs, and executing programmed instructions. In the context of medication management, microcontrollers are used to automate the process of reminding and dispensing medicines.

### **2.3 ESP8266 Based Healthcare Systems**

ESP8266-based systems have become very popular in the field of healthcare due to their simplicity, low cost, and ease of use. Arduino is an open-source microcontroller platform that allows developers and students to create various



electronic projects with minimal complexity. It is widely used in medical monitoring systems, patient alert systems, and automated devices.

In healthcare applications, Arduino is used to develop systems such as heart rate monitors, temperature sensors, automated medicine reminders, and smart pill dispensers. These systems help in improving patient care by providing real-time monitoring and automation.

One of the key advantages of Arduino-based systems is their user-friendly programming environment. The Arduino IDE allows easy coding using Embedded C language. It also supports a wide range of libraries, which simplifies the integration of components like LCD displays, sensors, and motors.

### System Development:-

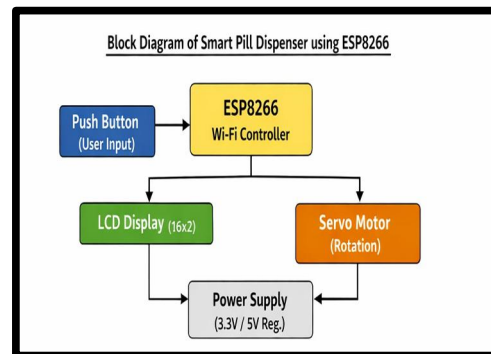

**Figure 3.1 Block Diagram of Smart Pill Dispenser using ESP8266**

The block diagram of the Smart Pill Dispenser using ESP8266 includes all the major components required for the system operation. At the center is the ESP8266 microcontroller, which connects to all input and output devices.

The push button is connected as an input device to provide user commands. The ESP8266 reads this input and processes it according to the program. The LCD display is connected to show real-time information such as current time, medicine alerts, and system status.

The servo motor is connected to the ESP8266 through a PWM pin. When the preset time is reached, the controller sends a signal to the servo motor, causing it to rotate and dispense the medicine.

All components are powered using a regulated power supply. The ESP8266 operates at 3.3V, so proper voltage regulation is necessary. The entire system works in coordination to ensure timely and accurate medicine dispensing. The system architecture of the Smart Pill Dispenser Robot defines the overall structure and interaction between different components of the system. It represents how the input, processing, and output units are interconnected to perform the desired operation efficiently.

The system is mainly divided into three parts: input unit, processing unit, and output unit. The input unit consists of a manual push button, which allows the user to interact with the system. Through this button, the user can set the medication time, modify settings, and acknowledge alerts.

The processing unit is the ESP8266 microcontroller, which acts as the brain of the system. It receives input signals from the push button, processes the data based on the programmed instructions, and controls the output devices accordingly. The ESP8266 continuously monitors the time and compares it with the preset schedule.

The output unit consists of a 16×2 LCD display and a servo motor. The LCD display shows important information such as current time, alerts, and system status. The servo motor is responsible for dispensing the medicine by rotating at a specific angle when the preset time is reached. The system also includes a power supply unit, which provides the required voltage to all components. Proper voltage regulation is maintained to ensure safe and efficient operation of the system.



All components are interconnected using appropriate wiring, and communication between them is handled through GPIO pins of the ESP8266. The architecture is designed to be simple, efficient, and scalable for future upgrades such as IoT integration.

### **ESP8266**

#### **Main Controller**

ESP8266 is the main controller of the system. It controls all operations and manages input and output devices. It acts as the brain of the system.

#### **Wi-Fi Capability**

It has built-in Wi-Fi functionality. This allows future IoT integration and remote monitoring. No external Wi-Fi module is required.

#### **Low Power Consumption**

ESP8266 consumes less power during operation. It is suitable for battery-based systems. This improves overall efficiency.

#### **GPIO Pins**

It has multiple GPIO pins for interfacing. Devices like LCD, servo motor, and button can be easily connected. It provides flexible control.

### **3.1.1 Features of ESP8266**

#### **High Speed Processor**

It has a fast processing unit. It can handle real-time operations efficiently. This ensures smooth system performance.

#### **Built-in Wi-Fi**

It supports direct internet connectivity. This makes it useful for smart and connected applications. No extra hardware is needed.

#### **Compact Size**

The module is small in size. It helps in designing compact circuits. Suitable for portable devices.

#### **Easy Programming**

It can be programmed using Arduino IDE. It supports Embedded C language. Easy for beginners and developers.

### **3.1.2 RTC Module (Real Time Clock)**

#### **Time Tracking Device**

RTC module keeps track of current time. It provides accurate timing for scheduling. It is essential for automation.

#### **Continuous Operation**

It continues to work even when power is off. This is possible due to battery backup. Time data is not lost.

#### **High Accuracy**

It provides precise time measurement. It reduces delay and timing errors. Reliable for long-term use.

#### **Interface with Controller**

It can be easily connected to ESP8266. Communication is simple and stable. Time reading becomes easy.

### **3.1.3 Features of RTC Module**

#### **Battery Backup**

It has an internal battery. It maintains time even during power failure. Ensures continuous operation.

#### **I2C Communication**

It uses I2C protocol for communication. Requires fewer wires. Makes circuit simple and efficient.

#### **Low Power Consumption**

It consumes very low power. Suitable for long-term applications. Improves efficiency.



**Accurate Timing**

It provides stable and accurate time. Very less deviation over long duration. Highly reliable.

**3.1.4 Servo Motor**

**Precise Rotation Control**

Servo motor rotates at a specific angle. It provides control from 0° to 180°. Useful for accurate movement.

**Medicine Dispensing**

It is used to release medicine. Rotates the container to drop pills. Ensures correct dosage.

**PWM Controlled Device**

It works using PWM signals. Easy to control using ESP8266. Provides smooth operation.

**3.1.5 Buzzer**

**Alert System**

Buzzer is used to give sound alerts. It notifies the user when it is time to take medicine. Acts as a reminder.

**Simple Device**

It is easy to use and connect. Requires minimal components. Low cost device.

**Low Power Usage**

Consumes very less power. Does not affect system performance. Efficient operation.

**3.2 LCD Display (16×2)**

**Display Information**

It displays time, alerts, and messages. Helps user understand system status. Provides clear output.

**User Interface**

Acts as interface between system and user. Shows instructions and alerts. Easy to read.

**Low Cost and Simple**

It is affordable and widely used. Simple to operate. Suitable for basic display needs.

**Easy Interfacing**

Can be easily connected with ESP8266. Libraries are available. Programming is simple.

**IV. APPLICATIONS, ADVANTAGES**

**Applications of Smart Pill Dispenser**

**Healthcare for Elderly People**

It helps elderly patients remember to take medicines on time. The system reduces dependency on others. It improves regular medication habits.

**Hospital Use**

Used in hospitals to manage patient medication schedules. It reduces the workload of nurses. Ensures accurate and timely medicine delivery.

**Chronic Disease Patients**

Useful for patients with diseases like diabetes and BP. These patients require regular medication. The system ensures proper timing.

**Home Automation System**

Acts as a personal medicine assistant at home. Helps busy people who forget medicines. Provides alerts and automatic dispensing.

**Remote Monitoring (Future Scope)**

Can be connected to IoT for remote monitoring. Doctors or family members can track medicine usage. Improves patient care.



### Advantages of Smart Pill Dispenser

#### Timely Medication

The system ensures medicines are taken on time. It improves treatment effectiveness. Reduces chances of missed doses.

#### Reduces Human Error

Automation reduces mistakes in medication. Prevents wrong timing and dosage. Improves patient safety.

#### User-Friendly Design

Easy to use with LCD and push button. Suitable for all age groups. Does not require technical knowledge.

## V. CIRCUIT DESIGN

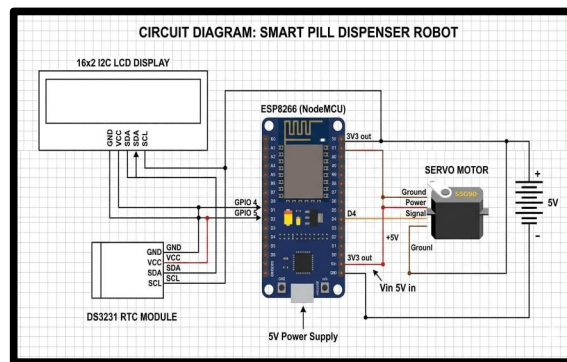

### Circuit Diagram of Smart Pill Dispenser System

The circuit diagram of the Smart Pill Dispenser System represents the complete electrical connections between all the components used in the project. The ESP8266 microcontroller acts as the central unit, and all input and output devices are connected to it through appropriate GPIO pins. The main components included in the circuit are the ESP8266, RTC module, LCD display, servo motor, push button, and buzzer.

The push button is connected to one of the GPIO pins of the ESP8266 and is used as an input device. It allows the user to set the time and control system operations. A pull-down resistor is used to ensure stable input signals. The RTC module is connected using I2C communication lines (SDA and SCL), which provide real-time clock data to the controller.

The LCD display is connected to display important information such as current time, system status, and alerts. It can be connected in either 4-bit or I2C mode for efficient communication. The servo motor is connected to a PWM-enabled pin of the ESP8266, which allows precise control of its rotation angle for dispensing medicine.

## VI. FUTURE SCOPE

### Integration with Wireless Communication

In the future, the Smart Pill Dispenser Robot can be significantly enhanced by integrating advanced wireless communication technologies such as Wi-Fi, Bluetooth, or Zigbee. This integration will allow the system to communicate with external devices without the need for physical connections, thereby increasing flexibility and ease of use. Since the ESP8266 already has built-in Wi-Fi capability, it provides a strong foundation for implementing wireless communication features in the system.

With wireless connectivity, the system can send real-time notifications and alerts to users, caregivers, or family members. For instance, if a patient forgets to take their medicine, the system can automatically send a reminder message or notification to a registered mobile device. This feature is especially beneficial for elderly patients who require constant supervision and support.



Wireless communication also enables remote access and control of the system. Users can modify medication schedules, update system settings, or monitor system activity from a distance. This eliminates the need for physical interaction with the device and improves overall convenience.

Furthermore, wireless communication allows integration with other smart devices, creating a connected healthcare ecosystem. It enhances system reliability and ensures better monitoring and management of patient medication. Therefore, incorporating wireless communication will transform the Smart Pill Dispenser into a more advanced, efficient, and user-friendly system.

## VII. CONCLUSION

### Project Summary

The Smart Pill Dispenser Robot is a reliable and efficient system developed to automate the process of medicine dispensing. The main aim of the project was to design a system that ensures timely medication without depending on human memory. The system was successfully implemented using ESP8266 as the main controller along with components such as RTC module, LCD display, servo motor, push button, and buzzer.

The working of the system is based on real-time monitoring and automated control. The RTC module provides accurate time, which is continuously monitored by the ESP8266. When the preset time matches the current time, the system activates the servo motor to dispense medicine and alerts the user through the LCD display and buzzer.

The project also includes user interaction through a push button, allowing the user to set and control the medication schedule. The hardware and software integration was carried out successfully, ensuring smooth operation of the system. Overall, the Smart Pill Dispenser Robot provides a practical and effective solution for medication management. It reduces human effort, minimizes errors, and improves healthcare efficiency.

### Achievement of Objectives

The objectives of the Smart Pill Dispenser Robot project were clearly defined at the beginning, and all of them have been successfully achieved. The primary objective was to develop an automated system that can dispense medicines at the correct time without manual intervention.

The system was able to monitor time accurately using the RTC module and perform actions based on predefined schedules. The servo motor mechanism was successfully implemented to dispense medicine precisely at the required time.

## REFERENCES

- [1]. <https://www.arduino.cc>
- [2]. <https://www.espressif.com>
- [3]. <https://www.electronicsforu.com>
- [4]. <https://www.circuitdigest.com>
- [5]. <https://www.instructables.com>
- [6]. Arduino IDE Documentation and Tutorials
- [7]. ESP8266 Datasheet and Technical Reference
- [8]. RTC Module (DS3231) Datasheet
- [9]. Servo Motor Technical Guide
- [10]. Research Papers
- [11]. "Smart Medicine Dispenser Using IoT",
- [12]. International Journal of Engineering Research, 2020
- [13]. "Automated Pill Dispenser System",
- [14]. IEEE Conference Paper, 2019
- [15]. "IoT Based Healthcare Monitoring System",



- [16]. International Journal of Advanced Research, 2021
- [17]. “Design of Smart Medication System Using Microcontroller”,
- [18]. Elsevier Publication, 2018
- [19]. “Automated Drug Delivery System”,
- [20]. Springer Research Paper, 2022

