

Automated Prototype of Substation

Yash Kalyankar¹, Sarthak Paraskar², Vedant Hiwale³, Sharvari Deshmukh⁴

Electrical Department¹⁻⁴

Shri Sant Gajanan Maharaj College of Engineering, Shegaon, India

Abstract: *In the modern electrical power system, substations are one of the integral parts in the transmission and distribution of electrical power. However, it is very difficult to understand the working of substations and their protection systems due to inaccessibility, safety, and a lack of real-time experience. Even in simulating substations in a lab, a traditional substation model is used, which is mostly static in nature*

Keywords: Substation Automation, Power System Protection, Fault Simulation, ESP32, Embedded Systems, Circuit Breaker Control, Protection Coordination, Voltage and Current Sensors, Smart Grid, Real-Time Monitoring, Electrical Substation Model

I. INTRODUCTION

In modern electrical engineering, the power system plays a vital role in the generation, transmission, and distribution of electrical energy. Among the various components of the power system, the substation plays a vital role in the transformation of voltage levels in the safe and efficient transmission of electrical energy from the power generation sites to the consumers. The substation consists of various essential components like transformers, circuit breakers, isolators, current transformers, potential transformers, etc.

The main aim of a substation is not only to increase or decrease the voltage levels but also to control, protect, and monitor the flow of electrical power. Substations are used to supply electrical power to different types of loads like residential, commercial, and industrial sectors. Faults in the substation can lead to power failures, equipment damage, and even life risk. Hence, the working of the substation and its protection are very important for electrical engineering students and professionals. Nevertheless, it is difficult to acquire practical experience in substations. This is because real substations operate at high voltage levels and are associated with safety hazards. Thus, it is difficult to frequently visit substations. Moreover, when conducting industrial site visits, it is difficult to witness internal activities such as fault occurrences. This means that students do not comprehend the real-time behavior of substations.

Therefore, various educational institutions have been using models of substations. Nevertheless, such models are mainly static in nature. This implies that they only illustrate the physical layout of substations. Thus, they do not illustrate real-time activities. This is because they do not have the capacity to emulate fault occurrences and protection schemes. These activities are crucial in understanding real-time power systems.

Currently, various technologies such as embedded systems, sensors, and automation are rapidly improving. This means that it is possible to create intelligent models that can emulate real-time power systems. This is because various microcontrollers such as ESP32 have sufficient processing abilities. These microcontrollers can effectively handle real-time activities. This implies that it is possible to create automated substations that can monitor activities, detect faults, and activate protection schemes. In the above context, the proposed project aims at the design and development of a prototype of a substation that could be automated to the extent that it could simulate fault conditions in real time and also display the concept of coordination in the protection schemes used in the substations. This project would involve the integration of the ESP32 microcontroller with the voltage and current sensors, simulating the faults, and also controlling the circuit breakers and the isolators in the substations.

The primary purpose of the project:

The primary purpose of the project is to bridge the gap that exists between the theoretical knowledge and the practical understanding of the substations and the working of the substations in the presence of faults or otherwise.



II. SYSTEM ARCHITECTURE

The system architecture is centered around the ESP32, which acts as the main control unit for monitoring and automation. Voltage sensors (ZMPT101B) and current sensors (ACS712) are used to continuously measure electrical parameters from different phases and feed real-time data to the ESP32. Based on these inputs, the controller detects fault conditions and executes protection actions. A relay driver circuit using ULN2803 controls the circuit breakers for fault isolation, while a PCA9685 servo driver module operates multiple servo motors to simulate isolator switching mechanisms. The system is powered through regulated supplies using LM2596 and AMS1117 voltage regulators to provide stable 5V and 3.3V outputs. Overall, the architecture integrates sensing, processing, and actuation modules to create an automated and interactive substation prototype capable of real-time fault simulation and protection coordination.

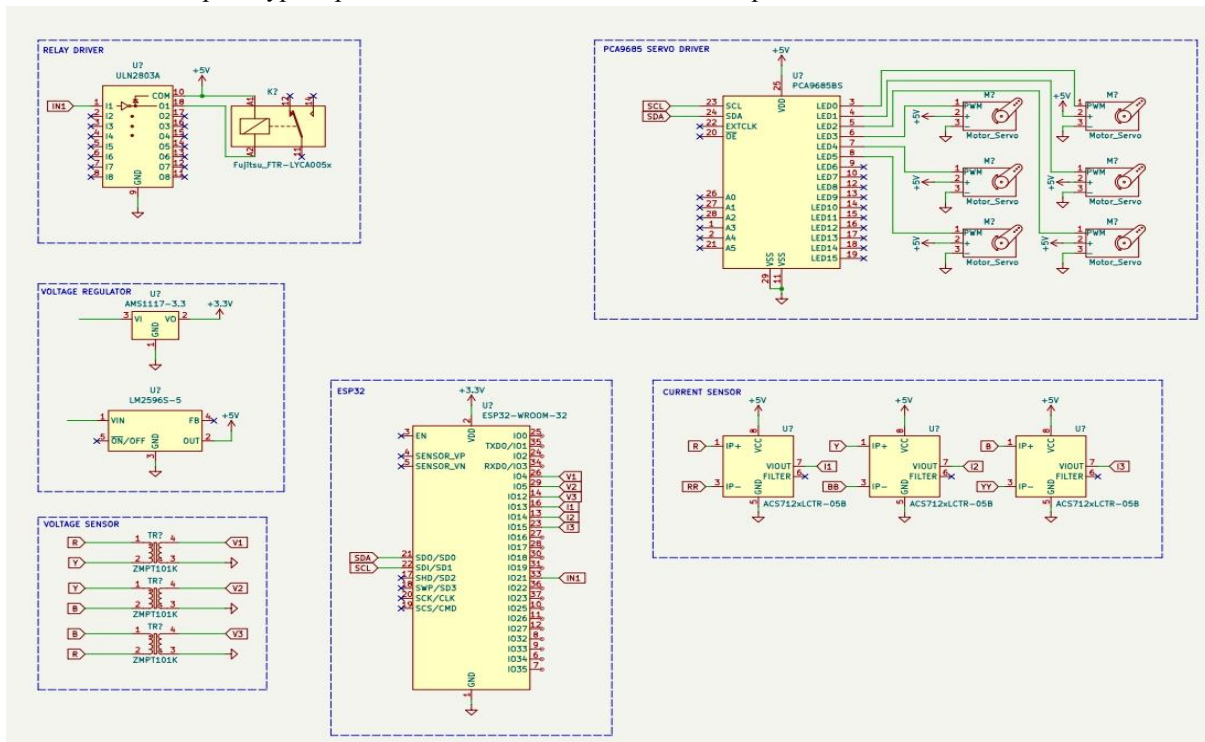

Fig. 1 System Architecture of ESP32-Based Automated Substation Prototype

The Arduino Mega 2560 is the central controller of the system. It processes the information and sends it to the ESP32 module for wireless communication. It then sends the information to the Firebase platform for storage in the cloud. A web-based dashboard is then used to retrieve the information and display it in real-time. This way, the system can be easily monitored in real-time. It is possible to monitor the battery voltage, current, and temperature. In addition, the battery's SOC and health can be monitored in real-time.

III. METHODOLOGY

A. System Overview

The proposed system is an automated version of a substation designed to provide real-time simulation of the operations, fault detection, and protection coordination in a safe environment. The system uses a reduced three-phase power supply to provide real-time simulation of the actual operations of the substation.



The proposed system consists of the following:

- Power supply/transformer unit
- Busbar feeder arrangement
- Voltage sensing unit
- Current sensing unit
- Protection system/relay, circuit breaker, isolators
- ESP32 control unit

The proposed system uses the ESP32 microcontroller as the control unit, which continuously monitors the electrical parameters and provides protection by executing the program based on the predefined conditions.

B. Power Distribution/Transformer

The proposed system uses a reduced three-phase 110 V AC supply to the input of the system, which represents the incomer in the actual substation. The three-phase 110 V AC supply is distributed through the busbar feeder arrangement in the proposed system. The reduced 110 V three-phase AC supply is applied to the input of the system, simulating the incomer in the substation.

There are three single-phase transformers in the system, and they are connected to the feeder. Each of the primary winds of the transformer receives a 110 V AC supply, while the secondary wind of the transformer is in a star connection to obtain a reduced voltage of 24 V AC.

The reduced voltage ensures the safe working of the system while maintaining the actual behavior of the system.

The transformer unit plays a vital role in the demonstration of the actual working of the system.

C. Sensing and Monitoring Mechanism

The system uses the following to perform the monitoring function in real time:

- Voltage sensor (ZMPT) for voltage measurement
- Current sensor (ACS) for current measurement

These sensors constantly collect the electrical values from the feeder side and send the analog signal to the ESP32 microcontroller for processing and comparing the values with the threshold limits.

During normal conditions, the current value will be in the safe range of 0.3-0.4 A. But in case of a fault, the current value will increase significantly to ~1 A.

D. Fault Creation Mechanism

To create a fault condition in the system in a controlled environment and mimic the conditions of the real world, a controlled line-to-ground fault is created in the system using a relay-based switching mechanism.

A 25 Ω , 50 W ceramic resistor is employed in the system to limit the fault current and ensure the safe operation of the prototype. When the relay is activated in the system, the fault is created in the system and the current flows through the resistor.

The fault current is calculated using the following equation:

$$I(\text{fault}) = \frac{V}{R} = \frac{24}{25} \cong 0.96A$$

This mechanism is employed in the system for the safe simulation of the fault condition without damaging the system components.

E. Fault Detection and Decision Logic

In the proposed system, the ESP32 microcontroller is employed for continuously monitoring the sensor data and detecting any abnormal conditions in the system. A predefined threshold current of approximately 0.6 A is set in the system.

If current < threshold



Normal operation

If current \geq threshold

Fault detected

Once the fault is detected, the controller initiates the protection sequence. The logic ensures quick and accurate detection while minimizing false triggering.

F. Protection and Control Mechanism

The protection mechanism is implemented in such a way that it mimics the real-world protection coordination in the substation. It consists of:

- Circuit Breaker (Controlled through Relay)
- Isolators (Controlled through Servo Mechanism)

The following operations are performed in the event of a fault:

- Circuit Breaker: Immediately Trips (~50 ms)
- Isolators: After a delay of ~300 ms

This ensures the de-energizing of the circuit before isolation.

The system remains in the isolated state until a reset is manually initiated.

G. Automation and Control using ESP32

ESP32 is a microcontroller that is the brain of the system and performs the following operations:

- Continuous monitoring of voltage and current
- Processing of sensor data
- Fault detection using threshold value
- Control of relay and servo mechanism
- Execution of protection sequence

Using the ESP32 microcontroller provides the following advantages:

- Real-time operation
- Fast response
- Flexibility for future enhancements using IoT

H. Working Procedure

The overall operation of the system is summarized as follows:

- The system is powered ON with a reduced three-phase supply
- ESP32 initializes sensors and control modules
- Voltage and current are continuously monitored
- System operates normally under safe conditions
- Fault is introduced using relay mechanism
- Sensors detect abnormal current values
- ESP32 identifies fault based on threshold
- Circuit breaker trips immediately
- Isolators open after a predefined delay
- Faulty section is isolated
- System remains off until manual reset



IV. IMPLEMENTATION

4.1 Circuit Design

The system includes connections between ESP32, sensors, relay modules, and protection devices. Proper circuit design ensures accurate signal processing and reliable operation.

4.2 Prototype Development

The prototype is developed by integrating all components into a compact model. The design ensures safety, usability, and proper demonstration of substation operations.

4.3 HARDWARE COMPONENTS

A. ESP32 Microcontroller

ESP32 acts as the central control unit of the system. It processes sensor data, detects faults, and controls protection devices. It offers high processing capability and supports wireless communication for future enhancements.



Fig. 2 ESP32 Microcontroller

B. Voltage and Current Sensors

Voltage (ZMPT) and current (ACS) sensors are used to measure electrical parameters and provide real-time feedback to the controller.



Fig. 3 ACS



Fig. 4 ZMPT

C. Circuit Breaker

The circuit breaker is used to interrupt the current during fault conditions and protect the system from damage. Here we are using SSTs to simulate the circuit breakers



Fig. 5 Circuit Breaker



D. Isolator

The isolator is used to disconnect the faulty section for maintenance and safety. It operates only after the circuit breaker opens.



Fig. 6 Micro Servo Motor

And here we are using servo motors to replicate the isolators

E. Transformer

The transformer is used to step down voltage to a safe level for operation and testing.

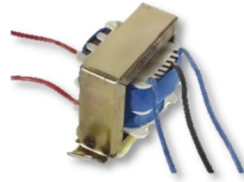

Fig. 7 Transformer

G. Power Supply

A stable power supply is used to ensure proper functioning of all components.

V. RESULTS AND DISCUSSION

The system was tested in different conditions. When the fault was inserted, the sensors were able to detect abnormal current values, and the ESP32 started the protection sequence.

The circuit breaker tripped immediately, followed by the isolators after a short delay. The system was able to isolate the faulty section.

When the system was tested in normal conditions, it was seen that the system was not triggering falsely, showing that the system was working correctly.

The response time of the system was fast, and the protection mechanism was working correctly.

VI. CONCLUSION

The automated substation prototype developed in this project has provided an effective solution for demonstrating substation operations, fault detection, and protection schemes.

The system has successfully integrated various substation operations, fault detection, and protection schemes in one platform, making it very useful for learning and training. The system has greatly improved learning by providing an understanding of substation operations.

VII. ACKNOWLEDGMENT

We acknowledge the support of the Electrical Department, Shri Sant Gajanan Maharaj College of Engineering, Shegaon, for providing the necessary facilities to carry out this research. We also express our gratitude to our project guide for their valuable guidance and technical support. The contributions of all team members in the development and implementation



of this work are duly recognized. We further thank all individuals who provided indirect support during the course of this study.

REFERENCES

- [1]. Md. Abu Talha et al., "IoT-Based Real-Time Monitoring and Control System for Distribution Substation," IEEE International Conference on Power Systems (ICPS), 2023.
- [2]. Z. Ullah et al., "IoT-based monitoring and control of power substations and smart grids," Energy (ScienceDirect), 2023.
- [3]. M. S. Hossain et al., "A Smart IoT-Based System for Monitoring and Controlling Substation Equipment," Sustainable Energy Technologies and Assessments, 2019.
- [4]. Md. Ashiquzzaman et al., "IoT-Based Power Monitoring and Management System of a Distribution Substation," IEEE Conference on Power Systems, 2023.
- [5]. C. Deore et al., "IoT-Powered Substation Surveillance System," International Journal of Current Science Research and Review, 2024.
- [6]. A. A. Noman et al., "Design and Implementation of IoT-Driven Monitoring System for Smart Power Grids," MDPI Engineering Proceedings, 2025.
- [7]. M. Kalimoldayev et al., "Development of an IoT-Based Monitoring System for Electric Power Substations," Polish Academy of Sciences Journal, 2023.
- [8]. "IoT-Based Substation Monitoring and Control System," IJRASET Journal, 2021.
- [9]. "IoT-Based Smart Framework for Monitoring Power Devices in Substations," Computers, Materials & Continua, 2023.

