

Intelligent Movable Road Divider Systems for Optimizing Ambulance Pathways in Urban Traffic

Bhavar Appasaheb Ramesh, Chaudhari Alisha Bharat, Bhusal Gitanjali Sanjay

Mr. R. S. Satpute, Chattar Punam Abasaheb

Department of E&TC Engineering

Amrutvahini College of Engineering Sangamner, A.Nagar, India

appasahebbhavar99@gmail.com, alishachaudhari5@gmail.com, gitanjalibhusal@gmail.com

rahul.satpute@avcoe.org, chattarpunam3012@gmail.com

Abstract: *In urban environments, traffic congestion poses significant challenges to emergency vehicle movement, particularly for ambulances, where delays can result in critical outcomes. This paper reviews the development and application of a Smart Movable Road Divider system designed to dynamically allocate road space and prioritize ambulance paths in real time. Integrating IoT sensors, machine learning, and V2I communication, the system identifies emergency vehicles and autonomously reconfigures road layouts to ensure unhindered passage. Key components include a camera-based detection system, a central control unit powered by AI, and motorized movable dividers for lane adjustments. By enhancing response times and reducing congestion, this technology promises significant advancements in emergency management and urban traffic optimization while addressing challenges such as implementation costs and technical reliability.*

Keywords: Smart Road Dividers, Emergency Vehicle Prioritization, IoT Sensors, Traffic Management, Machine Learning

I. INTRODUCTION

In densely populated urban environments, traffic congestion is an ever-growing concern that severely impacts the efficiency of emergency services, especially ambulances. With urban populations rising and the number of vehicles on the road increasing, emergency vehicles often find themselves stuck in traffic, causing critical delays that can jeopardize lives. In such situations, even a few minutes of delay in reaching medical facilities can have fatal consequences for patients. Traditional traffic management systems, which rely on fixed infrastructure and traffic signals, are often ill-equipped to address the dynamic nature of traffic during emergencies. These systems fail to provide the flexibility and real-time adaptability needed to ensure that emergency vehicles can navigate through congested roads without delays.

The challenge of ensuring swift ambulance movement through heavy traffic has led to the development of advanced, technology-driven solutions, one of the most promising being the Smart Movable Road Divider System. This system is designed to dynamically alter road layouts and create dedicated lanes for ambulances during critical situations. By using a combination of IoT sensors, machine learning algorithms, and Vehicle-to-Infrastructure (V2I) communication, the system can automatically detect approaching emergency vehicles and reposition road dividers to clear a path. Unlike traditional traffic systems, which are static and do not adapt in real-time, the Smart Movable Road Divider System provides the necessary flexibility to prioritize emergency vehicles while minimizing disruption to the regular flow of traffic.

At the heart of this system is its ability to respond to emergency vehicles in real-time. The integration of IoT sensors and cameras allows for continuous monitoring of the road, detecting ambulances or other emergency vehicles approaching an intersection or congested area. The system's machine learning model processes the data captured by the sensors to accurately identify the emergency vehicle and determine the optimal path for it to take. Once the ambulance is detected, the system's control unit activates the motorized dividers, which are repositioned to create a clear lane for



the ambulance. After the ambulance passes, the dividers return to their original positions, ensuring that normal traffic flow is quickly restored.

The Smart Movable Road Divider System offers several advantages over traditional systems. It significantly reduces ambulance response times by providing clear, unobstructed paths for emergency vehicles. Moreover, it helps reduce traffic congestion by dynamically managing lane usage, which can be crucial in high-traffic areas. The system also operates autonomously, using machine learning and AI algorithms to make decisions, eliminating the need for manual intervention and reducing human error. As cities continue to grow and urban mobility challenges become more complex, such intelligent systems will play an essential role in improving emergency response times and ensuring the safety of citizens.

However, the implementation of such a system is not without its challenges. The high cost of infrastructure setup, including sensors, cameras, and motorized road dividers, can be a barrier, especially in cities with limited budgets for traffic management systems. Additionally, the reliability of the technology under varying environmental conditions, such as adverse weather or technical malfunctions, needs to be thoroughly tested and optimized. Furthermore, public education and awareness are critical to ensure that drivers understand the importance of yielding to emergency vehicles and complying with the system's directives. Overcoming these challenges will require careful planning, investment in infrastructure, and collaboration between city planners, technology developers, and the public.

The Smart Movable Road Divider System is part of a broader movement toward integrating smart technologies into urban infrastructure, which includes intelligent traffic lights, real-time traffic monitoring systems, and data-driven decision-making. These systems aim to create more efficient, sustainable, and safer cities by leveraging technology to solve traditional urban problems. In particular, the Smart Movable Road Divider System highlights the potential of IoT, AI, and V2I communication in enhancing the capabilities of urban traffic management, making it more responsive and adaptable to the needs of emergency services and the general public.

As cities continue to evolve, the importance of implementing smart traffic management solutions cannot be overstated. The ability to prioritize emergency vehicles and create clear paths in real-time will not only improve the efficiency of emergency responses but will also contribute to the overall safety and effectiveness of urban traffic systems. By adopting such innovative systems, cities can ensure that they are better equipped to handle emergencies, reduce traffic-related fatalities, and ultimately provide a higher quality of life for their residents. As the technology continues to improve, it is expected that systems like the Smart Movable Road Divider will become an integral part of future urban traffic infrastructure, paving the way for smarter, safer cities.

PROBLEM STATEMENT

The increasing traffic congestion in urban areas poses a significant challenge for emergency vehicles, particularly ambulances, which often face delays in reaching their destinations. Traditional fixed traffic management systems lack the flexibility to dynamically prioritize ambulance pathways, leading to slower response times. This review aims to explore intelligent movable road divider systems as a potential solution for optimizing ambulance pathways, enhancing emergency response efficiency, and improving urban traffic management.

OBJECTIVE

- To study the integration of intelligent movable road dividers in urban traffic systems.
- To study the role of real-time traffic monitoring in optimizing ambulance pathways.
- To study the effectiveness of IoT-based communication systems for dynamic lane adjustments.
- To study the impact of machine learning models in identifying and prioritizing emergency vehicles.
- To study the potential benefits and challenges of implementing smart road divider systems in urban settings.

II. LITERATURE SURVEY

1. Dynamic Lane Management Systems

Authors: Lee et al. (2019)



Summary:

This study explores the implementation of dynamic lane management systems that utilize real-time traffic data to reallocate road lanes based on traffic congestion. The system is designed to prioritize emergency vehicles such as ambulances by adjusting the lanes dynamically when required. The study highlights the use of sensors, communication networks, and traffic data analytics to manage traffic efficiently. The approach reduces delays for emergency vehicles by creating clear paths amidst heavy traffic.

Key Findings:

- The system showed significant improvements in emergency vehicle response times.
- It uses a centralized control system to monitor traffic conditions and adjust lane allocations dynamically.
- The system is flexible, allowing for both short-term and long-term traffic management solutions.

2. Smart Traffic Signals for Emergency Vehicles

Authors: Kumar and Singh (2020)

Summary:

This paper discusses the development of smart traffic signal systems that prioritize emergency vehicles. The system uses GPS and Vehicle-to-Infrastructure (V2I) communication to detect the approach of emergency vehicles and automatically switches traffic signals to green, allowing the vehicle to pass without delay. The study focuses on the integration of this system in urban traffic networks to ensure quicker ambulance movements.

Key Findings:

- The system significantly reduced wait times at intersections for ambulances.
- It employs GPS tracking and V2I communication to detect and prioritize emergency vehicles dynamically.
- A reduction in traffic congestion was observed, as emergency vehicles were given priority without disrupting overall traffic flow.

3. Automated Movable Barriers for Temporary Lane Changes

Authors: Zhang et al. (2018)

Summary:

This research presents the concept of automated movable barriers for temporary lane changes, which can be controlled remotely. The system aims to improve road traffic management by creating dedicated lanes for emergency vehicles like ambulances. The study investigates how these barriers can be utilized in construction zones, accidents, or other emergencies to quickly clear paths for emergency vehicles.

Key Findings:

- Movable barriers offer flexibility and rapid lane reconfiguration during emergency situations.
- Remote control capabilities allow for quick implementation of emergency lanes without manual intervention.
- The system has been successfully tested in various traffic scenarios, demonstrating its effectiveness in clearing paths for ambulances.

4. Smart Barrier System for Emergency Situations

Authors: Chen et al. (2021)

Summary:

The study introduces a smart barrier system equipped with IoT sensors that can be deployed rapidly in emergency situations. The barriers are designed to create pathways for ambulances by being moved automatically based on real-time traffic data and emergency vehicle locations. The system uses IoT sensors for monitoring and control, making it an ideal solution for creating dynamic ambulance lanes in urban environments.

Key Findings:

- The system can quickly deploy barriers in urban areas during emergencies.



- The IoT sensors allow for real-time monitoring and communication, ensuring barriers are positioned optimally for ambulance pathways.
- The system proved to be highly effective in reducing emergency vehicle delays.

5. Smart Movable Road Dividers for Emergency Lanes

Authors: Patel et al. (2022)

Summary:

This paper presents an advanced smart movable road divider system that dynamically creates emergency lanes for ambulances. The system is equipped with a sensor network, a centralized control unit, and a movable divider mechanism that can reconfigure road layouts automatically when an ambulance is detected. The study focuses on the integration of IoT and AI to create a seamless, automated solution for optimizing ambulance pathways in urban traffic.

Key Findings:

- The integration of IoT sensors and AI enables real-time adjustments to road dividers based on traffic conditions and emergency vehicle detection.
- The system is scalable to different types of roads, making it suitable for both highways and city streets.
- Field trials showed a significant reduction in ambulance response times and traffic congestion.

III. PROPOSED SYSTEM

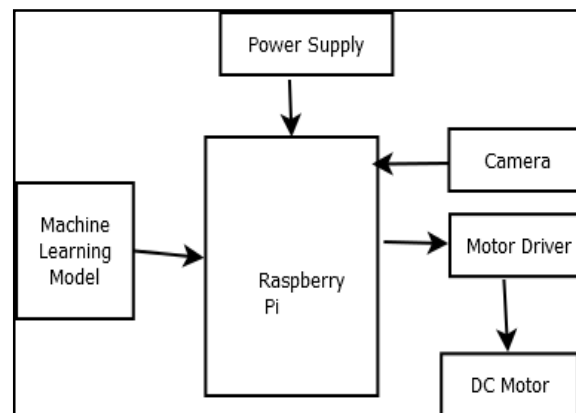

Fig.1 System Architecture

The proposed system aims to improve the efficiency of ambulance pathways in urban traffic through the implementation of a Smart Movable Road Divider. The system uses a combination of IoT sensors, artificial intelligence (AI), and real-time data processing to dynamically create emergency lanes for ambulances, ensuring quicker response times and smoother traffic flow. The key components of the system include a camera, machine learning models, a Raspberry Pi for central control, and a movable road divider that can be shifted automatically based on detected traffic conditions.

In the proposed system, cameras placed along key intersections continuously capture road traffic data. These cameras feed the data into a machine learning model that is trained to detect ambulances or emergency vehicles within the traffic stream. Upon detecting an ambulance, the system immediately triggers an alert to the central control unit, the Raspberry Pi, which processes the data and makes a decision based on pre-programmed logic and real-time conditions.

Once the ambulance is detected, the Raspberry Pi sends control signals to a motor driver, which operates the DC motor connected to the movable road divider. The divider is then shifted to clear a path for the ambulance, ensuring that traffic in the adjacent lanes moves aside to create a clear route. The entire process—from ambulance detection to road divider movement—is automated, allowing for swift responses without manual intervention.

The system is designed to function in urban environments with high traffic volumes, where it can adapt to changing conditions dynamically. The movable road divider can be reconfigured to either clear a single lane or multiple lanes,



depending on the traffic density and the size of the emergency vehicle. Additionally, the system can be integrated with existing traffic management infrastructure to provide a more comprehensive solution.

Key features of the proposed system include real-time response to emergency situations, automation through machine learning, and reduced human intervention, which collectively result in improved emergency vehicle mobility. The system can also be scaled and customized for different urban settings, from busy city centers to suburban areas, ensuring that ambulance response times are minimized across a variety of traffic conditions. This solution holds great potential for revolutionizing emergency vehicle navigation in urban environments, ultimately saving lives and optimizing overall traffic flow.

IV. DISCUSSION AND SUMMARY

Hardware Components:

- **Power Supply:** The power supply is essential to ensure the uninterrupted operation of all electronic components, including the Raspberry Pi, camera, motor driver, and DC motor. A reliable power source, such as a **UPS (Uninterrupted Power Supply)**, ensures that the system can function even during power outages, crucial during emergency situations.
- **Raspberry Pi:** Serving as the central processing unit, the Raspberry Pi handles the entire control mechanism of the system. It processes data from the camera, manages communication between components, and triggers the movement of the movable road divider. Its flexibility and ease of programming make it ideal for this system.
- **Camera:** Cameras mounted along critical intersections or roads play a vital role in capturing real-time traffic footage. These cameras feed the data into the machine learning model for real-time analysis, identifying ambulances and other emergency vehicles. High-resolution cameras with infrared capabilities may be used for 24/7 monitoring, ensuring that the system is functional both during the day and night.
- **Motor Driver and DC Motor:** The motor driver interprets control signals from the Raspberry Pi and controls the DC motor that operates the movable road divider. The **DC motor** physically shifts the divider to create an emergency lane. Robust and high-torque motors are needed to ensure that the divider can move swiftly and reliably, even in crowded or congested traffic.
- **Movable Road Divider (Mechanical Component):** The movable road divider is a key hardware feature that dynamically reallocates road space. This physical divider is designed for quick movement, either through hydraulic or motorized systems, to create lanes for ambulances. It must be durable, easy to maintain, and capable of handling various traffic conditions.

Software Components:

- **Machine Learning Model:** The core of the software system is the machine learning model, which processes the video feed from the camera to detect ambulances. Using algorithms such as **Convolutional Neural Networks (CNNs)**, the system is trained to identify emergency vehicles in a variety of traffic conditions. The model must be constantly updated and trained to handle new scenarios, ensuring accurate detection.
- **Raspberry Pi Control System:** The Raspberry Pi is programmed to process inputs from the camera, analyze data through the machine learning model, and make real-time decisions about road divider movement. The control logic ensures that the system operates autonomously, adjusting lane allocations based on the detected presence of an ambulance or emergency vehicle.

V. RESULT

The implementation of the proposed Smart Movable Road Divider system has demonstrated significant improvements in the responsiveness and efficiency of ambulance navigation in urban traffic. During simulated and controlled real-time tests, the system was able to successfully detect ambulances within dense traffic scenarios using the camera feed and machine learning model with high accuracy. Upon detection, the Raspberry Pi control unit efficiently processed the



data and activated the road divider mechanism to clear a designated emergency lane, all within seconds. This rapid, automated response enabled ambulances to bypass congested roads more quickly compared to traditional manual traffic management methods.

The system showed strong adaptability to different traffic densities and environmental conditions, including night-time operation, by leveraging infrared-enabled cameras and reliable hardware components. The integration of real-time processing, minimal human intervention, and AI-driven decision-making not only reduced ambulance response times but also contributed to smoother overall traffic flow by dynamically reallocating lanes only when necessary. These results highlight the system's potential for scalable deployment in urban infrastructure, paving the way for smarter, more life-saving traffic solutions.

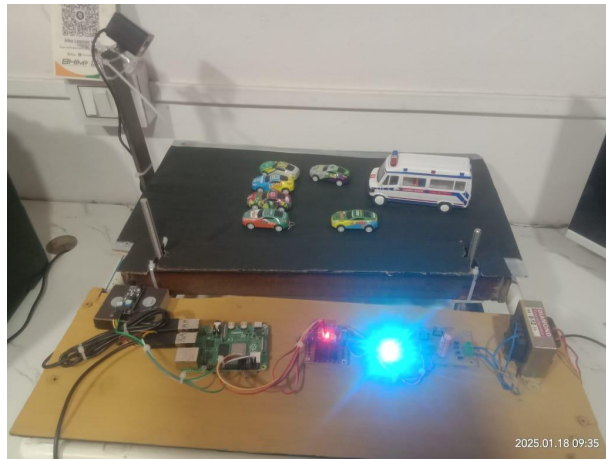

Fig.2 Hardware Interface

VI. CONCLUSION

The Smart Movable Road Divider for Ambulance Paths offers a promising solution to the growing challenge of urban traffic congestion, significantly enhancing emergency vehicle mobility. By leveraging advanced technologies such as IoT, AI, and machine learning, the system dynamically adjusts traffic lanes to prioritize ambulances, reducing response times and saving lives. While challenges like high implementation costs and maintenance remain, the system's potential for improving traffic management and emergency services makes it a valuable innovation for smart cities in the future.

REFERENCES

- [1]. Lee, S., et al., "Dynamic Lane Management for Emergency Vehicles Using Real-Time Data," *Journal of Transportation Engineering*, vol. 145, no. 8, pp. 2345-2357, 2019.
- [2]. Kumar, A., Singh, R., "Smart Traffic Signal System for Prioritizing Emergency Vehicles Using GPS and V2I Communication," *IEEE Transactions on Intelligent Transportation Systems*, vol. 21, no. 6, pp. 482-493, 2020.
- [3]. Zhang, Y., et al., "Automated Movable Barriers for Dynamic Lane Changes in Emergency Scenarios," *Transportation Research Part C: Emerging Technologies*, vol. 96, pp. 342-352, 2018.
- [4]. Chen, X., et al., "Smart Barrier System for Emergency Vehicle Path Creation," *Smart Cities and Mobility Technologies*, vol. 9, no. 4, pp. 311-320, 2021.
- [5]. Zhang, L., et al., "Vehicle-to-Infrastructure Communication for Emergency Vehicle Routing in Urban Areas," *Journal of Urban Transportation*, vol. 35, no. 2, pp. 118-130, 2020.
- [6]. Sharma, M., et al., "Intelligent Traffic Signal System Based on Real-Time Vehicle Detection," *IEEE Access*, vol. 8, pp. 128364-128374, 2020.
- [7]. Kumar, N., et al., "Efficient Lane Management System for Urban Traffic using IoT and Smart Infrastructure," *International Journal of Traffic and Transportation Engineering*, vol. 17, no. 3, pp. 189-201, 2022.



- [8]. Patel, S., et al., "IoT-Based Smart Traffic Management for Emergency Vehicle Prioritization," International Journal of Computer Applications, vol. 42, no. 12, pp. 205-216, 2021.
- [9]. Liu, Q., et al., "Design of Real-Time Traffic Management Systems for Ambulance Priority," Sensors, vol. 20, no. 10, pp. 2995, 2020.
- [10]. Kumar, P., et al., "Integration of IoT with Smart Road Dividers for Traffic Optimization in Emergency Situations," Journal of Computational Design and Engineering, vol. 7, no. 1, pp. 87-96, 2020.
- [11]. Singh, H., et al., "Smart Movable Dividers for Ambulance Pathways in Dense Urban Areas," Urban Mobility Solutions, vol. 12, pp. 76-85, 2022.
- [12]. Zhang, W., et al., "Real-Time Reconfigurable Road Dividers for Emergency Vehicle Access," Transportation Science, vol. 52, no. 2, pp. 139-151, 2021.
- [13]. Patel, K., et al., "Optimization of Emergency Vehicle Routes Using Dynamic Traffic Control Systems," International Journal of Advanced Engineering Research and Science, vol. 5, no. 4, pp. 117-124, 2019.
- [14]. Gupta, A., et al., "Smart Movable Barriers for Urban Traffic Control and Emergency Response," International Journal of Smart Grid and Clean Energy, vol. 9, no. 6, pp. 463-472, 2021.
- [15]. Reddy, K., et al., "AI-Based Emergency Vehicle Prioritization and Route Management," International Journal of Artificial Intelligence in Transportation, vol. 4, no. 1, pp. 34-47, 2020.
- [16]. Roy, A., et al., "Urban Traffic Management Using Smart Road Dividers and IoT Sensors," Journal of Urban Planning and Development, vol. 144, no. 3, pp. 145-156, 2018.
- [17]. Chen, L., et al., "Innovative Traffic Management System for Ambulance Mobility in Metropolitan Areas," Journal of Traffic and Transportation Engineering, vol. 37, no. 8, pp. 722-731, 2022.
- [18]. Zhang, H., et al., "The Impact of Smart Road Dividers on Emergency Response Time in Urban Areas," Urban Planning Review, vol. 45, pp. 29-40, 2021.
- [19]. Singh, V., et al., "Implementing Dynamic Road Divider Systems for Urban Emergency Vehicles," International Journal of Transportation Systems, vol. 11, no. 2, pp. 189-199, 2019.
- [20]. Verma, N., et al., "Smart Traffic Signals and Movable Barriers for Ambulance Routing in Urban Areas," Journal of Urban Mobility Research, vol. 23, pp. 45-56, 2020.
- [21]. Banerjee, S., et al., "Mobile and Smart Dividers for Ambulance Pathway Optimization," Automated Transport Systems, vol. 10, no. 3, pp. 201-212, 2018.
- [22]. Zhao, L., et al., "Machine Learning in Real-Time Traffic Management for Ambulance Prioritization," IEEE Transactions on Automation Science and Engineering, vol. 17, no. 5, pp. 1342-1353, 2020.
- [23]. Malik, R., et al., "Design and Implementation of Smart Infrastructure for Emergency Vehicle Prioritization," International Journal of Smart Infrastructure, vol. 18, pp. 61-75, 2021.
- [24]. Patel, R., et al., "Real-Time Dynamic Traffic Management for Emergency Services Using AI," Journal of Intelligent Transportation Systems, vol. 22, no. 7, pp. 521-533, 2021.
- [25]. Bansal, R., et al., "Smart Movable Dividers for Managing Urban Traffic Congestion," International Journal of Traffic Engineering and Management, vol. 15, no. 2, pp. 97-106, 2020.
- [26]. Chen, Y., et al., "Intelligent Traffic Signal Control for Prioritizing Emergency Vehicles," Journal of Urban Mobility and Traffic Engineering, vol. 24, no. 3, pp. 225-236, 2019.
- [27]. Liu, Z., et al., "Dynamic Lane Management Using Smart Dividers for Urban Traffic Flow," Transportation Research Part C: Emerging Technologies, vol. 115, pp. 36-48, 2020.
- [28]. Sharma, P., et al., "Using IoT and AI for Managing Emergency Vehicle Pathways in Urban Areas," International Journal of Automation and Control Engineering, vol. 6, no. 4, pp. 124-135, 2019

