

Automatic Room Lighting System using Aurdino

Kunjir Sakshi¹, Patil Sonali², Wagholikar Shruti³, Kamble Diksha⁴, Mashalkar Yogesh⁵

Students, Department of Electronics and Telecommunication Engineering¹⁻⁵

Vishweshwarayya Abhyantriki Padvika Mahavidyalaya, Almala, India

Abstract: In this project, the Automatic Room Lights using Arduino and PIR Sensor, where the lights in the room will switch on and off automatically when a human enters the room is made. Such Automatic Room Lights can be installed in garages, stairwells, restrooms, and other areas where we do not want continuous lighting but just when we are present. Also, with the help of an automatic room light control system, you won't have to worry about running out of electricity because the lights will turn off automatically when no one is in the room. So, in this DIY project, we used Arduino and a PIR Sensor to construct Automatic Room Lights.

Keywords: Automatic Room Lights, Arduino and a PIR Sensor.

I. INTRODUCTION

The Automatic Room Lights System with Arduino is a highly handy project since it eliminates the need to turn on and off switches every time you want to turn on the lights. The Arduino, PIR Sensor, and Relay Module are the primary components of the Automatic Room Lights project.

The PIR Sensor is the focal point of the three components because it is the primary device for detecting humans and human motion.

In reality, the Automatic Room Lights project is a key use of the PIR Sensor. A comparable principle is already in use in automatic toilet flush valves, hand dryers, and other products

Components Used in this project :

- Arduino UNO
- PIR Sensor
- Breadboard
- Relay 5V
- LDR – Light Dependent Resistor (photodiode)
- Resistor
- Bulb
- Power Supply

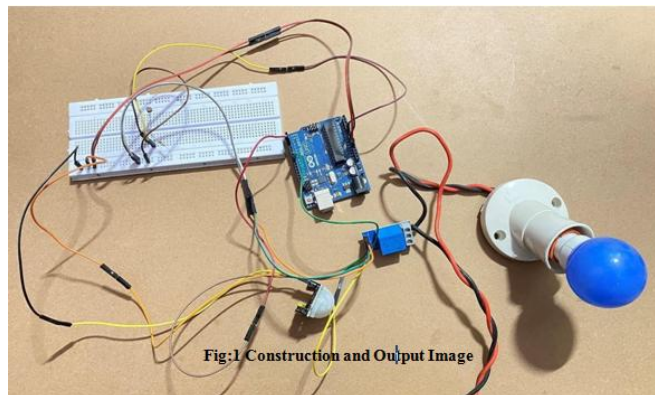

Fig:1 Construction and Output Image



II. CIRCUIT DIAGRAM OF AUTOMATIC ROOM LIGHTS USING ARDUINO

The following image shows the circuit diagram of the project implemented using Arduino UNO, PIR Sensor and a Relay Module

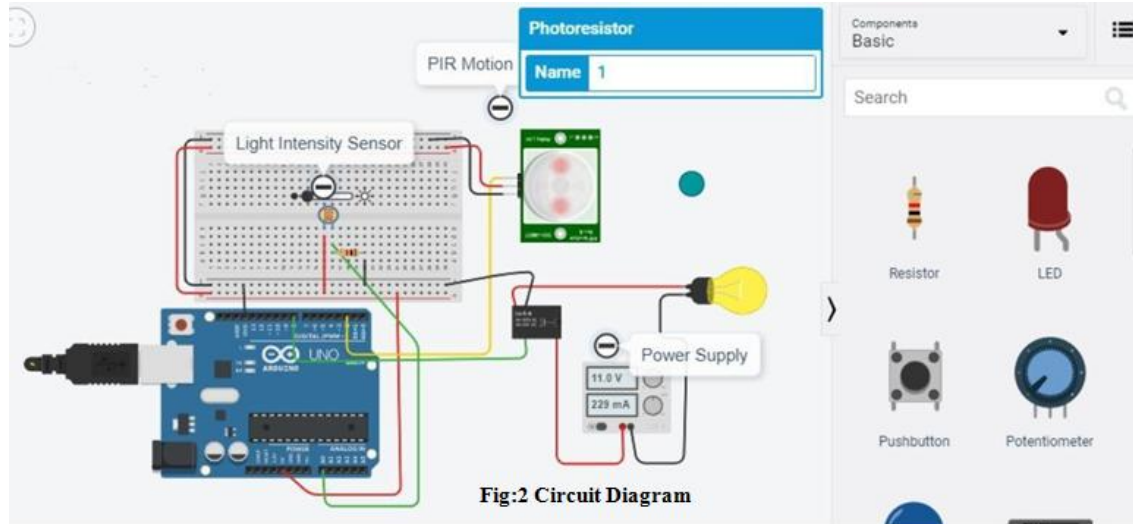

Fig:2 Circuit Diagram

III. COMPONENTS DESCRIPTION

PIR Sensor:

PIRs are essentially made of a pyroelectric sensor (shown below as the circular metal container with a rectangular crystal in the centre) that detects levels of infrared radiation. Everything emits some low-level radiation, and the higher the temperature, the more radiation is emitted. A motion detector's sensor is actually divided into two sections. The rationale for this is that we want to detect mobility (change) rather than average IR levels. The two sides are linked together in such a way that they cancel each other out. The output will swing high or low if one part sees more or less IR radiation than the other.



Figure: PIR Sensor

Relay:

A relay is a switch that is powered by electricity. It has a set of input terminals for a single or many control signals, as well as a set of operating contact terminals. The switch may have an unlimited number of contacts in various contact forms, such as make contacts, break contacts, or combinations of the two.





Figure: Relay

IV. CIRCUIT DESIGN

The Data OUT Pin of the PIR Sensor is linked to Arduino's Digital I/O Pin 8. An LED is attached to Arduino pin 13 to indicate whether the light is on or off.

The Relay Module's IN1 pin is wired to Arduino's Pin 9. A relay connects a light bulb to the power source. One bulb terminal is connected to one wire of the power source. The other end of the bulb is linked to the Relay Module's NO (Normally Open) contact.

The Relay's COM (Common) contact is linked to the other wire of the power source. When linking this section of the project, use caution.

V. CODE

```
// Automatic Room Lightning System
int LightSensorVal=0;//Input Sensor
int PIRSensorVal = 0; //Input S
int RelayOutputVal = 0; //Output Relay

void setup()
{
  pinMode(A0, INPUT); // Read the LDR sensor Value digital Input
  pinMode(2, INPUT); // Read the PIR motion sensor value
  digital Input pinMode(8, OUTPUT); // Write the Relay output value, digital output
  Serial.begin(9600);
}

void loop()
{
  LightSensorVal = analogRead(A0); PIRSensorVal =
  digitalRead(2); RelayOutputVal = 8;
  if (LightSensorVal < 600) {
  if (PIRSensorVal == HIGH)
  {
  digitalWrite(8, HIGH);
  delay(5000); // Wait for 5000 millisecond(s)
  } else {
  digitalWrite(8, LOW); delay(1000); // Wait for 1000 millisecond(s)
```



```
}  
} else { digitalWrite(8, LOW);  
Serial.println(LightSensorVal); delay(300);  
// Wait for 300 millisecond(s)  
}  
}
```

VI. WORKING

The Automatic Room Lights with Arduino and PIR Sensor is a simple project in which the lights in the room switch on automatically when a human motion is detected and stay on until the person leaves or there is no motion.

This project's operation is pretty easy, as explained here.

When there is no human movement, the PIR Sensor does not detect anyone and its OUT pin remains low. The PIR Sensor detects a shift in infrared radiation in the room as the person enters it.

As a result, the PIR Sensor's output becomes HIGH. Because the PIR Sensor's Data OUT is connected to Arduino's Digital Pin 8, once it gets HIGH, Arduino will activate the relay by turning the relay pin LOW

This will turn on the light. As long as there is movement in front of the sensor, the light remains on.

If the person falls asleep or leaves the room, the IR Radiation stabilizes, and the Data OUT of the PIR Sensor becomes LOW. As a result, the Arduino will switch off the relay and the room light will be turned off

Applications:

- Garage Lights
- Bathroom Lights
- Hand Dryers
- Toilet Flushers
- Security Lights

VII. RESULT



The automatic room light system is designed to Turn ON/OFF the light in a room based on the ambient light intensity.

VIII. CONCLUSION

The automatic room light system using Arduino has been successfully designed, develop and tested the system utilizes a light depends resistor ,(LDR) to sense . control the light using Arduino microcontroller

REFERENCES

[1]. TinkercadArduino Tutorials: Tutorials: Automatic Room Lightning System

[2].http://education.rec.ri.cmu.edu/content/electronics/boe/ir_sensor/1.html

[3] Automatic Room Light Controller with bidirectional visitor counter | VOL-I Issue-4| ISSN: 2395-4841
<http://www.ijictrd.net/papers/IJICTRDV1I4005.pdf>

[4].[http://www.digchip.com/datasheets/parts/datasheet/ 1_05/ CL100-pdf.php](http://www.digchip.com/datasheets/parts/datasheet/1_05/CL100-pdf.php)



- [5].[http://www.datasheetarchive.com/dlmain/Datasheets 3 12/174867.pdf](http://www.datasheetarchive.com/dlmain/Datasheets%203%2012/174867.pdf)
- [6].[https://www.fairchildsemi.com/datasheets/LM/LM78 05](https://www.fairchildsemi.com/datasheets/LM/LM7805)
- [7] www.ijictrd.net
- [8] www.slideshare.net
- [9] lib.chipresistor.ru

