

# Automation in Greenhouse using IoT

Mali Ovi<sup>1</sup>, Ostwal Sakshi<sup>2</sup>, Shingavi Akshada<sup>3</sup>, Rajhans Vaishnavi<sup>4</sup>, Rohit Ghadage<sup>5</sup>

Students, Department of Computer Engineering<sup>1,2,3,4</sup>

Assistant Professor, Department of Computer Engineering<sup>5</sup>

Shri Chhatrapati Shivaji Maharaj College of Engineering, Nepti, Ahmednagar, India

Affiliated to Savitribai Phule Pune University, Pune, Maharashtra

**Abstract:** *This work provides an IoT-based plant monitoring system for avoiding over-exploitation of resources, ensuring compact design with easy installation and the best environment for the plants to grow. This type of agricultural monitoring system provides environmental monitoring services that help the crop grow in good shape. The system offers the service of storing a database about the environment and soil information acquired from a wireless sensor network deployed in the planted area. Furthermore, it enables users to track environmental data regarding planted crops in real-time using any Internet-enabled device. Our project introduces automatic sunlight prevention and soil moisture control based on data received from the moisture and temperature sensors. The proposed work is implemented using a microcontroller, programmed accordingly to measure the temperature and moisture using respective sensors. It is well capable of controlling temperature by operating a fan, controlling a shade for blocking excess sunlight and controlling moisture by operating a watering device through a motor. The potential outcome of the project work can be used for greenhouse*

**Keywords:** Greenhouse, IoT, Internet-enabled device, Automation

## I. INTRODUCTION

According to the United Nations' Food and Agriculture Organization, food production must increase with 60 percent to be able to feed the growing population. Modern farms can sprawl for hundreds of acres. Rising prices of fertilizer and electricity, combined with regulations limiting irrigation are placing increasing demands on farmers to more precisely utilize their resources. Agriculture has been a leader for years in automation many industrial farms rely on harvesters guided by GPS. It is also an industry starving for more data. Fluctuations in rainfall or market prices can cause profits to quickly rise or plummet. Obtaining accurate, ongoing data on operations has historically also been a challenge. Between efforts to eat more food grown locally, a younger generation of farmers and cheaper component farming is getting an infusion of data and technology. As the concept of the 'Internet of Things' becomes increasingly prevalent, many systems are being devised to allow all manner of data to be gathered and analysed, and devices controlled via wireless data networks. The crop agriculture in greenhouse is higher affected by the surrounding conditions. The significant environmental factors for the quality and better productivity of the plants growth are temperature, relative humidity, Lighting and moisture of soil in greenhouse. Continuous monitoring of these factors gives relevant information pertaining to the individual effects of the various factors towards obtaining maximum crop production.

## II. ABOUT IOT

IoT or Internet of Things, refers to the collective network of connected devices and the technology that facilitates communication between devices and the cloud, as well as between the devices themselves. The Internet of Things integrates everyday "things" with the internet. Computer Engineers have been adding sensors and processors to everyday objects since the 90s. However, progress was initially slow because the chips were big and bulky. Generally an IoT system works through the real-time collection and exchange of data. An IoT system has basically three components: Smart Devices, IoT Application, A Graphical User Interface. The Future of IoT has the potential to be limitless.

### III. METHODOLOGY AND IMPLEMENTATION

The basic block diagram of IoT based greenhouse monitoring system using Arduino is shown in figure 1. The system is a greenhouse system in which there are four sensors. These sensors act as input to the micro controller system. The input feed provided to the micro controller is in the form of analog data. This data is converted by the controller into digital format. The data is shown on the LCD display and also on the android phone. Thus the monitoring of temperature, moisture and other parameters is done automatically. Once the parameter values are monitored they can be controlled by the embedded system which is built with coding. The android phone is operated by the user. The android application is used for controlling as per the user knowledge and required output.

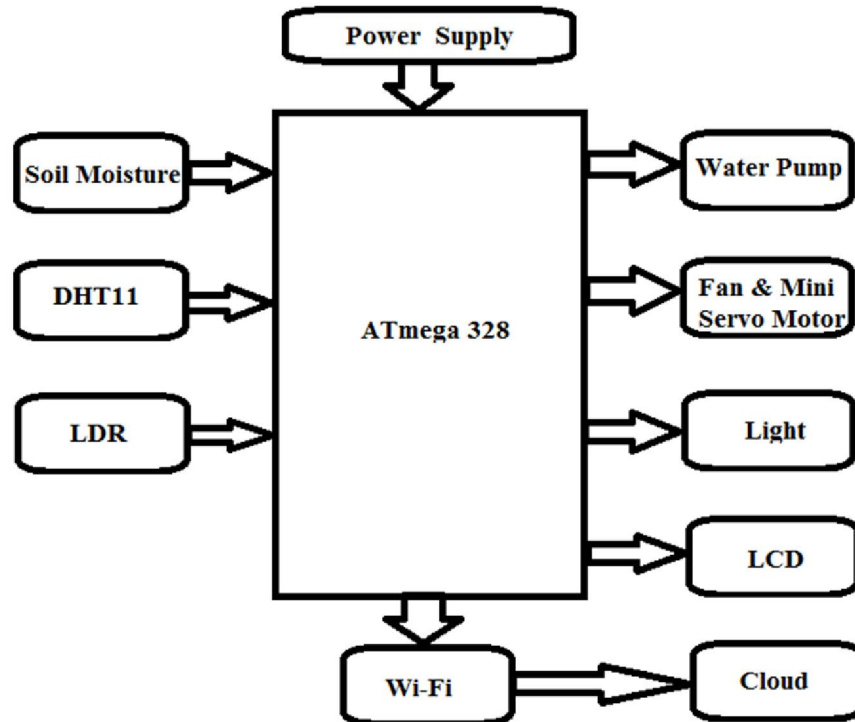

Fig 1: Block Diagram

### IV. SENSORS AND WI-FI MODULE

#### Soil Moisture Sensor

For acquiring water level in the soil, the electrical strength between the two probes of sensor is used. If the water content in the Soil is sufficient then the sensor output is high. When the land is dry, electrical conductivity is smaller and the output is low and so the motor operates.

#### Temperature and Humidity Sensor

We place temperature and humidity sensor inside the smart greenhouse to measure humidity and temperature. If the temperature exceeds beyond the limit set, then a fan will be automatically switched ON as a coolant to reduce the temperature. When it reaches the desired temperature the fan will be switched OFF automatically. But if the temperature decreases below the optimum temperature a bulb as a heater will be switched ON to set the temperature within the desired range. Humidity sensor is used for sensing the vapours in the air. The change in RH (Relative Humidity) of the surroundings would result in display of values. It uses a capacitive humidity sensor and a thermistor to measure the surrounding air.

#### LDR Sensor

LDR may be abbreviated as Light Dependent Resistor. If there is no sunlight in the greenhouse a signal is sent to the arduino by the sensor and arduino sends respective signal to the interface unit to activate lamps when the sunlight is at

a required rate the lamps are turned off by the arduino based on the sensor output. Therefore depending on the intensity of the sunlight, the program was published on Arduino to light on/off in the greenhouse. A photo-resistor is simply a variable resistor controlled by light.

### Wi-Fi Module

Wi-Fi Module is used to transmit information to the mobile phone. The Serial Port in the Wi-Fi Module is especially used to do this. The gateway node has been powered and initialized along with the network, in which will initialize the sensor node. The sensor node searches and transmits application for all networks accessible. The gateway identifies the request and connects the node and assigns the address of node to network. The sensor node collects data and sends to Arduino to the gateway of order. The Wi-Fi module ESP8266 is able to host an app or download Wi-Fi from another application Processor. ESP8266 provides a Wi-Fi connection to the microcontroller

### V. CONCLUSION AND FUTURE SCOPE

The advantage of Smart Greenhouse over conventional farming is that we are able to produce insecticide and pesticide free crops and create a climate for the proper growth of plants. Moreover this system can be installed by any individual in his house (Rooftop greenhouse), who do not have knowledge about farming. Since one can maintain any climatic condition in this type of Greenhouse, it is possible to cultivate any type of crop.

The smart greenhouse can be further upgraded in many ways and can be used in wide agricultural applications. It can be placed and operated in any of the environmental conditions to grow any kind of vegetation. Non- conventional energy sources such as solar panels, wind mills are used to supply power to the automatic greenhouse equipment and Peltier effect for cooling purpose. Soil-less farming can be performed to further improve the nutritional value. Integration of farming with IoT can make it much more efficient and profitable activity. Smart Greenhouse has a bright scope of future in agriculture field and it will create a revolution in the way the agriculture is carried out in India.

### REFERENCES

- [1]. "Smart Plant Monitoring and Controlling System for Greenhouse Application using IoT" by Tejaswini Kar, Serhii Bilyk (2023).
- [2]. Aditya Vishwakarma, Aniket Sahu, Nedeem Sheikh, Peeyoosh Payasi, Saurabh Rajput, Laxmi Srivastaava, "IoT Based Greenhouse Monitoring & Controlling System", IEEE, July 10-12, 2020.
- [3]. Pandu Naik, Sujana Sr, Amal Murali, Sagar Shetty, Sanjana Vasu, "Greenhouse Monitoring & Controlling Using IoT", IRJMETS, ISSN-2582- 5208, July 2021.
- [4]. Junyan Ma, Xingshe Zhou, Shining Li, Zhigang Li (2022), 'Connecting Agriculture to the Internet of Things through Sensor Networks 2011 IEEE International Conferences on Internet of Things, and Cyber, Physical and Social Computing