

RFID-Driven Shopping Cart using Arduino

Nagarjuna, Raghavendra Lokesh Chitragar, B Sai Abhishek, Yallappa Nagappa Hallur

Ballari Institute of Technology and Management, Ballari, Karnataka, India

nagarjunhskp@gmail.com, raghavendrachitragar27@gmail.com,

13saiabhishek@gmail.com, yallappahallir@gmail.com

Abstract: *Shopping cart using RFID & Arduino is an innovative solution that aims to enhance the shopping experience for customers. By incorporating Radio Frequency Identification (RFID) technology and Arduino microcontrollers, this shopping cart system enables seamless and efficient shopping. RFID technology involves the use of small electronic tags or labels that contain unique identification information. These tags are attached to the products, and the cart is equipped with RFID readers. When a product is placed in the cart, the RFID reader detects the tag and automatically adds the item to the cart's digital inventory..*

Keywords: Shopping cart

I. INTRODUCTION

Shopping cart using RFID & Arduino is an innovative solution that aims to enhance the shopping experience for customers. By incorporating Radio Frequency Identification (RFID) technology and Arduino microcontrollers, this shopping cart system enables seamless and efficient shopping.

RFID technology involves the use of small electronic tags or labels that contain unique identification information. These tags are attached to the products, and the cart is equipped with RFID readers. When a product is placed in the cart, the RFID reader detects the tag and automatically adds the item to the cart's digital inventory.

The Arduino microcontroller acts as the brain of the shopping cart, processing the information received from the RFID reader and updating the cart's inventory in real-time. This allows customers to keep track of the products they have selected, eliminating the need for manual item scanning or keeping a mental inventory.

Additionally, the shopping cart can provide helpful features such as price comparison, product recommendations, and personalized promotions. With the help of a connected smartphone application, customers can access this information and make informed decisions while shopping.

The benefits of a shopping cart using RFID and Arduino are numerous. It saves time for both customers and store employees, as the checkout process becomes more streamlined. It also reduces the chances of errors in product selection and pricing. Moreover, it provides an opportunity for retailers to gather valuable data on customer preferences and shopping habits, enabling them to improve their offerings and tailor promotions accordingly.

In the dynamic realm of retail, the convergence of technology and consumer expectations has catalyzed a wave of innovation aimed at enhancing the shopping experience. One such innovation gaining momentum is the RFID-driven smart shopping cart, powered by Arduino technology. This introduction serves as a gateway into understanding the transformative potential of RFID-driven smart shopping carts and their implementation using Arduino.

Radio-Frequency Identification (RFID) technology has emerged as a game-changer in retail, offering seamless item tracking and inventory management capabilities. By leveraging RFID tags embedded in products and integrating RFID readers into shopping carts, retailers can unlock a myriad of benefits, ranging from streamlined checkout processes to personalized shopping experiences.

At the heart of this innovation lies Arduino, an open-source electronics platform renowned for its versatility and accessibility. Arduino provides the foundation for building RFID-driven smart shopping carts, empowering retailers with the flexibility to customize and tailor the technology to their specific needs.

This introduction sets the stage for exploring the key components and functionalities of RFID-driven smart shopping carts using Arduino. From automatic item detection to real-time product information retrieval and personalized recommendations, the possibilities are boundless.

Furthermore, this introduction highlights the broader implications of implementing RFID-driven smart shopping carts, including enhanced operational efficiency, improved inventory management, and elevated customer satisfaction. By embracing this innovative technology, retailers can position themselves at the forefront of the industry, driving profitability and differentiation in an increasingly competitive market landscape.

In the subsequent sections, we delve deeper into the intricacies of RFID technology, Arduino integration, and the transformative potential of RFID-driven smart shopping carts. Through practical insights and theoretical foundations, readers will gain a comprehensive understanding of how this groundbreaking technology is reshaping the future of retail.

In essence, RFID-driven smart shopping carts represent more than just a technological advancement; they signify a paradigm shift in the way retailers engage with customers and manage their operations. As we embark on this journey, the possibilities are limitless, and the opportunities for innovation are boundless. Welcome to the future of retail – welcome to the world of RFID-driven smart shopping carts powered by Arduino.

1.1 OBJECTIVES OF PROJECT

- Streamline the shopping experience: The primary objective is to make the shopping process more efficient and convenient for customers. By automating the inventory tracking and checkout process, customers can save time and effort while shopping.
- Improve inventory management: The smart shopping cart system aims to provide real-time inventory tracking, ensuring accurate stock management for retailers. This helps in reducing stockouts, optimizing replenishment processes, and improving overall inventory control.
- Enhance customer engagement: By providing personalized recommendations and promotions, the smart shopping cart aims to engage customers and enhance their shopping experience. This can lead to increased customer satisfaction and loyalty.
- Enable data-driven decision-making: The system collects valuable data on customer preferences, shopping habits, and product demand. This data can be analyzed to gain insights into customer behaviour, optimize store layouts, improve product offerings, and drive better business decisions.
- Reduce errors and losses: With RFID technology, the smart shopping cart minimizes errors in product scanning and pricing, reducing the chances of incorrect charges or missed items. This helps in reducing losses for both customers and retailers.
- Enable seamless integration with existing systems: The smart shopping cart system should be designed to seamlessly integrate with existing retail systems such as point-of-sale (POS) systems and inventory management software. This ensures smooth implementation and compatibility with the existing infrastructure.

II. LITERATURE SURVEY

Paper [1] describes the implementation of shopping cart using radio frequency identification using the RFID sensors, Arduino microcontroller, Bluetooth module, and Mobile application. Where the mobile is connected to the shopping cart and the application is already installed, the data is shared using the Bluetooth from the Arduino microcontroller and the mobile then with the server.

Paper [2] "Intelligent shopping cart using BOLT based on IOT". IOT kit consists of barcode scanner, LCD display, Bolt ESP8266. The broad clarification of its process is, when consumer takes an item and put inside the trolley, that time barcode scanner scans the item barcode and value as well as gain to show into the digital display panel. Later than consumer concluded their purchasing and the bill is sent to the counter section.

Paper [3] "Smart Trolley with Instant Billing to Ease Queues at shopping malls using ARM7 LPC2148. This is based on arm7 microcontroller fitted with an LCD and RFID scanner and a wireless technology called zigbee. The LCD used is a 16x2 and zigbee modules make the wireless network to work even at long distance due to its wide range, the RFID scanner scans the product's unique code and its price. And it gets displayed on the LCD screen.

Paper [4] EM-18 RFID scanner module has been used. It uses a RFID reader which will read 125 kHz tags. So, it will be known as a low frequency RFID reader. The RFID Readers here used are big tags with range of 125KHZ which can

be detected by EM-18 Module. It shows the real time billing and you can even delete the item you don't want by pressing the delete button. In this author has used ARDUINO Uno which one of the cheapest and most efficient models in the market. It contains everything required to support the microcontroller merely connect it to a laptop (or applicable wall power adapter) with a USB cable or power it with an AC-to-DC adapter or battery to get started.

Paper [5] Framework is utilized to ease lines in shopping centre by utilizing RFID module. The RFID reader will peruse the RFID Tag set on the item when the item falls in the trolley. In the event that, the client needs to expel any item then he should expel that item from the trolley. The LCD will show the subtitles of the expelled item like name, cost and the absolute bill and with the help of Xampp server the bill will be send to the cashier.

Paper [6] describes the implementation of a Smart Shopping Cart using ZigBee networks. The reliable and cost-efficient system design also ensures detection of deception. Thus, the smart system attracts both the buyers and sellers and ZigBee acts like Xampp server but is more reliable.

Paper [7] Automation of shopping cart using RFID module and ZIGBEE module, in this system, RFID tags are used instead of barcodes. These RFID tags will be on the product. When the customer takes a product and places it in the trolley, the trolley will contain an RFID reader which will sense the RFID tag which is present on the product. Thus displays the product price on the LCD display. Like this, the process continues. Along with it, comes a ZIGBEE transmitter in the trolley, which transfers data to the main computer. The ZIGBEE receiver is placed near the main computer which receives the data from transmitter.

Paper [8] designs a shopping cart by taking inspiration from a shopping basket which is under development by Panasonic, in which each item is tagged using UHF RFID [range: 916-924 MHz] Two Circular Polarized (CP) Patch antennae used to read RFID tags in different orientations. CSL 468 RFID reader used having 16 ports and scan speed of 300 tags/sec Paper

[9] Smart Shopping Cart with Automatic Billing System through RFID and ZigBee, this application creates an automated central bill system for the mall. Customers can pay their bill through credit/debit cards. Zigbee and RFID used for in it.

Paper [10] This framework is utilized as a part of spots, for example, general stores. It can help in diminishing labor and in making a superior shopping background for the clients. Rather than influencing the clients to hold up in a long line while looking at, the framework robotizes the charging procedure. The client can likewise track the subtle elements of the acquired things and additionally the present bill sums on the screen.

III. IMPLEMENTATION AND METHODOLOGY HARDWARE AND SOFTWARE REQUIRED

3.1 SOFTWARE

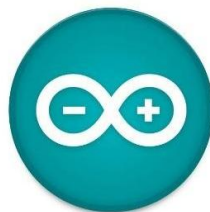

Fig.3.1.1 Arduino IDE Logo

[7] The Arduino IDE is an open-source software, which is used to write and upload code to the Arduino boards. The IDE application is suitable for different operating systems such as Windows, Mac OS X, and Linux. It supports the programming languages C and C++. Here, IDE stands for Integrated Development Environment.

The program or code written in the Arduino IDE is often called as sketching. We need to connect the Genuine and Arduino board with the IDE to upload the sketch written in the Arduino IDE software. The sketch is saved with the extension '.ino.' and user community that designs and manufactures single board microcontrollers and microcontroller kits for building digital devices. It is hardware products are licensed under a CC BY-SA license, while software is licensed under the GNU Lesser General Public License (LGPL) or the GNU General Public License (GPL), permitting

the manufacture of Arduino boards and software distribution by anyone. Arduino boards are available commercially from the official website or through authorized distributors.

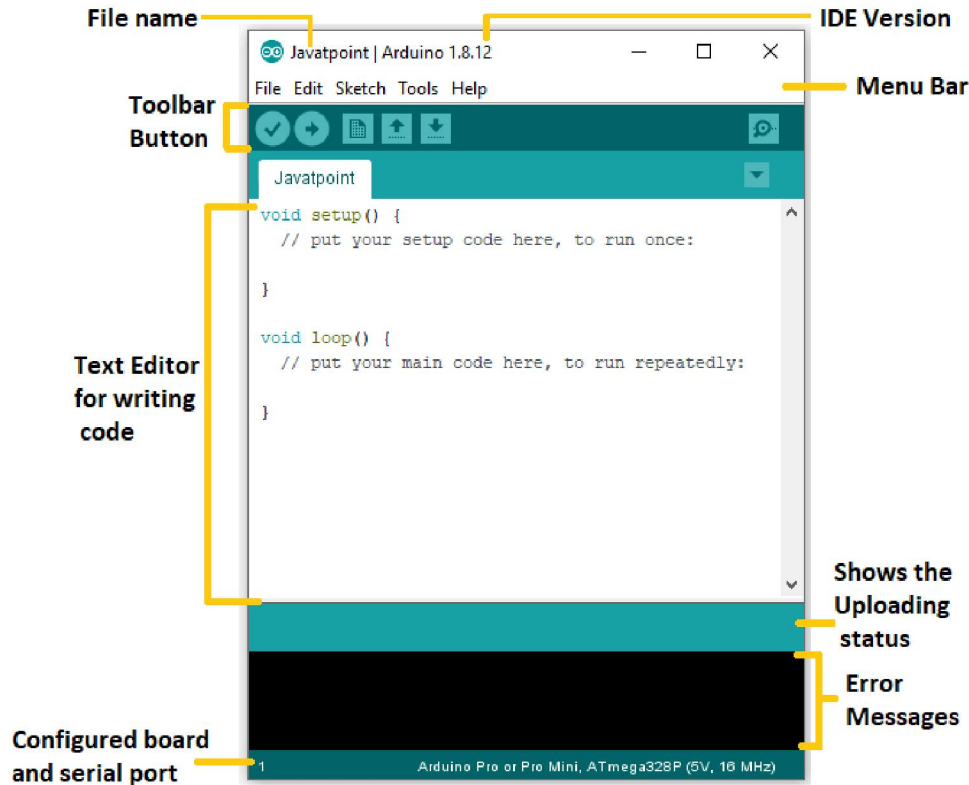

Fig.3.1.2 Arduino IDE Window

Arduino board designs use a variety of microprocessors and controllers. The boards are equipped with sets of digital and analog input/output (I/O) pins that may be interfaced to various expansion boards ('shields') or breadboards (for prototyping) and other circuits. The boards feature serial communication interfaces, including Universal Serial Bus (USB) on some models, which are also used for loading programs. The microcontrollers can be programmed using the C and C++ programming languages, using a standard API which is also known as the Arduino language, inspired by the Processing language and used with a modified version of the Processing IDE. In addition to using traditional compiler toolchains, the Arduino project provides an integrated development environment (IDE) and a command line tool developed in Go.

3.2 HARDWARE

Components Used:

- 3.2.1 Arduino nano
- 3.2.2 16x2 LCD Display
- 3.2.3 EM-18 Module
- 3.2.4 Push Button
- 3.2.5 Red LED
- 3.2.6 Green LED
- 3.2.7 Buzzer
- 3.2.8 RFID Tag
- 3.2.9 Zero PCB
- 3.2.10 Power supply

3.2.1 Arduino nano

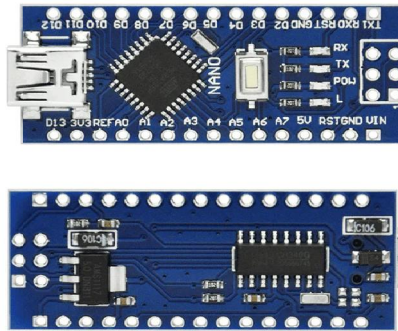

Fig: 3.2.1 Arduino nano

The Arduino Nano is an open-source breadboard-friendly microcontroller board based on the Microchip ATmega328P microcontroller (MCU) and developed by Arduino.cc and initially released in 2008. It offers the same connectivity and specs of the Arduino Uno board in a smaller form factor.

3.2.1.1 Arduino Nano Pin Configurations

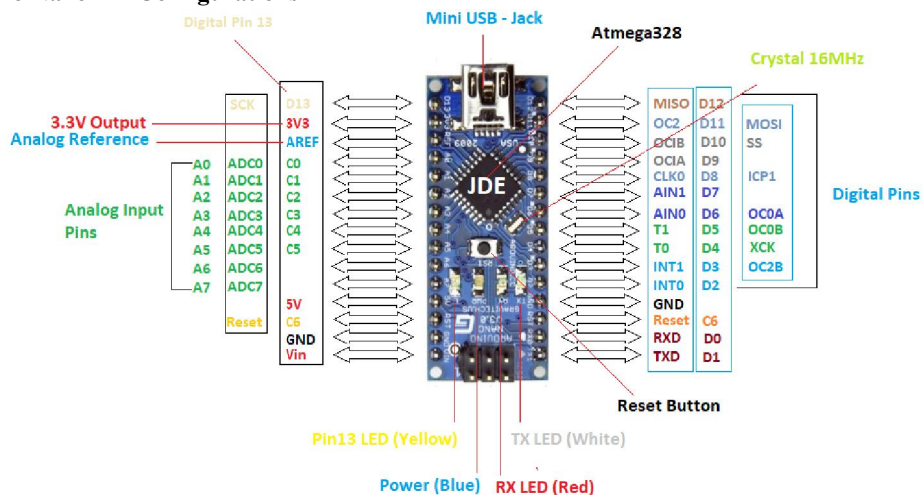

Fig :3.2.1.1 Arduino Nano Pin Configurations

The Arduino Nano is equipped with 30 male I/O headers, in a DIP-30-like configuration, which can be programmed using the Arduino Software integrated development environment (IDE), which is common to all Arduino boards and running both online and offline. The board can be powered through a type-B mini-USB cable or from a 9 V battery.

3.2.2 16x2 lcd display



Fig :3.2.2 16x2 LCD Display

A 16×2 LCD display is a liquid crystal display that can show 16 characters in each of its two rows, providing a total of 32 characters of information. It’s commonly used to display alphanumeric information in various electronic devices. A 16×2 LCD display works by controlling the liquid crystals to either block or allow light to pass through, creating characters and symbols on the screen. It’s controlled by sending data and commands to its controller, which in turn manages the display of information.

A standard 16×2 LCD display has 16 pins, typically organized into two rows of eight pins each. These pins are used for power supply, data communication, and control signals. The contrast control adjusts the contrast between the text and the background on the LCD screen. By changing the voltage across the liquid crystals, you can control the readability of the displayed content.

3.2.3 EM-18 MODULE

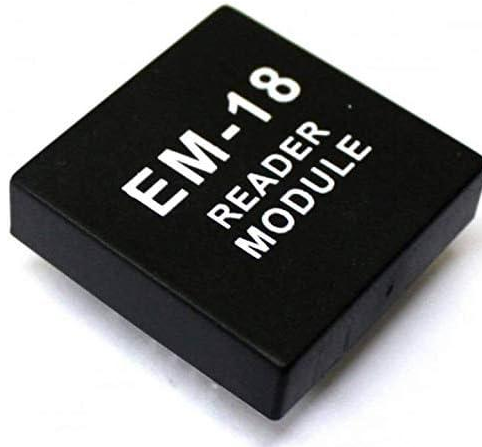

Fig: 3.2.3 Em-18 Module

This module directly connects to any microcontroller UART or through an RS232 converter to a PC. It gives UART/Wiegand26 output. This RFID Reader Module works with any 125 kHz RFID tags. In our projects and Tutorials, we are going to use this module. 5VDC through USB (External 5V supply will boost the range of the module) Current: <50Ma Operating Frequency: 125Khz Read Distance: 10cm. Size of RFID reader module: 32mm(length) * 32mm(width) * 8mm(height)

Applications

RFID is used in many applications like an attendance system in which every person will have their separate RFID tag which will help identify the person and their attendance.

RFID is used in many companies to provide access to their authorized employees.

It is also helpful to keep track of goods and in an automated toll collection system on the highway by embedding Tag (having unique ID) on them.

3.2.4 Push button



Fig: 3.2.4 Push Button

DOI: 10.48175/IJARSCT-18519

Push button switches (also referred to as pushbutton switches) are electrical actuators that, when pressed, either close or open the electrical circuits to which they are attached. They are capable of controlling a wide range of electronic gadgets. These switches take the form of a button or a key. A Push Button switch is a type of switch which consists of a simple electric mechanism or air switch mechanism to turn something on or off.

Depending on model they could operate with momentary or latching action function. The button itself is usually constructed of a strong durable material such as metal or plastic. Push Button Switches come in a range of shapes and sizes. We have a selection of push button switches here at Herga. Push button switches are used throughout industrial and medical applications and are also recognisable in everyday life For uses within the Industrial sector, push buttons are often part of a bigger system and are connected through a mechanical linkage. This means that when a button is pressed it can cause another button to release.

3.2.5 LED



Fig: 3.2.5 LED

The major uses of LED (Light Emitting Diodes) are to illuminate objects and even places. Its application is everywhere due to its compact size, low consumption of energy, extended lifetime, and flexibility in terms of use in various applications. Applications and uses of LEDs can be seen in: TV Backlighting. LEDs have also given rise to new types of displays and sensors, while their high switching rates are useful in advanced communications technology with applications as diverse as aviation lighting, fairy lights, strip lights, automotive headlamps, advertising, general lighting, traffic signals, camera flashes, lighted on LED datasheets. Typically, the forward voltage of an LED is between 1.8 and 3.3 volts. It varies by the color of the LED.

A LED typically drops around 1.7 to 2.0 volts, but since both voltage drop and light frequency increase with band gap, a blue LED may drop around 3 to 3.3 volts. According to the U.S. Department of Energy, LED light bulbs use at least 75 percent less energy than incandescent bulbs. A typical LED light bulb uses about 10 watts, according to EnergySage, compared to about 60 watts for most incandescent bulbs. between 10 to 30 mA Like signal diodes, LEDs are characterized by their forward voltage and forward current. Typically, the forward voltage is between 1.2 to 3.6 V, and the forward current is between 10 to 30 mA. Electric current is the flow of electrons through a complete circuit of conductors. It is used to power everything from our lights to our trains.

3.2.6 Buzzer



Fig: 3.2.6 Buzzer

An audio signaling device like a beeper or buzzer may be electromechanical or piezoelectric or mechanical type. The main function of this is to convert the signal from audio to sound. Generally, it is powered through DC voltage and used in timers, alarm devices, printers, alarms, computers, etc. Based on the various designs, it can generate different sounds like alarm, music, bell & siren.

There are many ways to communicate between the user and a product. One of the best ways is audio communication using a buzzer IC. So during the design process, understanding some technologies with configurations is very helpful. The pin configuration of the buzzer is shown below. It includes two pins namely positive and negative. The positive terminal of this is represented with the '+' symbol or a longer terminal. This terminal is powered through 6Volts whereas the negative terminal is represented with the '-' symbol or short terminal and it is connected to the GND terminal.

These buzzers were invented by manufacturers of Japanese & fixed into a broad range of devices during the period of 1970s – 1980s. So, this development primarily came due to cooperative efforts through the manufacturing companies of Japanese. In the year 1951, they recognized the Application Research Committee of Barium Titanate that allows the corporations to be cooperative competitively & bring about numerous piezoelectric creations.

3.2.7 RFID Tag



Fig: 3.2.7 RFID Tag

RFID cards are physical access cards that use radio frequency identification to grant access to a particular area or individual. They work by emitting a signal that can be detected by an RFID reader, granting access to the cardholder.

RFID cards are a more secure alternative to traditional passwords, as they are difficult to replicate and do not require manual input. This makes them ideal for physical access and identity management applications, where security is paramount.

“The future is about the Internet of Things, and RFID is a key technology that will enable it. It will allow us to connect the physical world to the digital world in new and innovative ways

RFID cards work by emitting a radio signal that a scanner can read. The scanner emits a signal that the card receives, which then responds by transmitting the information stored on the card. This process allows the card to be read without having to be physically touched by the scanner.

There are two main ways an RFID card can be used: passive and active.

A passive RFID card doesn't have a battery, so it relies on the reader to provide power. This card type is generally used for access control.

An active RFID has a battery to broadcast a signal farther away from the reader. This card type is often used for tracking, such as supply chain management or asset tracking.

3.2.8 Zero PCB

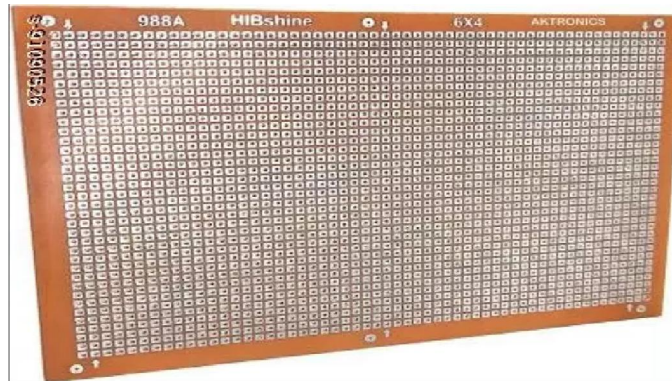

Fig: 3.2.8 Zero PCB

A zero PCB (printed circuit board) refers to a type of board used in electronics that does not have any printed or pre-defined circuits on it. It's essentially a bare board, also known as a general-purpose PCB, perfboard, or breadboard.

These boards are perforated with tiny holes, each of which is electrically isolated from the others. They are useful for prototyping as you can build a circuit on them by inserting components into the holes and then connecting them with wire, instead of having a pre-defined path for the current to follow.

Zero PCBs allow engineers and hobbyists to create custom circuits and test them out before moving to a more permanent solution like a fully printed circuit board. The term "zero" in this context means that there are no predefined or "printed" tracks or connections on the board; the user defines all connections.

This PCB has multiple thin layers stacked together, enabling complex circuits. The material used depends on the application, ranging from fiberglass to advanced materials like ceramic or Teflon.

Material used in the construction of Zero PCB Board

To construct a Zero PCB Board, different materials are needed. These must be of high quality and have certain properties to guarantee the board works correctly. Here is a list of the materials usually used for this board:

These materials form a layered structure that forms the Zero PCB Board. Nowadays, modern boards may also have other materials like ceramics or plastics.

When constructing a board, it must meet industry standards for thickness, surface finish, and solderability. By using the right materials and following production standards, manufacturers make high-quality boards.

To select or plan a circuit assembly for electronics applications, you must understand the material composition of the Zero PCB Board. Choosing strong materials with appropriate electrical properties ensures system reliability and durability.

3.2.9 Jumper wires



Fig: 3.2.9 Jumper Wires

A jumper wire is an electric wire that connects remote electric circuits used for printed circuit boards. By attaching a jumper wire on the circuit, it can be short-circuited and short-cut (jump) to the electric circuit.

Jumper wires are essential components used in electronics and prototyping to establish electrical connections between various electronic components such as breadboards, microcontrollers, sensors, and other devices. They consist of thin, insulated wires with connectors or pins at each end.

Jumper wires come in different types and sizes, such as male-to-male, male-to-female, and female-to-female, to accommodate various connection needs. Male connectors have exposed pins, while female connectors have receptacles to receive the male pins.

These wires allow for quick and temporary connections without the need for soldering or permanent wiring. They enable easy experimentation, circuit modifications, and prototyping by providing a flexible and versatile means of connecting different components together.

3.2.10 POWER SUPPLY



Fig: 3.2.10 Power Supply

Hi-Waote 9V Battery is the most commonly used and portable 9V battery. It is non-rechargeable and is a high capacity and low-cost solution for many electronic devices. It is based on Zinc Carbon Chemistry and can be used easily replaced if discharged just like any standard AA and AAA batteries. The battery can be used to power LEDs, Toys, Flashlight and Torch, electronic equipment like multimeter, wall clocks, or other devices with a 9V system. A battery snap connector is generally used to connect it with a breadboard.

SPECIFICATIONS

- Nominal Voltage(V): 9V
- Battery Type: Zinc Carbon battery
- Dimension: 26.5mm x 48.5mm x 17.5mm
- System: Zinc Carbon
- Discharge Resistance (Ohms): 620
- Cut-off Voltage(V): 5.4
- Discharge Tie: 270Hm, 9 Hrs
- Jacket: Metal
- Operating Temperature Range (deg. C): -20 to +85

3.3 CIRCUIT DIAGRAM

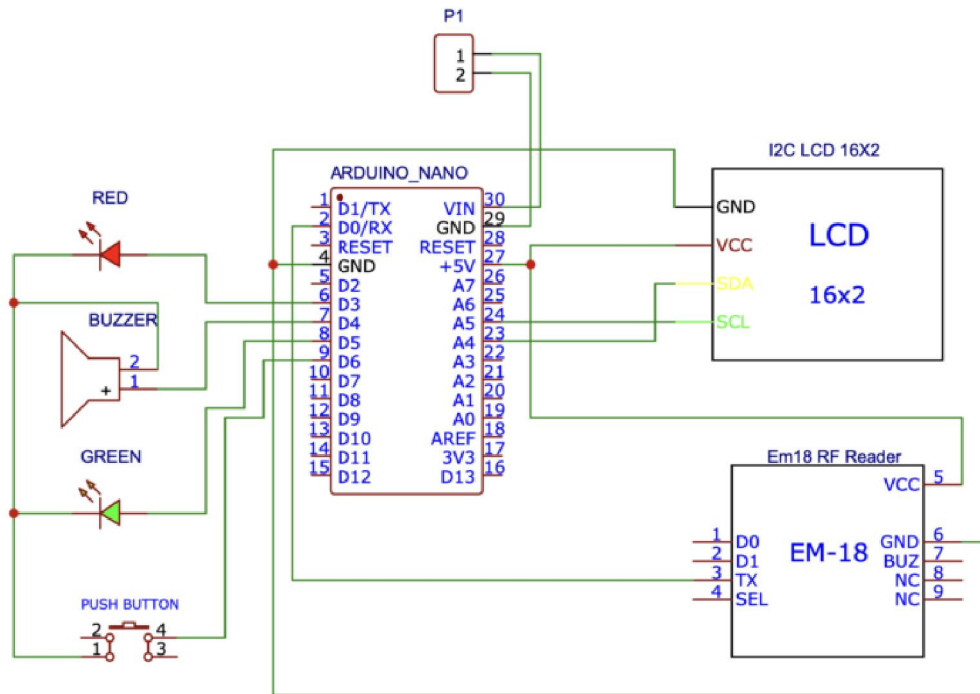

Fig: 3.3 Circuit Diagram

Working

- **RFID Tagging:** Each item in the store is tagged with an RFID tag containing unique identification information.
- **RFID Reader:** An RFID reader is integrated into the shopping cart, allowing it to read the RFID tags on the items placed inside.
- **Item Identification:** The Arduino microcontroller processes the data received from the RFID reader to identify the items in the cart.
- **Cart Display:** A display screen is incorporated into the shopping cart to show the list of items, their prices, and any other relevant information.
- **Inventory Management:** The system keeps track of the inventory, updating it in real-time as items are added or removed from the cart.

3.4 SCHEMATIC DIAGRAM OF CONNECTION

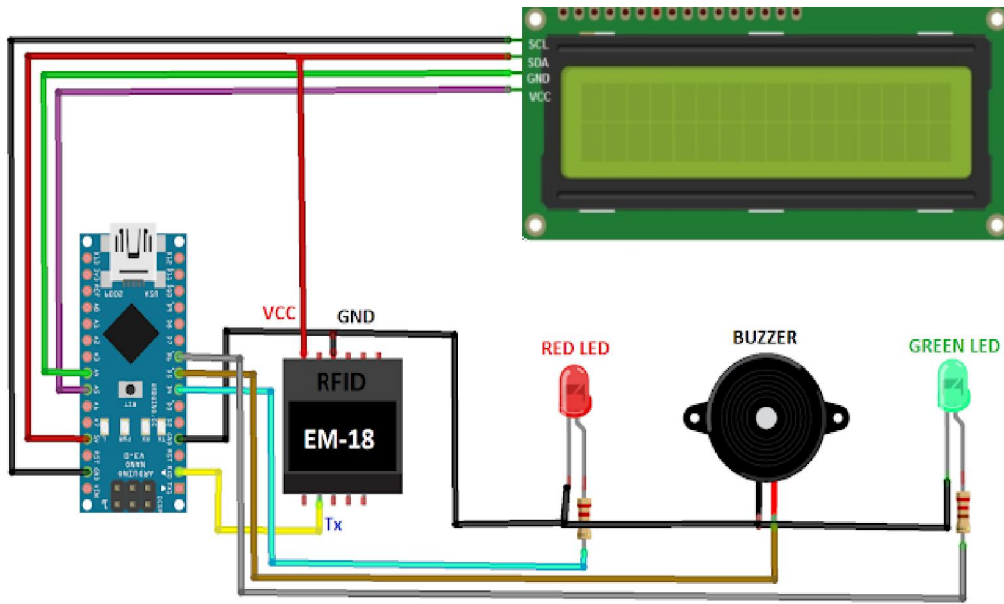
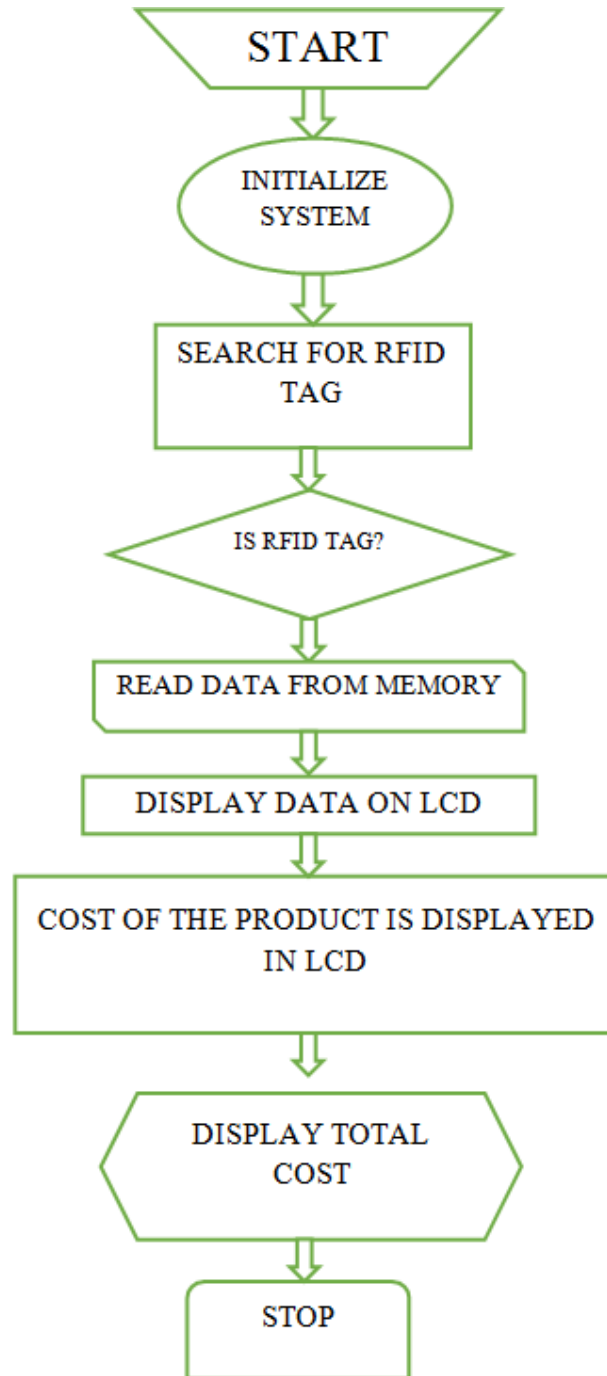
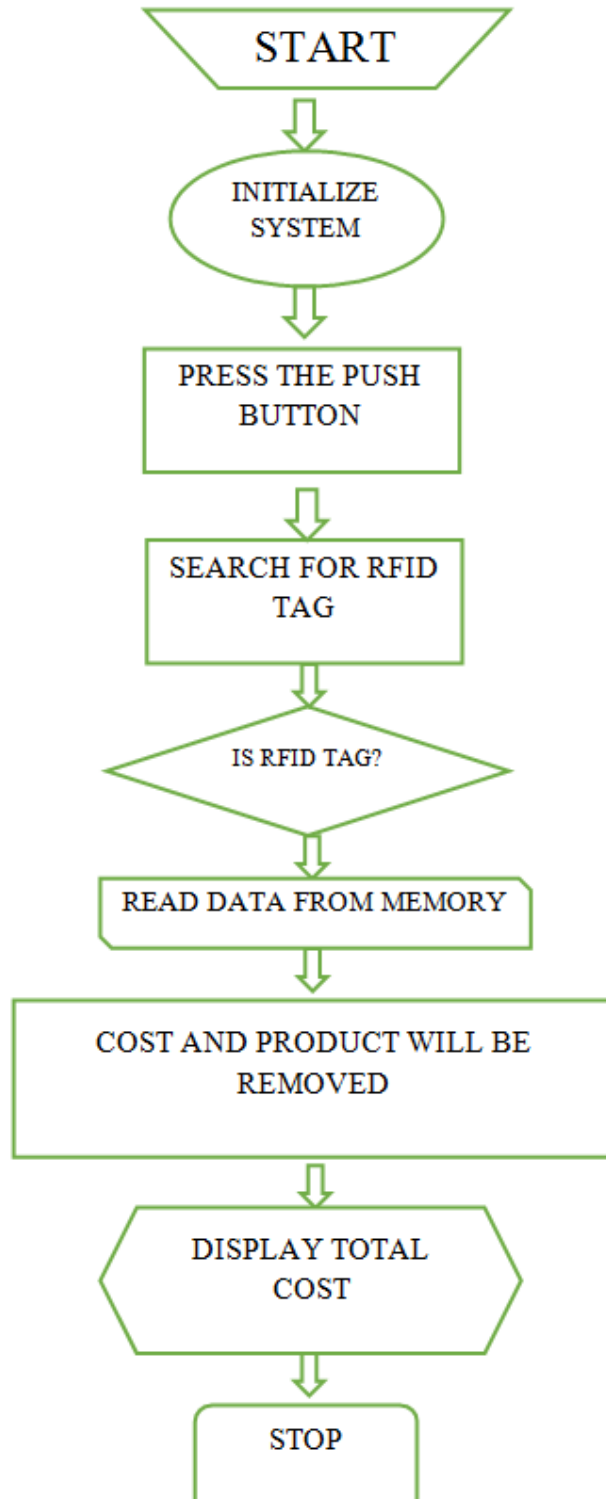

Fig: 3.4 Schematic Diagram of Connection

3.5 ROADMAP FOR ADDING ITEMS



3.6 ROADMAP FOR REMOVING ITEMS



VI. RESULTS AND DISCUSSION



Fig 4.1 Automatic Bill Shopping cart



Fig 4.2 Scanning Tags to add Items

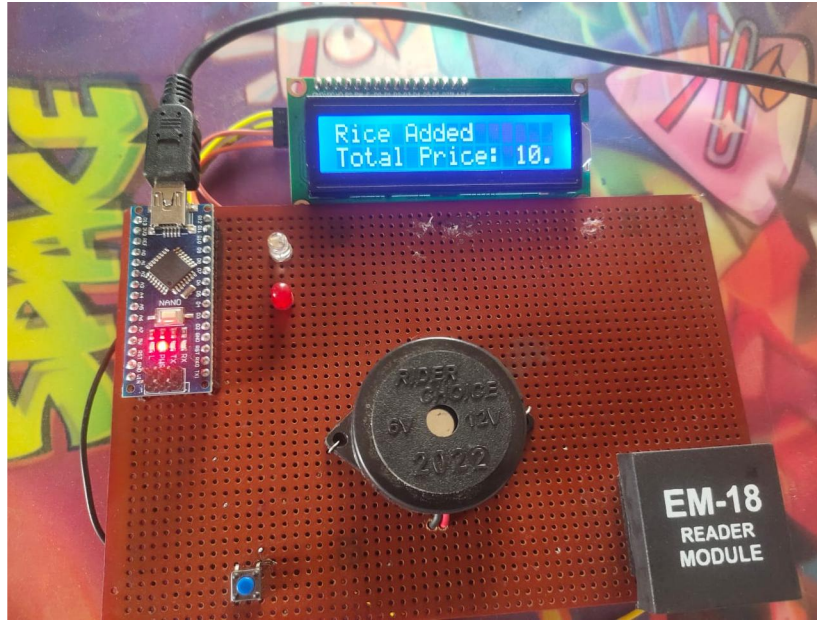

Fig 4.3 Item Added

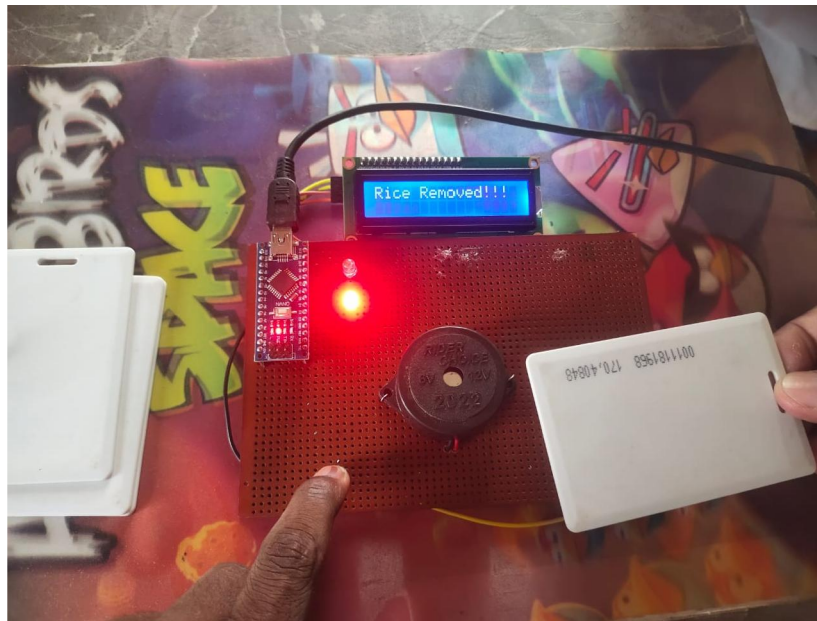

Fig 4.4 Scanning Tag to Remove items

Imagine a special way of paying for things in stores. Instead of waiting in long lines to pay, you can use a system that's really quick and accurate. This system uses small tags called RFIDs that are attached to every product in the store.

Here's how it works:

No More Long Lines: You won't have to stand in line for a long time because this system makes paying super-fast.

No Mistakes: With these special tags on products, there's almost no chance of mistakes in how much you're charged.

Faster Checkout: Using this system, stores can ring up your purchases much quicker than before.

Saves Money: Stores might need fewer workers, which means they can save money and maybe even charge you less.

Easy to Use: It's simple for stores to set up and use. The equipment needed isn't expensive either.

Here's how it would work in a store:

Every item in the store has a small tag on it.

As you pick out items and scan the tag, machine add it in to cart and it will display “Item name Added”.

The total amount you need to pay is shows in the Display.

The machine calculates how much you added and shows it on a screen.

If you need to remove any item you can scan the tag again by press and hold push button and remove the item and it will display “Item name Removed”

-if the item is not in added item it will show “Not in cart”.

You can pay using whatever method you like.

This smart system is really flexible and can be used in lots of different places. It's a great way for stores to make shopping easier for you and for them to save money too.

V. APPLICATIONS

- **Automated Inventory Management:** RFID tags on products can be scanned automatically as they are placed into the cart, updating the store's inventory in real-time. This helps retailers keep track of stock levels and minimize manual inventory checks.
- **Efficient Checkout Process:** By automatically scanning RFID tags, the checkout process becomes faster and more streamlined. Customers can simply pay and go without the need for individual item scanning, reducing waiting times at the checkout counters.
- **Personalized Shopping Experience:** RFID tags can be linked to customer profiles, allowing retailers to offer personalized recommendations and promotions based on past purchase history. This enhances customer engagement and loyalty.
- **Loss Prevention:** RFID technology can help prevent theft by alerting store staff if an item is removed from the cart without being scanned. Additionally, RFID-enabled exit gates can detect unpaid items, reducing shrinkage.
- **Assistance for Special Needs Customers:** RFID-driven shopping carts can be designed with features to assist special needs customers, such as navigation aids for visually impaired individuals or voice prompts for those with cognitive impairments.
- **Queue Management:** RFID sensors at checkout lanes can monitor the number of RFID-enabled carts approaching, enabling stores to open additional checkout counters as needed to reduce waiting times during peak hours.
- **Location-based Promotions:** By tracking the movement of RFID-enabled carts within the store, retailers can push location-based promotions or discounts to customers' smartphones, encouraging impulse purchases.
- **Data Analytics:** RFID data collected from shopping carts can provide valuable insights into customer behavior, such as popular products, dwell times in different store sections, and peak shopping hours. Retailers can use this data to optimize store layouts and marketing strategies.
- **Contactless Payments:** Integrated RFID technology can facilitate contactless payments, allowing customers to pay for their purchases using RFID-enabled cards or mobile.

5.1 ADVANTAGES

- **Efficiency:** RFID-driven shopping carts streamline the shopping process by automatically scanning items as they are placed into the cart. This reduces the need for manual scanning at checkout counters, saving time for both customers and staff.
- **Accuracy:** RFID technology ensures accurate product identification, reducing errors in the checkout process. This helps prevent undercharging or overcharging for items and improves overall transaction accuracy.
- **Inventory Management:** With RFID tags on products and RFID readers in the shopping cart, retailers can maintain real-time inventory visibility. This enables better inventory management, reducing instances of stockouts and overstocking.

- Enhanced Customer Experience: RFID-driven carts provide a more convenient and seamless shopping experience for customers. They can quickly locate items, access product information, and complete their purchases without waiting in long checkout lines.
- Loss Prevention: RFID technology can help prevent theft and reduce shrinkage by alerting store staff to any discrepancies between items in the cart and items scanned for purchase. This improves security and minimizes losses for retailers.
- Data Analytics: RFID-driven shopping carts generate valuable data on customer behaviour, such as popular products, peak shopping times, and average transaction values. Retailers can use this data to make informed business decisions and tailor their marketing strategies accordingly.
- Integration: Arduino Nano provides a flexible platform for integrating RFID technology into shopping carts. It allows for customization and scalability, enabling retailers to adapt the system to their specific needs and requirements.
- Cost-Effectiveness: RFID technology has become more affordable in recent years, making it a cost-effective solution for retailers looking to improve their operations. Arduino Nano offers a cost-effective microcontroller platform for implementing RFID-driven shopping carts without significant investment.

5.2 DISADVANTAGES

- Cost: Implementing RFID technology, along with Arduino Nano microcontrollers, can incur initial setup costs. This includes the purchase of RFID tags, readers, and Arduino Nano components, as well as any additional hardware or software required for integration. For small retailers or those operating on tight budgets, these upfront costs may pose a significant barrier to adoption.
- Complexity of Implementation: Integrating RFID technology with Arduino Nano and existing retail infrastructure requires technical expertise. Retailers may need to invest time and resources into training staff or hiring specialists to manage the implementation process effectively. The complexity of deployment can lead to delays or complications, particularly for retailers with limited technical capabilities.
- Interference and Read Range Limitations: RFID technology may experience interference from nearby metal objects or other electronic devices, affecting read accuracy and range. In a busy retail environment with numerous RFID-enabled devices operating simultaneously, interference issues may arise, leading to incomplete or inaccurate scans. Additionally, the read range of RFID tags and readers is limited, which may require careful positioning of readers within shopping carts to ensure reliable scanning.
- Privacy Concerns: RFID technology raises privacy concerns related to the collection and storage of customer data. As RFID tags track individual products throughout the shopping journey, there is potential for the collection of sensitive information, such as purchase history or shopping preferences. Retailers must implement robust data privacy policies and security measures to safeguard customer information and comply with relevant regulations, such as GDPR or CCPA.
- Dependency on RFID Infrastructure: The effectiveness of RFID-driven shopping carts is contingent on the availability and reliability of RFID infrastructure, including readers, antennas, and backend systems. Any disruptions or malfunctions in the RFID infrastructure can hinder the shopping experience, leading to delays at checkout or inaccuracies in inventory management.
- Limited Compatibility: RFID technology may not be compatible with all types of products or packaging materials. Certain items, such as those made of metal or liquid, may interfere.

VI. CONCLUSION

6.1 CONCLUSION

In the aforementioned paper, the intended system design for automation of the shopping process by merging different technologies like Arduino Uno, RFID, and Android mobile application. That can be divided into two major categories electronic components and Software components. In Electronic Components, Arduino Uno operates as an intermediary

microcontroller, which controls the RFID technology and built, communication between RFID technology and software components like android mobile application through Wi-Fi module.

This feature of wireless information extraction helps the customer to move freely and can easily interact with information of products anywhere in the supermarket. Those technologies are programmed to work together to entertain the customer most efficiently.

By using the proposed technology customers can effectively get the best quality product. This proposed system can easily be implemented in real-life scenarios to support the shopping process by automation of shopping cart.

The RFID-driven smart shopping cart, augmented by Arduino technology, represents a pioneering advancement in the retail landscape, poised to redefine the shopping experience for both consumers and retailers alike. Through the seamless integration of RFID technology and Arduino's versatility, this innovative solution offers a plethora of benefits that transcend traditional shopping paradigms.

At its core, the RFID-driven smart shopping cart simplifies the shopping journey, streamlining processes from item selection to checkout. By automatically detecting items as they are placed in the cart and providing real-time access to product information and personalized recommendations, it empowers consumers to make informed decisions while enhancing convenience and engagement.

Moreover, from a retailer's perspective, the implementation of RFID-driven smart shopping carts yields significant operational efficiencies. The automation of inventory management, coupled with insights derived from RFID data, enables retailers to optimize stock levels, reduce out-of-stock instances, and improve overall supply chain management. Additionally, the streamlined checkout process facilitated by these smart carts enhances operational efficiency, minimizes waiting times, and fosters customer satisfaction and loyalty.

Beyond its immediate benefits, the RFID-driven smart shopping cart underscores the transformative potential of technology in retail. By embracing innovation and harnessing the power of RFID and Arduino, retailers can differentiate themselves in a competitive market landscape, drive revenue growth, and cultivate lasting customer relationships.

As the retail industry continues to evolve, the RFID-driven smart shopping cart stands as a beacon of progress, exemplifying the convergence of technology and consumer-centric design. Its adoption not only signifies a commitment to innovation but also heralds a new era of retail excellence, where efficiency, personalization, and convenience converge to redefine the shopping experience for generations to come. In this journey toward retail reinvention, the RFID-driven smart shopping cart, powered by Arduino, emerges as a symbol of transformation, paving the way for a future where every shopping excursion is a seamless, personalized, and delightful journey.

6.2 FUTURE SCOPE

Enhanced Data Analytics: As RFID technology becomes more sophisticated, the data collected from RFID-driven shopping carts will provide deeper insights into consumer behavior, preferences, and shopping patterns. Advanced analytics algorithms could analyze this data in real-time to offer personalized recommendations, optimize store layouts, and improve inventory management strategies.

Integration with IoT and AI: Integration of RFID-driven shopping carts with Internet of Things (IoT) devices and artificial intelligence (AI) systems could further enhance the shopping experience. For example, AI-powered chatbots or voice assistants could provide real-time product recommendations or answer customer queries as they shop, while IoT sensors could monitor environmental conditions such as temperature and humidity to ensure product quality and safety.

Augmented Reality (AR) Integration: AR technology could be integrated into RFID-driven shopping carts to provide immersive shopping experiences. Customers could use AR-enabled displays or smart glasses to visualize product information, view virtual try-ons for clothing and accessories, or access interactive product demonstrations, enhancing engagement and decision-making.

Mobile Integration: With the widespread adoption of smartphones, future RFID-driven shopping carts could seamlessly integrate with mobile applications. Customers could use their smartphones to access their digital shopping lists, receive personalized promotions, or make contactless payments directly from their mobile devices, enhancing convenience and reducing reliance on physical hardware.

Robotics and Automation: Robotics and automation technologies could be integrated into RFID-driven shopping carts to further streamline the shopping process. Autonomous carts equipped with RFID readers could navigate through store aisles, locate items on customers' shopping lists, and guide customers to their desired products, providing a hands-free shopping experience.

Blockchain Integration: Integration of blockchain technology could enhance the security and traceability of transactions within the retail supply chain. By recording each transaction on a decentralized ledger, blockchain can ensure transparency, reduce fraud, and improve trust between retailers, suppliers, and consumers, creating a more efficient and secure retail ecosystem.

Sustainability Initiatives: Future RFID-driven shopping carts may incorporate sustainability features to support environmental conservation efforts. For example, RFID tags could be made from biodegradable materials, and carts could be designed to encourage eco-friendly shopping practices, such as reducing packaging waste or promoting sustainable product choices.

Global Adoption: As RFID technology continues to mature and costs decrease, we can expect to see increased global adoption of RFID-driven shopping carts across a wide range of retail environments, from large-scale supermarkets to small convenience stores. This widespread adoption will drive innovation and competition, leading to further advancements and improvements in RFID technology.

REFERENCES

- [1]. Mobeen Shahroz, Muhammad Faheem Mushtaq Maqsood Ahmad¹, Saleem Ullah, Arif Mehmood, And Gyu Sang Choi "IoT-Based Smart Shopping Cart Using Radio Frequency Identification", 2020.
- [2]. T.R. Lekhaa, S. Rajeshwari, J. Aiswarya Sequeira, S. Akshayaa "Intelligent Shopping Cart Using Bolt Esp8266 Based on Internet of Things", 2019.
- [3]. Mohit Kumar, Jaspreet Singh, Anju, Varun Sanduja. Smart Trolley with Instant Billing to Ease Queues at shopping malls using ARM7 LPC2148 2018.
- [4]. Vaishali Rane, Krutik Shah, Kaushal Vyas, Sahil Shah, Nishant Upadhyay Smart Trolley Using RFID Jan 2019.
- [5]. M. Shahroz, M. F. Mushtaq, M. Ahmad, S. Ullah, A. Mehmood and G. S. Choi, "IoT-Based Smart shopping cart using radio frequency identification," in IEEE Access, Vol. 8, pp. 68426- 68438, 2020, doi: 10.1109/ACCESS.2020.2986681.
- [6]. S. K. Shankar, S. Balasubramani, S. A. Basha, S. Ariz Ahamed and N. S. Kumar Reddy, "Smart trolley for smart shopping with an advance billing system using IoT," 2021 5th International Conference on Computing Methodologies and Communication (ICCMC), 2021, pp. 390-394, doi: 10.1109/ICCMC51019.2021.9418348.
- [7]. T. R. Lekhaa, S. Rajeshwari, J. A. Sequeira, and S. Akshayaa, "Intelligent shopping cart using bolt esp8266 based on internet of things," 2019 5th Int. Conf. Adv. Comput. Commun. Syst. (ICACCS), 2019, pp. 758–761, doi: 10.1109/ICACCS.2019.8728346.
- [8]. T. R. Lekhaa, S. Rajeshwari, J. A. Sequeira, and S. Akshayaa, "Intelligent shopping cart using bolt esp8266 based on internet of things," 2019 5th Int. Conf. Adv. Comput. Commun. Syst. (ICACCS), 2019, pp. 758–761, doi: 10.1109/ICACCS.2019.8728346.
- [9]. T. K. Meghana, "Smart shopping cart with automated billing system" International Journal of Engineering Research & Technology, Vol. 8, no.11, pp. 88–91, 2020.