

Smart Irrigation System with Moisture-Sensing Technology for Efficient Water Management

Mrs. Poonam Chavan¹, Sakshi Ghogare², Durvas Harkulkar³, Sandesh Kakade⁴, Prachi Kumbhar⁵
Department of Computer Engineering^{1,2,3,4,5}

Pimpri Chinchwad Polytechnic College, Pune, Maharashtra, India

Abstract: *This Project is proposed on precision agriculture system over the Internet of Things (IOT). Through analyzing the current development of precision agriculture in outside world and considering its advantages and shortcomings, we choose an ecology farm as an example to conduct a new precision agriculture management system (PAMS). Designing a private Internet of Things (IOT) enabled platform for the research in precision agriculture and ecological monitoring domains. As water supplies become scarce because of climatically change, there is an urgent need to irrigate more efficiently in order to optimize water use. In this context, farmers' use of a decision-support system is unavoidable. Indeed, the real-time supervision of microclimatic conditions are the only way to know the water needs of a culture. Wireless sensor networks are playing an important role with the advent of the Internet of things in the community of the farmers. It will be judicious to make supervision possible via Sensors.*

Keywords: Agriculture

I. INTRODUCTION

The water harvesting is the backbone of farming industry. As per India is censured lot of water gets wasted due to many regions. So the requirement of water for farm can't get fulfill. Due to the improper maintenance and wrong water harvesting plan the irrigation of water is also the main problem. Day by day the rain percentage is also becoming less and so a very small amount of water is available for the farming. Most of water percentages also get wasted due to lack of proper attention by farmer. So we are present a smart provision to deals with this problem that is nothing but "Automatic Irrigation Control System". Actually we are sensing the Moisture level of Soil by using the sensor and accordingly control the motor. This is the very cost efficient unit as the cost of sensor is very economical. The heart of the system is microcontroller ATmega328. A simple assembly language program can perform all required operation. Since nowadays, in the age of advanced electronics and technology, the life of human being should be simpler and more convenient, there is a need for many automated systems that are capable of replacing or reducing human effort in their daily activities and jobs. Here we introduce one such system, named as automatic plant watering system, which is actually a model of controlling irrigation facilities that uses sensor technology to sense soil moisture with a microcontroller in order to make a smart switching device to help millions of people Can we automatically water our home and garden plants without bothering our neighbors when we decide to go on vacation or somewhere else for a long period? Since irregular watering leads to the mineral loss in the soil and may end up with rotting the plants, can we then somehow know if the soil really needs to be watered and if so, when exactly do we have to water the plants?

We also propose Security is a too much important thing to be concerned in our day-to-day life. Everyone wants to be secured as much as possible. Knowing our home or shop is secure provides us peace of mind. We know now a day's theft has become a major issue. In this project we design an advanced electronic security system by using small water sensors built around the ESP32 controller. water sensor sense the presence of water & Controller reads the signal from sensors and if intruder is detected, it compares the detected signal with predefined signal in the database then it turns on the buzzer as well as making a notification to predefined number

II. LITERATURE SURVEY

1. IOT in Precision Agriculture Applications Using Wireless Moisture Sensor Network.

- Wireless sensor network (WSN) and Wireless Moisture Sensor Network (WMSN) are components of IOT.
- Proper irrigation system could be achieved by using WSN technology.
- Monitoring and control applications have been tremendously improved by using WSN technology.
- It enabled efficient communication with many sensors. WMSN is a WSN with moisture sensors.

2. An Extensible Software Platform for Cloud-based Decision Support and Automation in Precision Agriculture.

- The precision agriculture is a decision support system (DSS) that acquires data from various sources, analyzes them, and recommends actions.
- DSS to control various field devices through unified software defined interfaces.

3. Mobile Integrated Smart Irrigation Management and Monitoring System Using IOT

- The proposed automated irrigation and monitoring system consists of the raspberry pi, water pump, and moisture and temperature sensors Smart phones module is used for communication.
- Architecting an IoT-enabled Platform for Precision Farming.
- In the proposed work, crops or plants are considered along with their water requirement at different stages. The crops or plants are irrigated with respect.
- System has used an android application i.e. Blue term. These applications work totally on Bluetooth. To interface the android application and the master robot we require a Bluetooth module.
- The system features a custom sensor design for power efficiency, cost effectiveness, cheap components, as well as scalability end ease of use.

4. Wireless sensor network for precision agriculture.

The proposed irrigation management system in using intelligent humidity sensor and low power wireless Tran's receiver to collect the data and record SWT for facilitating irrigation management. The monitoring device used in this paper is laptop/computer or PDA. The processed SWT data make it possible to determine soil moisture trends and to predict or modify irrigation schedule for better crop yield.

III. PROPOSED SYSTEM

The objectives of proposed system is to design and produce an automatic watering system thereby saving time & power for the farmer. **Enhancing Agriculture System with water management** is used to automatically provide water to the plants by using moisture sensor which helps in saving money and water. The entire system is controlled using AURDINO ATmega 328microcontroller which is giving the interrupt signal to the motor. Moisture sensor is connected to internal ports of micro controller via connectors, whenever there is a fluctuation in moisture of the soil these sensors senses the change in moisture and gives an interrupt signal to the micro-controller and thus the motor is activated, along with this java application is used to provide user interface on computer screen. A soil moisture sensor is used to monitor the moisture content in the soil and accordingly turn ON/OFF the pump & supply required water to the farmland/plants without any human interference. Java application consist of two modes that's are automatic and manual mode. In automatic mode system is completely depend on sensor. In manual mode system/motor is completely depend on user choice sensor is ignored in this mode. Automatic watering system is designed in such a way which gives required amount of water in a targeted area.

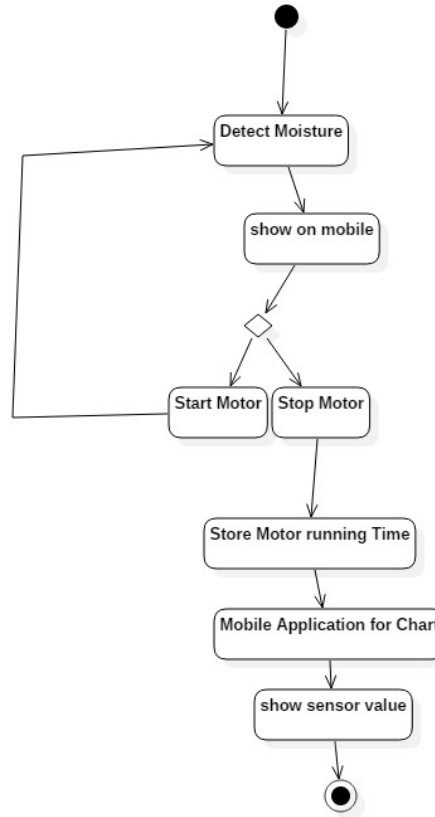

Fig no 1: Project Flow

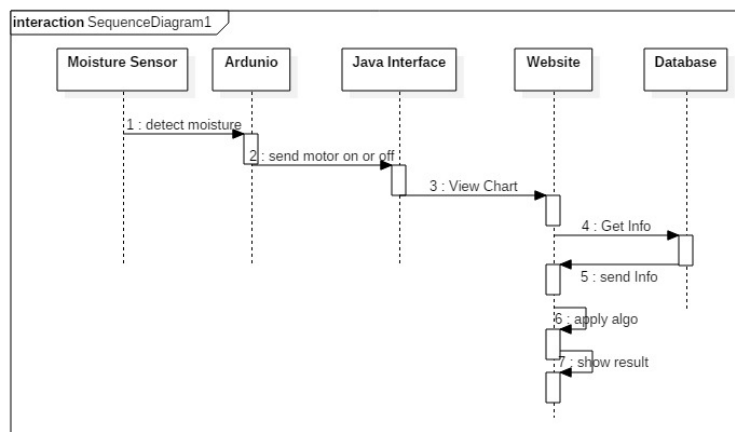

Fig 2. Sequence Diagram

IV. MODULE DESCRIPTION

Smart irrigation system is an effective and green manner of watering fields. It monitors weather, soil conditions, evaporation and plant water use and automatically adjusts watering time table. Hence drawing close clever irrigation machine has turn out to be a top difficulty to give farmer a smart tool which might help them in yielding quality plants three billion populations. India occupies 2nd rank in rice export and as rice crop require large amount of water for

irrigation cause, therefore clever irrigation has tremendous importance in India. In clever irrigation challenge we use unique sorts of sensor to make a farmer updated approximately the field. Sensors used are - soil moisture sensor, water drift sensor and temperature sensor(ds18b20) like a sensor that may calculate the amount of water used in the subject, a soil moisture sensor that can calculate the moisture profile of the field if you want to prevent crops from water logging issues and a temperature sensing sensor so that you can still test the temperature of the crops because plants are temperature touchy too and if the smart system conscious the farmer earlier than then farmer can use sprinklers a good way to cool down temperature of the crops it might save each crop and farmer. Our method is to make this device on hand from even a ways distance in order that farmer has the information and control on the field 24x7 for the duration of a year. The entire setup is controlled by means of an arduino.

Features:

- Introduce an emerging technology like IoT into conventional methods of agriculture.
- To keep water and decrease human intervention within the agriculture discipline.
- Enhance digital literacy into farmers.
- Continuously monitoring the status of moisture degree in soil and provide sign for taking important motion

V. CONCLUSION

The Proposed system will help to automate the Motor in any electric system manually as well as automatically by sensing a moisture of the Soil. Our system will also help limit the water usage and saves money. Our system will also reduce the manual work by automating the process.

REFERENCES

- [1] Kshitijshinghal, Dr. Artinoor, Dr. Neelamsrivastava, Dr. Raghuvirsingh, wireless sensor networks in agriculture: for potato farming.
- [2] Prakash gaud patil, vidya h2, shreedevipatil, umakantkulkarni, wireless sensor network for precision agriculture, 2011.
- [3] Jianfa Xia, Zhenzhou Tang, *Xiaoqiu Shi, Lei Fan, Huaizhong Li, An environment monitoring system for precise agriculture based on wireless sensor networks, 2011.
- [4] A Survey on Zigbee Based Wireless Sensor Networks in Agriculture T.Kalaivani, A. Allirani, P. Priya, 2011 IEEE.
- [5] Design and Implementation of a smart irrigation system for improved water-energy efficiency, kizitomasaba, AminiNtakirutimana, tahaselimustan.
- [6] Mobile Integrated Smart Irrigation Management and Monitoring System Using IOT, Vaishali S, Suraj S, Vignesh G, Dhivya S and Udhayakumar S., International Conference on Communication and Signal Processing, April 6-8, 2017, India.