

# Sand Casting Parameter Optimization by Numerical Method

**Mr. Sharadchandra V. Kantute and Mr. Prashant R. Wankhede**

Lecturer, Bharati Vidyapeeth Institute of Technology, Navi Mumbai, Maharashtra, India

**Abstract:** *The current research work is based on the sand casting simulation of pressure plate in virtual environment of Pro Cast. Design of gating and filling system is one of the complicated process it take more experience and expertise to avoid the crack and impurities in casting product. Improper design of gating and filling system is causes of wrong location of runner and riser and it subjected to crack, impurities, shrinkage and porosity. The current research work is based on setting of optimum configuration of gating system including height of sprue in three different combination of casting mould. Here we selected three different height 110 mm, 130 mm and 140 mm of pouring basin with same runner design to find out most suitable parameter for favourable condition of casting. The key parameter of simulation is selected as filling and solidification time with hot spot region and based on the parameter the optimum parameter is selected for sand casting of pressure plate*

**Keywords:** FEA Finite element analysis, FVM- Finite Volume Method, 2 D two dimensional, FDM- Finite Difference Method

## I. INTRODUCTION

It is a process by which molten metal is poured into the mould cavity whose shape is same as that of the shape of the material to be produced, allow it to solidify and after solidification; the product will be taken out by breaking the mould. Casting is one of the most ancient techniques of manufacturing the metal. In manufacturing processes, casting is one of the most economical production processes, which involve considerable metallurgical and mechanical aspects. Various procedures have been created in the industry where each procedure is particular to the metal utilized and the outcomes wanted. Inside each procedure there are a few factors that effect the plan of conclusive item. Today, castings are utilized in various marketplaces in an assortment of uses that range from assembling to home stylistic theme. Because of the high competitions in market and a need to produce sound casting, a simulation is essential to obtain optimum dimensions. In this project, the use of simulation is done for calculating the optimum dimension of riser for a column with "constraint optimization in pro cast software. Constraint optimization in pro cast software is complete general purpose simulation software of casting. Hence faster and adequate results for calculating height and diameter of riser are made and it also reduces the no. of shop floor trials for calculating the optimum dimension of riser than the experimental methods.

Some of the major casting components are -

- Automobile Casting Equipment
- Pumps and Valves Component
- Scientific Casting Equipment etc.

## II. PROBLEM IDENTIFICATION

India is second largest manufacturer of casting components but still most of the Indian industries or manufacturer preferred the traditional and trial and error method to design the gating and feeding system for foundry shop. Designing of gating and feeding system is purely based on the knowledge and experience of fluid flow and thermal science. As the gating system is entirely theoretical approaches the final result may not satisfy the real time situation. so we added the simulation program in form of virtual model. With the aid of computer the result of simulation of gating and feeding system is turned in such a way that the practical approaches of proposed application or system is very near to the virtual

simulation. Here we are using the Pro cast simulation software, which is one of the popular finite element analysis software for casting simulation and optimization.

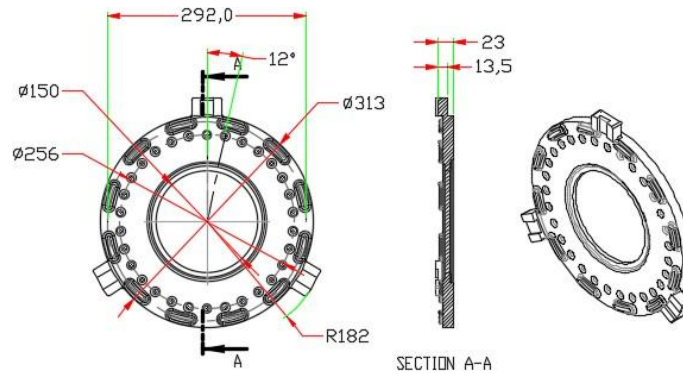

Fig. 1 Schematic representation of pressure plate

### III. METHODOLOGY

The gating filling system must fulfill the whole cavity of mould before it lose the fluidity of molten metal. The runner should not consist of any back flow of metal due to its graphitization expansion of cast iron. The gating system must allow molten metal into the mould with less turbulence and minimize turbulence in the runner regions. Cast iron flow with high melting temperatures and therefore its velocity must be controlled carefully. The solid works provide the support of assembled all parts of mould in single workbench so here the gating system along with pouring basin and runner is assembled and for the completethree dimensional model of pressure plate.

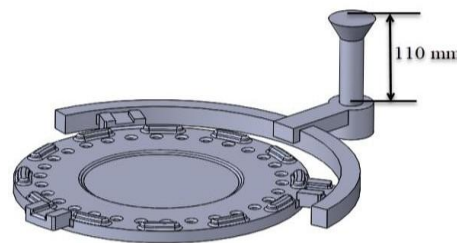

Fig 2. pressure plate 3D Model

The gravity of part should be downward to maintain the flow of pouring material with desire velocity and proper filling of cavity. in our case the z negative show the direction of gravity.



Fig. 3 Meshing of pressure plate

The inner cavity of mould or the pressure plate geometry is define the material medium carbon and themould of plate is assign as green sand mould it shown in figure below.

We need to calculate the flow time of systemAs our volume flow rate is fixed,

Volume of the entire system = 9.745 Kg

Pre-determined volume flow rate =  $1.7592 \times 10^{-4}$  m<sup>3</sup>/s Filling Time = 6.75 s-7 s

Simulation of casting Temperature distribution

As discussed in previous paragraph the simulation iteration take few hours to simulate the molten metal according to the geometry of the mold. The result obtained by the cast simulation is shown below in graphical form

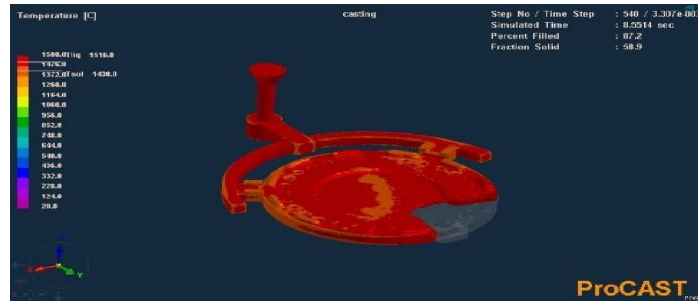

Fig 4 distribution of molten metal into the cavity

### Solidification of casting

The total time taken to fill the interior cavity is 8.97 second and the solidification time 1835 sec to cool at 600<sup>0</sup>c and total frame time required to simulate is 2445 frame. The corresponding solidification is given in the picture below.

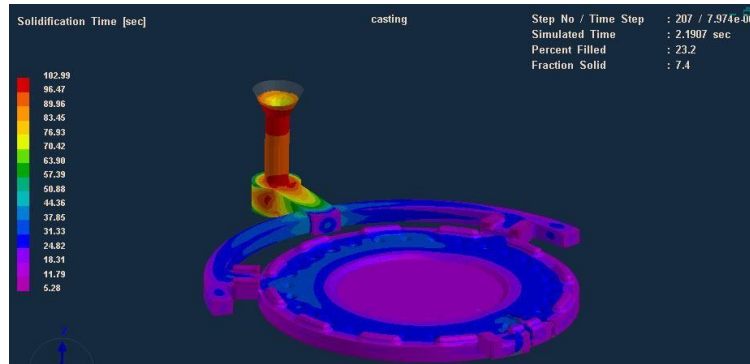

Fig. 5 solidification of molten metal for case I

### Hot Spot Zone of casting

The XZ plate is used to determine the hot zone by color gradient it shown in figure below. It clearly visible that the outer circle of plate consist of some hot zone, it will cool down at last. Problem areas will be regions, which solidify at the last. This basic yet successful plot may state whether a spot may have a few issues. Well this is inadequate to anticipate the seriousness of the deformity or the imperfection itself. In cast iron castings problem areas do not aggravate much until the point that they are presented to machining. These problem areas might be of carbide and may likewise have shrinkage hole. The material thickness plot affirmed that we have no shrinkage cavity of that sort

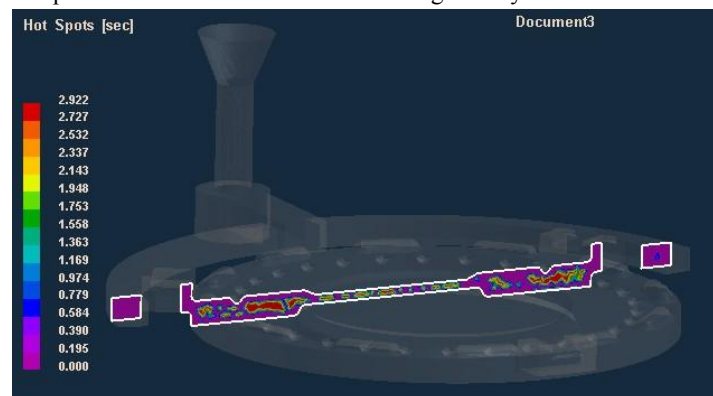

Fig. 6 Hot Spot Zone of casting

#### IV. RESULT AND DISCUSSION AND CONCLUSION

The casting simulation obtained by analysis of pressure plate is shown in figure above so it is clear that the temperature distribution and filling of cavity by molten metal and solidification of cast material which cool down from 1500<sup>0</sup>c to 600<sup>0</sup>c . The parameter of runner and sprue is calculated and shrinkage of metal is considered as 3% of total volume of pressure plate. The total time taken to fill the interior cavity is 8.97 second and the solidification time 1835 sec to cool at 600<sup>0</sup>c and total frame time required to simulate is 2445 frame. The region of hot spot is obtained in the outer circumference of the pressure plate.

#### Comparison of Simulation Result of All Cases.

The simulation result of all cases has compared based on filling time of molten metal and solidification of pouring metal and also based on forming hot spot. After the critical analysis of hot spot zone of case I , II and III with reference to figure No. 4.20, 4.23 and 4.26, it is observed that after solidification the case I subjected to hot spot of in the outer diameter of pressure and in case II and III it also found but its observed near to the runner instead of pressure plate.

Table 1 Simulation Result of sand casting

S No.	Pouring Time	Solidification Time	hot spot
case 1	8.97	1835	Dense
case 2	6.89	1344	Less
case 3	10.6	1746	Less

Casting simulation by FEA is used to predict the location of shrinkage and porosity and also to see the flow of molten metal and solidification time of cast. it help the founder men to optimized the gating and feeding system for desired quality and optimum surface finishing without crack. The simulation of sand casting reduces the directional solidification defect and provide the defect free casting.

Finally, we concluded as:

- We have good distribution of material flow.
- No shrinkage are predicted during the cast simulation.
- We have sensible directional solidification of hot metal.

#### REFERENCES

- [1] G. Mi et al., "Numerical Simulation and Optimization of the Casting Process of A Casting-Steel Wheel" Engineering Review, Vol. 33, Issue 2, 93-99, 2013.
- [2] C. M. Choudhari, et al, "Casting Design and Simulation of Cover Plate using AutoCAST-X Software for Defect Minimization with Experimental Validation", Elsevier 190 Procedia Materials Science 6 ( 2014 ) 786 – 797.
- [3] M. N. Jadhav, "Numerical Optimization of Grey C.I. Casting using Simulation." IOSR Journal of Mechanical and Civil Engineering (IOSR-JMCE), e-ISSN: 2278-1684, p-ISSN: 2320-334X PP. 47-51.
- [4] Gondkar et. al. "Optimization of Casting Process Parameters through Simulation." International Journal of Application or Innovation in Engineering & Management (IJAEM) ISSN 2319 – 4847, Volume 3, Issue 6, June 2014.
- [5] Hassen Iqbal et al "Mold design optimization for sand casting of complex geometries using advance simulation tools" Taylor & francis Group, LLC.
- [6] He Binfeng "Simulation and Optimization of Steel Casting by Sand Casting". Advanced Materials Research Vols. 706- 708 (2013) pp 258-261.