

# Distance Locator for an Underground Cable Fault

Rohit Khandu Jarande<sup>1</sup>, Juhi Liladhar Dawale<sup>2</sup>, Jatin Shailesh Chaudhari<sup>3</sup>, Sarthak Anna Shende<sup>4</sup>,  
Pooja Santosh Khandekar<sup>5</sup>, Keya Shailendra Gawai<sup>6</sup>

Third Year Engineering, Department of Electrical Engineering

Jawaharlal Darda Institute of Engineering and Technology Yavatmal, India<sup>123456</sup>

Jaranderohit41@gmail.com<sup>1</sup>, Juhi.dawale.@gmail.com<sup>2</sup>, chaudharijatin79@gmail.com<sup>3</sup>,  
Sarthakshende123@gmail.com<sup>4</sup>, poojakhandekar6266@gmil.com<sup>5</sup>, keyagawai9@gmail.com<sup>6</sup>

**Abstract:** In this paper, a way for sleuthing underground cable fault distance locator is done by using microcontroller. The target of this project is to work out the gap of underground cable fault through base station in kilometers. It uses the straight forward conception of ohm's law, voltage drop can vary counting on the length of fault in cable, since the current varies. A group of resistors are used to represent the length of cable in kilometers and a dc voltage is fed at one end and the fault is detected the change in voltage using analog to voltage converter. The fault occurring at what distance is shown on LCD which is interfaced with the microcontroller that is used to make the necessary calculations.

**Keywords:** Underground cable, fault location, fault detection, location method, microcontroller

## I. INTRODUCTION

For most of the worldwide operated low voltage and medium voltage distribution lines underground cables have been used from many decades. To reduce the sensitivity of distribution networks to environmental influences underground high voltage cables are used more and more. Underground cables have been widely used in power distribution networks due to the advantages of underground connection, involving more security than overhead lines in bad weather, less liable to damage by storms or lightning. It is less expensive for shorter distance, eco- friendly and low maintenance



Figure 1: Underground cable fault

But if any fault occur in cable, then it is difficult to locate fault. So this project is used to detect the location of fault in digital way. The requirement of locating the faulty point in an underground cable in order is to facilitate quicker repair, improve the system reliability and reduced outage period. The underground cable system is very useful for distribution mainly in metropolitan cities, airport and defense services.

## II. FAULT IN CABLE

Fault in a cable is defined as a physical condition that causes a device, a component, or an element to fail to perform in a required manner[3]. It will occur because of any defect, weakness or nonhomogeneity or by breaking of conductor

and failure of insulation. Power cable fault location techniques are used in power system for accurate pin pointing of the fault positions. The benefits of accurate location of fault are:

- Fast repair to revive back the power system.
- Improve the system availability and performance.
- Reduce operating expense and save the time needed by the crew searching in bad weather, noisy area and tough terrains.

### 2.1 Types of Fault in a Cable

A fault may be a bolted connection or may have some electric resistance within the fault association. The fault can be basically mainly in two categories:

- Open circuit fault: Open circuit fault happens, when there is a break in the conducting path of a cable. These kind of faults are better comparatively short circuit faults because when these fault occur current flows through cable becomes zero. The open-circuit fault can be detect by megger by measuring resistance between each conductors and earth.
- Short circuit fault: An abnormal connection of comparatively low electric resistance, whether created accidentally or intentionally, between two points of various potential. When two conductors of multi core cable come in electrical contact with one another because of insulation failure, it is thus referred to as short-circuit fault.

### 2.2 Block Diagram

In this project simple Ohm's law is used to locate the short circuit fault, where a DC voltage is applied at the feeder end through a series resistor, depending upon the length of fault of the cable current varies. The voltage drop across the series resistor changes accordingly and this voltage drop is used in detection of fault location in the underground cables. The below figure is a block diagram of underground cable fault distance surveyor. In this project power supply consists of a step down transformer (230/12V), which step down the voltage to 12V AC and it is converted into DC by using a Bridge rectifier. It is assembled with a group of resistors representing cable lengths in kilometers.

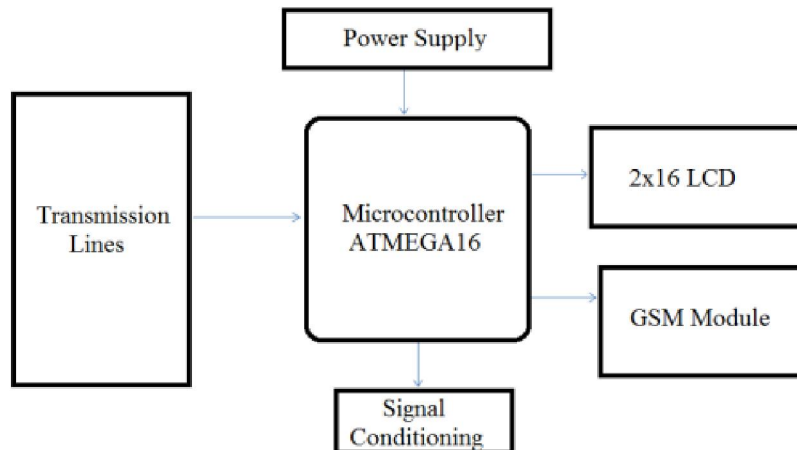

Figure 2: Block diagram of underground cable fault distance surveyor.

The voltage drop across the feeder resistor is given to an ADC which supplies a digital information which the programmed microcontroller would show an equivalent on LCD in kilometers.

### 2.3 Operating Procedure

The program while executed continuously scans by operating the 3 relays in sequence of one sec interval. If any of the 12 switches found to be faulted then the voltage drop at the ADC (which is inbuilt in microcontroller) pin varies depending on the current flow which is reciprocally proportional to the resistive value of the length of the cable in kms. The circuit diagram of underground cable fault distance surveyor is shown in fig 4. This variable voltage is fed to the

ADC to develop an 8 bit information to the microcontroller port A and therefore the distance is shown of the faulted switch on the LCD.

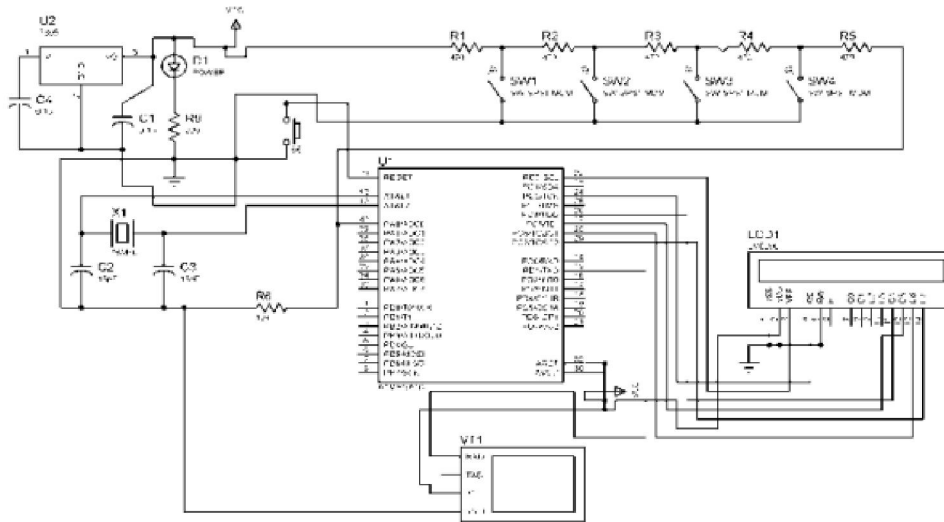

Figure 3: Circuit diagram

### III. OBSERVATIONS

In this simulation, the four sets of resistors connected in series representing cables i.e. R1, R2, R3, R4; R5, R6, R7, R8; R9, R10, R11, R12 and R13, R15, R16, R17 and twelve switches representing faults are simulated using PSIM software

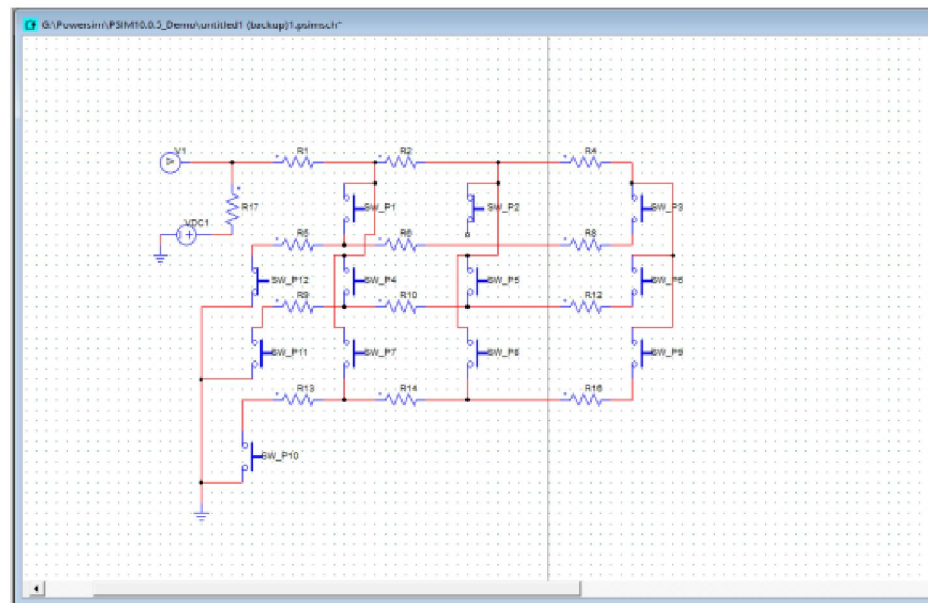

Figure 4: Simulation circuit of switch and resistors using PSIM software

### IV. RESULT

In the below figure the simulated output is shown when the third switch is closed. The voltage drop across a series resistor is 4.25V when switch three is closed.

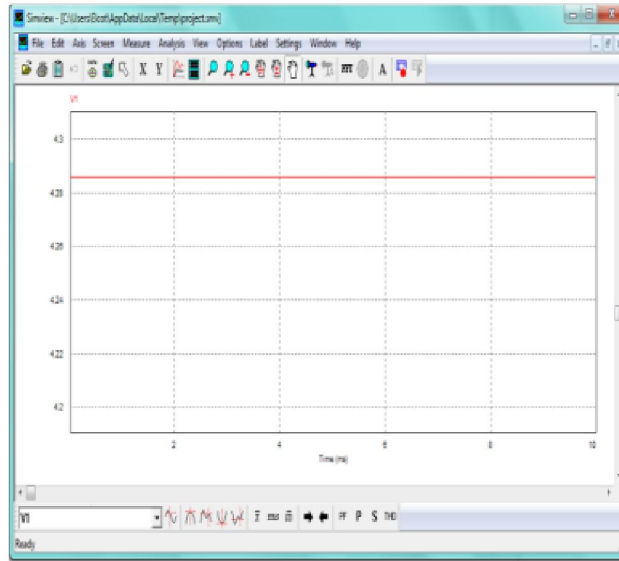

Figure 5: Simulated output when Switch 2 is closed

The voltage drop across series resistor when different switches are, closed is shown in below table.

Table 1: Output voltage across series resistor

Sr. No.	Closed switch	Voltage across series resistor (V)	Distance at which fault occurred (Km)
1.	Switch 1	3.35 V	1 Km
2.	Switch 5	5 V	2 Km
3.	Switch 2	4.25 V	2 Km
4.	Switch 3	4.5 V	3 Km

## V. SIMULATION SOFTWARE

PSIM is one of the fastest simulators for power electronics simulation. It achieves fast simulation while retaining excellent simulation accuracy. This makes it particularly efficient in simulating converter systems of any size, and performing multiple-cycle simulation. PSIM is the engine of the simulation environment. PSIM uses a strong algorithm dedicated to electrical circuits (piecewise method, generic models and a fixed time-step). The fast simulation allows repetitive simulation runs and significantly shortens the design cycle. PSIM can simulate control circuit in various forms: in analog circuit, s-domain transfer function block diagram, z-domain transfer function block diagram, custom C code, or in Matlab. PSIM's control library provides a comprehensive list of components and function blocks, and makes it possible to build virtually any control scheme quickly and conveniently.

## VI. CONCLUSION

In this paper we detect the location of open circuit and short circuit fault in the underground cable from the base station in kms with the help of Atmega16. For this we use concept of ohms law so that fault location can be detected.

## REFERENCES

- [1] B.Clegg, "Underground Cable Fault Location. McGraw- Hill, 1993.
- [2] DhivyaDharani.A, Sowmya.T, "Development of a prototype of Underground Cable Fault Detector", IJEECS, Vol-2, 2014.
- [3] Dhekale P.M., Prof. Suryawanshi R.R., "Underground Cable Fault Distance Locator", IJIERT, vol-2, April2015.
- [4] M.-S. Choi, D.-S. Lee, and X. Yang, "A line to ground fault location algorithm for underground cable system," KIEE Trans. Power Eng., pp. 267–273, Jun. 2005.

- [5] J. Densley, "Ageing mechanisms and diagnostics for power cables—an overview," IEEE Electronic Insulation Mag., vol. 17, no. 1, pp. 14–22, Jan./Feb. 2001.
- [6] K.K. Kuan, Prof. K. Warwick, "Real-time expert system for fault location on high voltage underground distribution cables", IEEE PROCEEDINGS-C, Vol. 139, No. 3, MAY 1992.
- [7] A S Pabla, 2004, "Electric Power Distribution", McGraw Hill 2004.
- [8] J. P Steiner, W.L. Weeks, and H.W. Ng. 1992. "An Automated Fault Locating System," IEEE Trans. on Power Delivery, Vol. 7, No 2, pp. 967-978, April 1992.
- [9] S. Navaneethan, J. J. Soraghan, W.H. Siew, R. Muirhead, and J. Livie, 1998, "An Automatic Fault Detection and Location Technique in Low Voltage Distribution Networks," Proc. of Energy Management and Power Delivery '98, March 1998, PP. 732-736.
- [10] C.M. Wiggins, D.E. Thomas, T.M. Salas, F.S. Nickel, and H.-W. Ng, "A novel concept for underground cable system," IEEE Transaction Power Delivery, Vol. 9, No. 1, pp. 591-597, Jan 1994.
- [11] M.-S. Choi, D.-S. Lee, and X. Yang, and X. yang, "A line to ground fault location algorithm for underground cable system," IEEE International Transactions on Power Engineering, Vol. 54, pp. 267-273, Jun. 2005.
- [12] EC Bascom and D.W. Von Dollen, "Computerized underground cable fault location expertise," in IEEE Power Engineering Society Transmission and Distribution Conference, pp. 376-382, 10-15 April 1994.
- [13] S. Potivejkul, P. Kerdonfag, S. Jannian, and V. Kinnares, "Design of low voltage cable fault detector," in Proc. IEEE Power Engineer. Society. Winter Meeting, Jan. 2000, Vol. 1, pp. 724-729.
- [14] Md. Fakhrul Islam, Amanullah M T Oo, Salahuddin. A. Azadl, "Locating Underground Cable Faults: A Review and Guideline for New Development", 2013 IEEE