

# OSI Model

**Nitin Madhu Kamble and Renuka Uday Kotwal**

Institute of Distance and Open Learning, Mumbai, Maharashtra, India

**Abstract:**

- The International Organization for Standardization, better known by its abbreviation OSI Model, is an organization that establishes the fundamental communication protocols for computer networks.
- We refer to the OSI Model in multiple places since the problems fall into one of its seven models.
- The highest level of abstraction in the OSI architecture is the OSI Reference Model.
- The primary building sections used to create the network model are initially described in the release..

**Keywords:** OSI Model

## I. INTRODUCTION

Network construction was inconsistent in the beginning. Each vendor provided a unique solution. It was problematic that one vendor's solution was incompatible with another vendor's. In response, the OSI model concept was developed. Our hardware suppliers would design hardware for the network layer under our layered approach to networks, while others may provide software for the application layer. We are capable of building networks that work well with each other by using an open paradigm that everyone can agree on.

The OSI model, which was introduced in 1984, is the product of the International Organization for Standardization's (ISO) study of several network models to address this issue. Nowadays, the majority of vendors construct networks based on the OSI model, and hardware from many vendors is compatible. Excellent!

The OSI model is one of the BEST ways to teach people about networks, as well as a paradigm for making networks interoperable. Remember this since the OSI model will be mentioned frequently while you are learning networking.

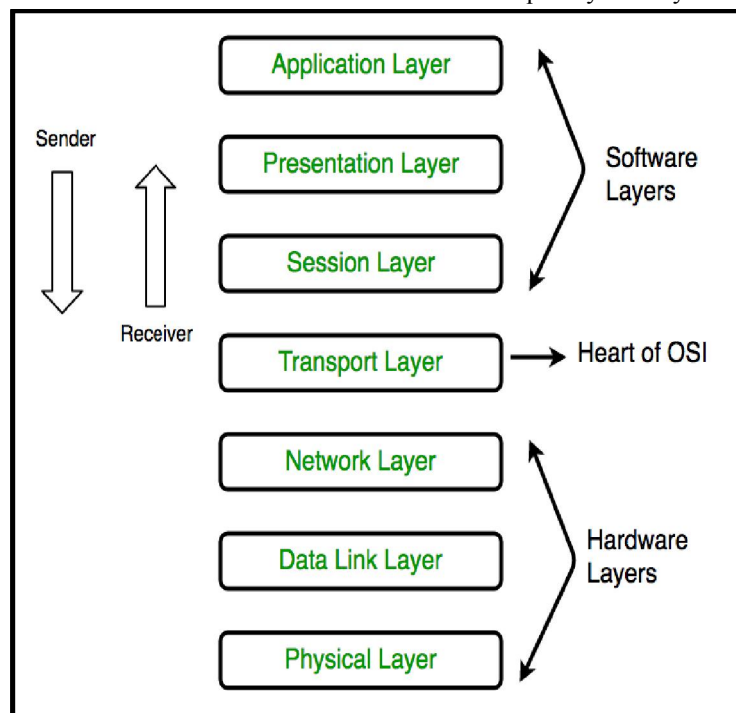

**OSI MODEL**

## II. HISTORY OF OSI MODEL

The OSI model was created in the late 1970s to facilitate the growth of several computer networking techniques that were competing for use in the world's major national networking initiatives (see OSI protocols and Protocol Wars).

The paradigm was developed by the Open Systems Interconnection group of the International Organization for Standardization (ISO) in the 1980s and is currently in use.

The less prescriptive Internet Protocol Suite, primarily sponsored by the Internet Engineering Task Force (IETF), reflects how the paradigm, which attempted to provide a comprehensive definition of networking, failed to gain reliance during the Internet design.

Hubert Zimmermann, a French software developer, developed the OSI model for the first time in its undeveloped form in Washington, D.C., in February 1978. In 1980, the ISO published the OSI model's modified but unfinished draft standard.

OSI was an industry project that aimed to encourage industry partners to agree on common network standards that would allow multi-vendor interoperability. Huge networks frequently supported various network protocol suites, with many devices unable to communicate with one another due to a lack of common protocols. For a while in the late 1980s and early 1990s, engineers, corporations, and nations were divided over whether to use the OSI model or the Internet protocol.

The OSI standards documents are available from the ITU-T as recommendations in the X.200 series. Some protocol specifications were also included in the ITU-T X series. ISO provided equivalent ISO and ISO/IEC standards for the OSI model, although only part of it was free.

## III. INTRODUCTION TO 7 LAYERS OF OSI MODEL

### 3.1 Layer 1- Physical Layer

The physical layer is the lowest layer of the OSI reference model. It is in charge of the physical connection between the devices. The physical layer stores data in the form of bits. It is in responsible for transmitting individual bits from one node to the next. When this layer receives data, it converts the received signal into 0s and 1s and sends them to the Data Link layer, which reassembles the frame.

Physical Layer devices include hubs, repeaters, modems, and cables.

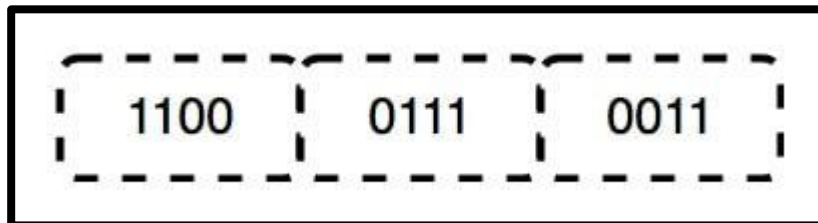

Bits of data at the physical layer

- **Bit synchronization:** The physical layer synchronizes the bits by providing a clock. This clock controls both the sender and the receiver, allowing for bit-level synchronization. The Physical layer also defines the transmission rate or the number of bits transferred per second.
- **Physical topologies:** The physical layer determines how different devices/nodes in a network are grouped, such as a bus, star, or mesh topology.
- **Transmission mode:** The physical layer dictates how data travels between two linked devices. Simplex, half-duplex, and full-duplex transmission modes are available.

### 3.2 Layer 2- Data Link Layer (DLL):

The data connection layer is responsible for delivering messages from node to node. The primary goal of this layer is to ensure error-free data flow from one node to another over the physical layer. When a packet comes into a network, it is the DLL's job to send it to the Host using its MAC address.

The Data Link Layer is split into two sublayers:

- Logical Link Control (LLC)
- Media Access Control (MAC)

The network layer packet is further broken into frames based on the frame size of the NIC (Network Interface Card). DLL also includes the MAC addresses of the Sender and Receiver in the header.

The MAC address of the receiver is retrieved by sending an ARP (Address Resolution Protocol) request across the wire asking, "Who has that IP address?" and the target host's MAC address will be returned.

- **Framing:** The data connection layer is responsible for framing. It offers a method for a sender to deliver a group of bits that are significant to the recipient. By including unique bit patterns at the start and end of the frame, this may be achieved.
- **Physical addressing:** The Data link layer inserts the sender's and/or receiver's MAC addresses to each frame's header after constructing it.
- **Controlling errors:** The data link layer offers an error control system that identifies and retransmits corrupted or missing frames. Flow control controls the amount of data that may be transferred before getting an acknowledgment since the data rate must be consistent on both sides in order to prevent data corruption.
- **Access control:** When several devices share a single communication channel, the data link layer's MAC sub-layer assists in identifying which device is in charge of the channel at any given moment.

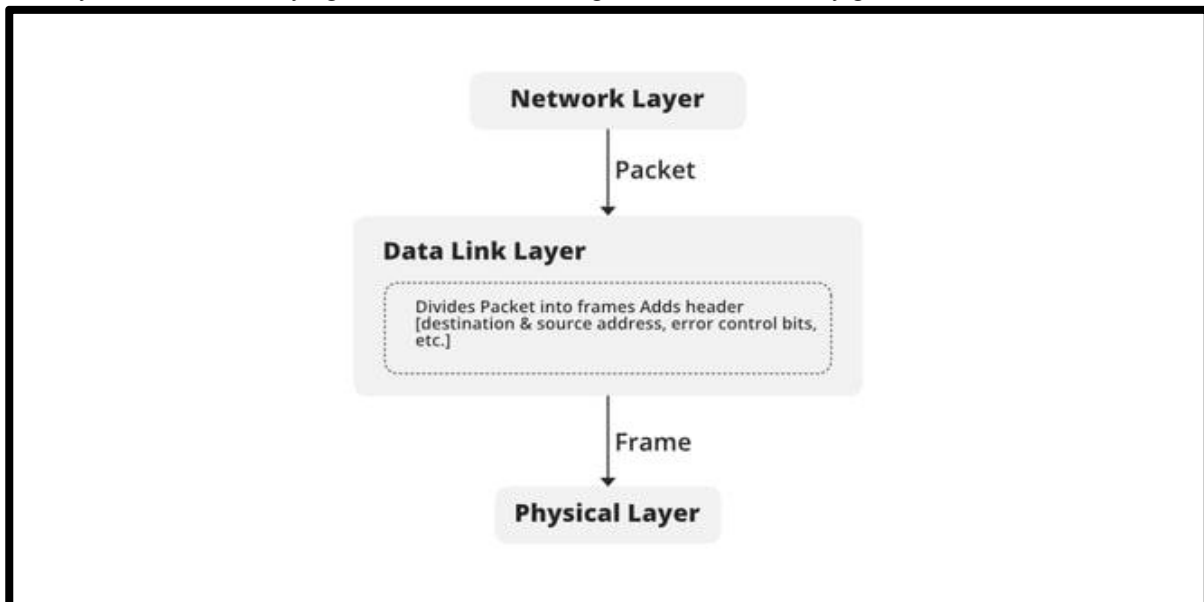

Data Link Layer

### 3.3 Layer 3- Network Layer:

The network layer is responsible for data transfer from one host to another located in distinct networks. It also handles packet routing, which is the choosing of the quickest path to send the packet from among the available routes. The network layer places the IP addresses of the sender and receiver in the header.

- **Routing:** The network layer protocols determine which path from source to destination is best. This network layer function is known as routing.
- **Logical Addressing:** The network layer specifies an addressing method to uniquely identify each device on the Internetwork. The network layer inserts the IP addresses of the sender and receiver into the header. Such an address uniquely and globally recognizes each device.

The term "Packet" refers to a segment in the network layer.

Networking hardware like routers and switches are used to implement the network layer.

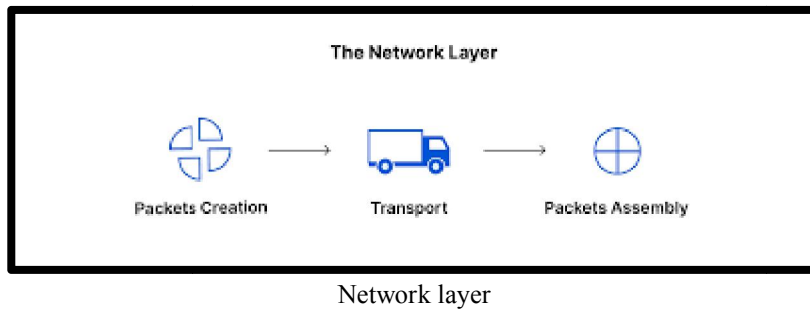

### 3.4 Layer 4- Transport Layer

The transport layer provides the application layer and receives services from the network layer. Segments are the units of data in the transport layer. It is in charge of delivering the entire message from beginning to end. The transport layer also acknowledges successful data transfer and re-transmits data if an error is detected.

To guarantee correct data transfer, the transport layer receives prepared data from the top levels, conducts segmentation, and provides Flow and error control. It also includes Source and Destination port numbers in its header and sends segmented data to the Network Layer.

- **Segmentation and Reassembly:** This layer receives the message from the (session) layer and divides it into smaller components. Each segment created has a header attached to it. The message is reassembled at the destination station by the transport layer.
- **Service Point Addressing:** The transport layer header includes a form of address called service point address or port address to deliver the message to the relevant process. The transport layer ensures that the message is delivered to the relevant process by supplying this address.

#### Services Provided by Transport Layer

- Connection-Oriented Service
- Connectionless Service

#### Connection-Oriented Service:

It is a three-phase process that includes  
 Connection Establishment  
 Data Transfer  
 Termination/disconnection

In this type of transmission, the receiving device sends an acknowledgment, back to the source after a packet or group of packets is received. This type of transmission is reliable and secure.

#### Connectionless service:

It is a one-step procedure that incorporates data transfer. The receiver does not confirm receipt of a packet in this sort of communication. This method enables substantially quicker communication between devices. Connection-oriented service outperforms connectionless service.

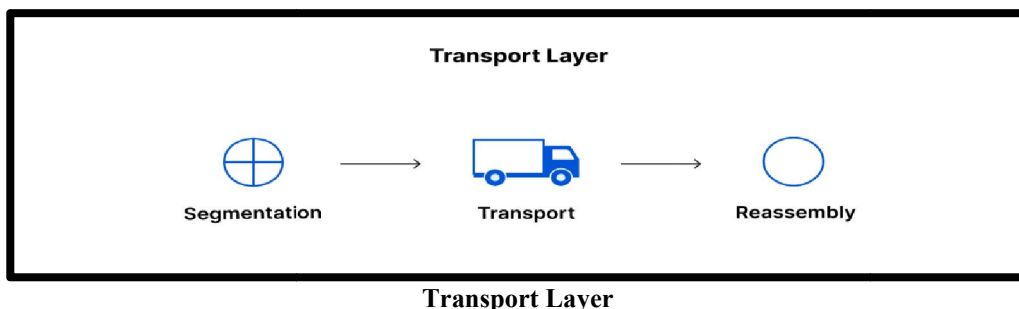

### 3.5 Layer 5- Session Layer:

OSI Model is is of Computer Networking. Session Layer is layer 5 in it.

Its provides the mechanism for opening, closing and managing a session of application processes. In Communication sessions there is requests and responses in applications. In application enviornments session layer is supports application layer for **remote procedure calls (RPCs)**.

X.225 or ISO 8327 is another names of session Layer. This protocol is help us , when In case connection loss is happened. And then for recover connection session layer is help you. The Session Layer Protocol may close it and re-open it when, if connection is not used for long period.

Session Layer provides for either full duplex or half-duplex. Session Layer provides

Synchronization points in stream of exchanged messages.

Implementation of session layer is **Zone Information Protocol(ZIP), Session Control Protocol(SCP)**.

**The name of data unit in the session layer is SPDU (Session Protocol Data Unit) or Sessions.**

Virtual connection between application entities.

Synchronization of data flow

Creation of dialogue units.

Connection parameter negotiations.

Partitioning of services into functional groups.

Acknowledgements of data received during a session.

Retransmission of data if it is not received by a device.

## Session Layer

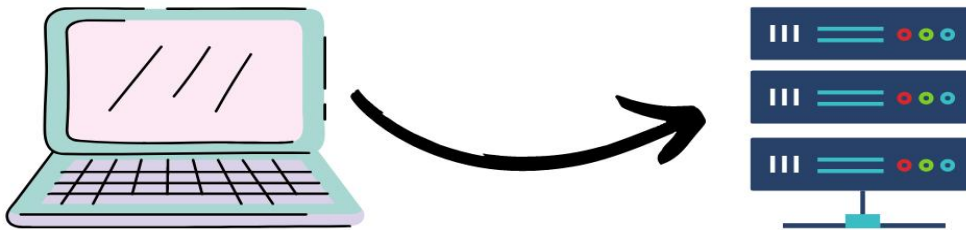

Manages connection between client and server

### 3.6 Layer 6- Presentation Layer:

The presented application layer by the presentation layer formats. The Presentation Layer can be viewed as the translator for the network. The presentation layer may translate data from a format used by the application layer into a common format at the sending station, and the common format to a format known to the application layer at the receiving station.

The Presentation layer Provides:

Character Code translation: For e.g., ASCII

Data Conversion: bit order-CR/LF, integer-floating point

Data Compression: reduces the number of bits that need to be transmitted on the network.

Data encryption: encrypt data for security purposes.

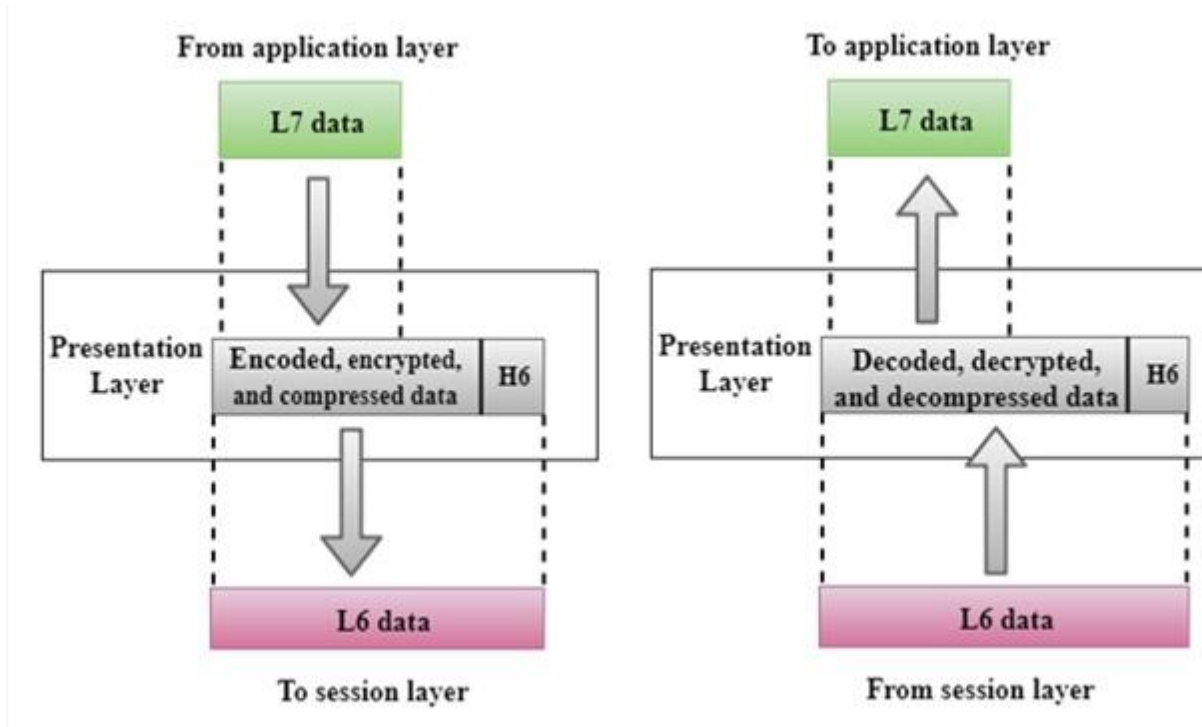

**3.7 Layer 7- Application Layer:**

This Level is user interacts with. Application Layer where data turns into websites, Chat Programs and so on. Many protocols runs at this layer, such as DNS, FTP, HTTP, HTTPS, NFS, POP3, SMTP and SSH.

The abstraction layer that specifies the shared communications protocols methods used by hosts in a communications network is called Application Layer.

An Application Layer abstraction is specified in both the Internet Protocol Suite (TCP/IP) and the OSI model.

# Application Layer

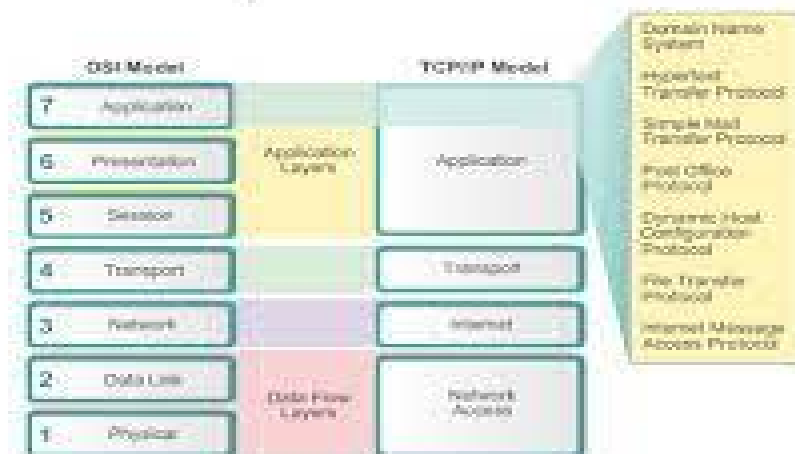

**IV. BENEFITS OF THE OSI MODEL**

**Compatibility:**

The OSI Model can fit to any software or hardware from different users. In other parts of the world.

**Easy Troubleshooting:**

Each Layer in OSI Model is independent of each other and then they will detect and solve all errors prevailing in it.

**Easy Understanding Nature:**

This is Interactive Model and Guides us to know what a Model is.

**Security:**

This Model is for Encryption and Decryption which has a major contribution for security purpose.

**V. CONCLUSION**

OSI Model is an architecture which totally based on seven layers. It only gives us an idea how packets transfer over the network during any communication.