

# Talent Management Impact on Job Satisfaction and Employee Performance of NBFC Employees

**Gibin Jacob**

Assistant Professor

St Paul's College, Kalamassery, India

**Abstract:** Talent management is the core functional unit of an organization, and In order to enhance the productive performance of employees, talent management uses human resource planning to achieve this goal. To make them a part of talent management and strategic workforce planning, efforts have been made to retain, develop, attract, and reward employees. Talent management can lead to higher level performance and satisfaction of employees' instead of being a process of hiring; reinforcing and evaluating the aptitude. Keeping in mind the necessity of talent management, this paper analyzes probable scenarios of talent management practices in public sector banks and how these practices, in turn, improve bank employees' performance. Furthermore, it examined how talent management practices could influence the employees' satisfaction in Indian public sector banks. This research paper puts forward a set of valid hypotheses that talent management practices affect employee performance and satisfaction. This paper seeks to confirm these hypotheses on a survey based on data collected from the employees of the public sector banks in the Indian state of Rajasthan. The study will tender to the talent management literature by pondering how talent management practices affect the organizational outcomes, such as employee satisfaction and performance.

**Keywords:** Talent Management; Employee Satisfaction; Employee Performance

## I. INTRODUCTION

Talent management is considered the backbone of HRM, as it helps investment in those who may offer future potency to meet the decisive objectives of the organization (Gupta and Aggarwal, 2012). Talent management is an internal set of process, programs and cultural norms in an organization designed and enforced to attract, develop, deploy, and hold talent to achieve strategic aims and meet future business demands (Silzer and Dowell, 2010). Talent management helps in covering long-standing practices which aim at getting the right person in the right job in the right time at the right place (Cappelli and Keller, 2014). Talent Management is the number one concern of all top organizations in the world right now (Pachpande and Hinge, 2016). To be able to take advantage of the changing and growing markets, the organization must have right people in place. Having skilled employees implies that organizations must know how to identify, manage, develop keep and get the best out of their right people.

Talent management is concerned with sourcing talent, integrating and aligning talent, developing talent, engaging and rewarding talent, strategically deploying talent, and assuring that there is an adequate talent pipeline to support the business as it moves toward its strategic goals. (Ulrich and Brockbank, 2005).Talent management focuses on developing and retaining skilled talent, and it improves the chance of better recruits at all levels of the organization. However, it is not enough to enhance the performance of an organization; the real success comes when the heart and minds of individuals in an organization are engaged. Talent Management strategies help in getting employees engaged with both heart and minds to their work tasks with complete enthusiasm. Being engaged is something which is more related to employee's hearts than their minds because feelings and emotions drive an individual's behavior. So how employers and organizations make their employees feel fit in their jobs makes a positive impact on their performance (Crowley, 2016).

Concerning public sector banks, it can be observed that they are often faced with competition regarding rewards, remuneration, and selection process than private sector banks. Public sector banks should recruit employees on the merit of their skills and also provide rewards as that helps to gain extra talent from employees. Job rotations and

promotions should be given by performance of employees. That will help employees to provide a better platform to perform well and encourage potential growth. So, talent management strategies may help in developing and fostering a new worker through improved onboarding, developing their potentials and also keeping current workers for a long time and lastly, to attract highly skilled workers for their organization (Bist and Shrivastava, 2013). Today, human resources professionals face vast pressures of acquiring, utilizing, developing and retaining the talented employees in their organizations. It helps to know the employee's abilities, skills, knowledge, experience, intelligence, judgment, attitude, character, drive and ability to learn and grow (Parthasarathy and Zimmermann, 2012). Talent management occupies a significant amount of senior management time, and presently managers struggle to manage talent effectively in organizations. Strategic talent management is an ongoing force of any organization because the mechanism of strategic talent management helps us determine the future demands of our leaders and specify the gap between what we have and what we need. It helps organizations to win in today's competitive era and renew strategies for the challenges of tomorrow (Collings et al., 2011). HR executives and supervisors perceive the effectiveness of talent management and what challenges they observed in their organizations' when they implement the strategies of talent management and how they analyze all positive impacts on human resources outcomes like job satisfaction, motivation, commitment and trust in leaders (Bethke-Langenegger et al., 2011).

### 1.1 OBJECTIVE OF THE STUDY

The objective of the study is to examine the talent management present scenario in Indian public sector banks and identify all those talent management practices which are continuously influencing the job satisfaction and employee performance. To analyze the degree of employee retention, satisfaction, and performance of banks employees at the workplace and provide suggestions for improvement in talent management practices in public sector banks

## II. LITERATURE REVIEW

### Talent Management

Talent management mainly focuses on the employees who identified by the company as a talent. However, there is no universal definition as to what the talent management is (Collings and Mellahi, 2009; Ewerlin and Süß, 2016). All the definitions of talent management include the task of identify, select, develop, appraise, motivate and retain talent to secure the sustainable competitive advantage of the organization (Scullion et al., 2010). We can refer talent management as the activities and processes which involves the systematic identification of the critical position which differentially contribute to the organizations' sustainable competitive advantage, the development of the talent pool of high performing and high potential incumbents to fill these roles and development of the differentiated human resource architecture to facilitate filling those positions with competent incumbents and to ensure their continued commitment to the organization (Collings and Mellahi, 2009, p. 305).

### Job Satisfaction

Job satisfaction is feeling of the contentment that employee feels at the workplace, it's a most popular topic in human resource management. It also becomes the biggest issue of growing concern for all companies throughout the world. When the organization can satisfy their working employees than employees not only continue to stay and work for the organization but also would share the worthiness of the workplace with their respective networks (Tanwar and Prasad, 2016). Job satisfaction is known as the broad conception which is used in different fields to measure or describe employees' feelings towards their organizations' performance, policies, turnover and other factors. It has been recognized that job satisfaction can be impacted by psychological, social and economic factors (Kwak et al., 2010). It can be defined as the extent to which employees satisfied or dissatisfied with their jobs (Spector, 1997). Furthermore, job satisfaction of employees to a large extent contributes to the achievement of the overall objectives and goals of the organization and also creates an impact on the productivity of the organization (Ikone and Onuoha, 2013).

### Employee performance

Job performance refers that how resourcefully an employee takes actions and contributes to the behaviors that are in line with the objectives of the organization (Viswesvaran and Ones, 2000). Performance assessment gives the actual

feedback to the behavioral change towards the increased productivity and the expected performance. Performance assessment in the various forms such as key performance indicators is an objective and systematic process to collect, analyze and use the collected information to determine the level of effectiveness and efficiency of the employees' achievement and duties (Pawirosumarto et al., 2017).

### III. THEORY AND HYPOTHESES

Talent management strategies are not only associated with elevated organizational results but are also a substantial factor in molding employees attitudes. Training and development opportunities create the higher level of motivation for the enhanced discretionary behavior of employees and satisfaction with career development opportunities that eventually lead to improved job satisfaction (Latif, 2012). A job with the advanced scope and potential allied growth leads to improve job satisfaction and performance. Organizations mainly concerned with achieving a better employee performance level at lower cost, gaining satisfaction from their work is the very crucial factor for the better performance of employees (Voordt, 2004). Satisfaction drives commitment, and then we can expect that there will be a high level of organizational commitment on the part of those employees (Preez and Bendixen, 2015). A significant issue limiting the progress of organizations is the difficulty in dealing with the employee satisfaction. It is possible that satisfaction of employee reflects the organizations' financial status (Cao and Chen, 2016). Mainly successful organizations are more likely to have various talent management strategies to increase job satisfaction of employee; the meanwhile higher level of job satisfaction can help motivate employees, which in turn improves organization productivity and profitability. Hence it is hypothesized that:

Talent management is a strategic tool for improving employee performance (Collings and Mellahi, 2009). It outlines four generic philosophies regarding talent management: first, people approach for talent management as categorization of people; second practice approach as the presence of key HRM practices; the third position approach, is the identification of pivotal positions; and, fourth strategic pool approach as internal talent pools and succession planning. The people approach focuses on management of employees whose skills are considered rare, hard to find and difficult to replace by using talent management practices designed to attract, retain and develop high performance and potential of employees (Guthride et al., 2006). People philosophy creates competition between interpersonal and intrapersonal levels. Inter-personal competition needs strategic human resource and talent management strategies and cultural mindset designed to up-skill employees, advocates talent management as leadership imperative and attention on the performance level of employees through categorization of employees by over and underperforming employees (Sears, 2003). Intra- personal competition needs excellent intellectual skills and concerns regarding work tasks, maintaining peak personal performance and avoiding career derailment (Nijs et al., 2014). The positive view of this approach is that everyone has talent and abilities to perform well and can improve the effectiveness of employees; on the other hand, it is also true that high-level performance is not feasible for everyone and hence various investments are expected (Sparrow and Makram, 2015).

Today we consider skilled workforce as human capital which is a combination of knowledge, skills, life experiences, motivation, and capability of the employees. And this helps an organization to achieve goals and drive success and talent management helps in getting skilled and knowledgeable employees or can you could say talent management considers the fuel for the engine of human capital management. A famous Chinese proverb - "*If you wish to grow something for a season, grow mangoes; if you wish to grow something for a year, grow rice, but if you wish to grow something for a lifetime, develop manpower.*" - Says the essence of human resource management. Every person possesses some unique and qualitative talent (Iqbal et al., 2011). In organizations, through talent management practices, human resources professionals assist their employees to enhance their efficiency for work to gain sustainable and competitive growth to attain incredible performance of employees. The high potential of employees leads to higher services, quality, and productivity, which leads to the greater level of customer satisfaction, which leads to higher level of sales, profitability, and shareholders' returns. Thus, talent management is crucial for survival and performance of an organization in the highly competitive business environment. (Kahinde, 2012). Hence it is hypothesized that:

**IV. METHODOLOGY**

We are validating the hypothesized relationships on a sample 380 employees from four large Indian public sector banks; these banks were State Bank of India, Punjab National Bank, Bank of India, and Bank of Baroda. Data collected by administering the self-reported questionnaire. We have chosen these banks because they have different talent management practices that focus on employee satisfaction, and improvement in performance of employees. They also are lining up incentives like paid holidays from abroad, leadership and training programs at top level b-schools. The primary instrument used for collection of data for this research study is the questionnaire method. This method states all facts which directly associate to the factors necessary for the objective of the research. The questionnaire consists of different series of questions which are related to talent management practices, performance, jobsatisfaction, employee retention. The questionnaire is composed of the relation to bank employees. The total 600 questionnaire distributed in the banks and 380 valid responses collected, resulting in the 63 percent of response rate. Data analysis was carried out using inferential analysis of the data which will be conducted by using the structural equation model. Exploratory factor analysis applied in the first stage to identify the model that contains the talent management constructs which have the most significant impact on employee retention, satisfaction, and performance of bank employees by using SPSS 23. In the second stage, the model fitness will be tested through the confirmatory factor analysis by using AMOS 23. The model was then represented in the path diagram and estimated by using the structural equation modeling (SEM) statistical technique.

**V. ANALYSIS OF RESULTS**

**Demographic data of bank respondents**

The salient demographic features such as: gender, age, and education of the employees summarized in Table 1. The majority of those bank respondents where the sample comprised approximately 33 percent of females and 67 percent of males, where male employees are responded more than female employees.

**Table 1: Demographic Data of NBFC Employees**

Demographic Variables	Frequency	Percentage
<i>Gender</i>		
Male	254	66.8
Female	126	33.2
<i>Age (in years)</i>		
21-30	122	32.1
31-40	105	27.6
41-50	108	28.5
51-60	45	11.8
<i>Educational Level</i>		
High school	10	2.6
Bachelors	130	34.2
Masters	226	59.5
Others	14	3.7

**Note:** n = 380

The majority in age group level is approximately about 32 percent employees aged between (21-30 years), other 28 percent employees (31-40 years), 28 percent employees (41-50 years) and 12 percent employees (51-60 years). So the bank respondent of the sample relatively belonged to the young and middle ages. The qualification sample is approximately about 59 percent of bank employees hold a master degree, 34 percent employees hold bachelors' degree, 3 percent employees hold high school degree and rest 4 percent employees hold some other qualification degrees (see table 1). Majority of the bank employees have master's degree in their education.

**Factor Analysis**

**Internal consistency (evidence of reliability)**

Reliability considered as an assumption which needs to be addressed before running the factor analysis. It represents the internal consistency of variables; some researchers claimed that range of reliability must be in  $>.70$ . The reliability analysis of this research study done successfully, where the value of Cronbach's Alpha of items was  $.93 >.70$ , which indicates the higher level of internal consistency of the data.

**Exploratory factor analysis**

The main aim of EFA was to determine the actual condition where links between the latent and observed variables are uncertain or unknown and dimension reduction for the present study has been carried out principle axis factoring along with varimax rotation was executed to arrive the most meaningful solution through software SPSS 23.

**Table 2 : KMO and Bartlett's Test**

Kaiser-Meyer-Olkin Measure of Sampling Adequacy.		.934
Bartlett's Test of Sphericity	Approx.	5563.87
	Chi-	9
	SquareDf	171

The KMO measure verified the adequacy of the sample for analysis. KMO measure was 0.93 which is more than Kaiser's indicated correlations between items, establishing reliability as being on the higher side (see Table 2), and indicated marvelous factor analysis. All communalities in analysis ranged from 0.29 to 0.74. Factor loadings of all 19 items ranged from 0.56 to 0.85 which represents the strong internal consistencies in all items

**Extraction Method: Principal Axis Factoring.**

The result of EFA revealed that eigenvalue of three factors was greater than 1. These three factors accounted for 64.18 percent variance in the analyzed items. It can see in Table 4, where only first three factors have eigenvalues which are greater than 1. The variance explained by each of them is 45.04 percent, 13.16 percent, and 5.97 percent respectively. An initial EFA analysis was run to obtain the eigenvalues for all factors in the data.

**Confirmatory Factor Analysis**

We used the multi-items measures for this research study and performed confirmatory factor analysis by using method maximum likelihood estimation using software AMOS 23. This study had 19 items of 3 factors scale in confirmatory factor analysis. To test the stability of all items, a sample of bank's employees employed from major public sector banks. The confirmatory factor analysis model appeared with 19 item 3 factor model, first model indices as  $\chi^2$  506.43; df 149;  $p < 0.000$ ;  $\chi^2$  /df 3.39; GFI 0.86; AGFI 0.83; NFI 0.91; CFI 0.93; RMSEA 0.08; RMR 0.02. This result reveals modification indices 4.0 to 68.50, inspection of these indices parameters required create covariance in four items in the model.

**Model of Confirmatory Factor Analysis**

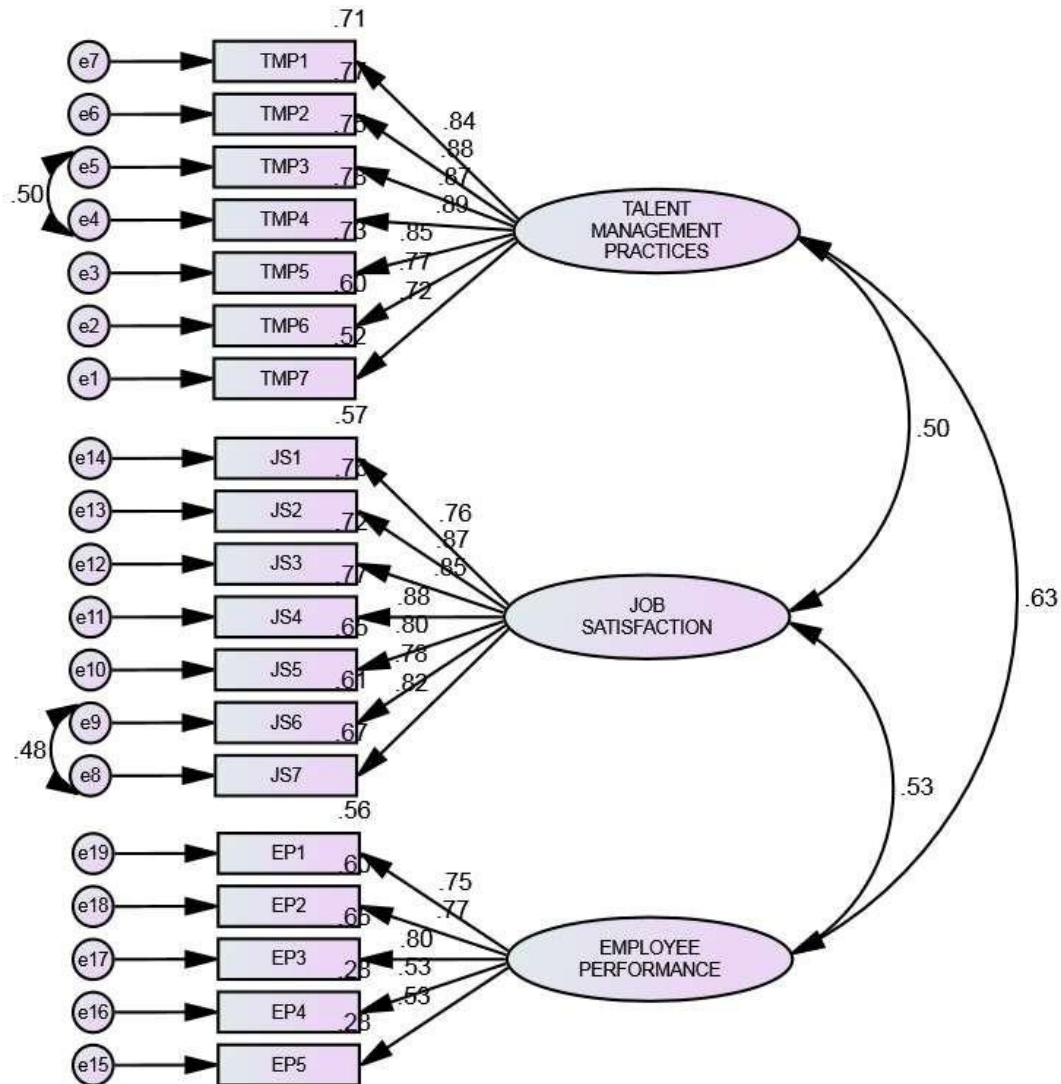

The final CFA model demonstrated good model fit indices as  $\chi^2$  362.59; df 147;  $p < 0.000$ ;  $\chi^2 / df$  2.46; GFI 0.90; AGFI 0.88; NFI 0.93; CFI 0.96; RMSEA 0.06; RMR 0.02. All the modification indices appear significantly low and squared multiple correlations ranged from 0.28 to 0.78 suggested acceptable or good fit. Factor loadings of items were all significantly different from zero ( $p < 0.05$ ) with values ranging from 0.53 to 0.89. Final CFA model (see figure 1) showed the better goodness of fit as compared to the first model of CFA, and the underlying construct correlated with each other.

**Path Analysis Model**

Path analysis of structural equation modeling tests the following relationships among series of the independent and dependent variable. It examines the complex models in a single report. A direct model was tested to see whether talent management practices enhanced the job satisfaction and performance level of employees.

**Path analysis model**

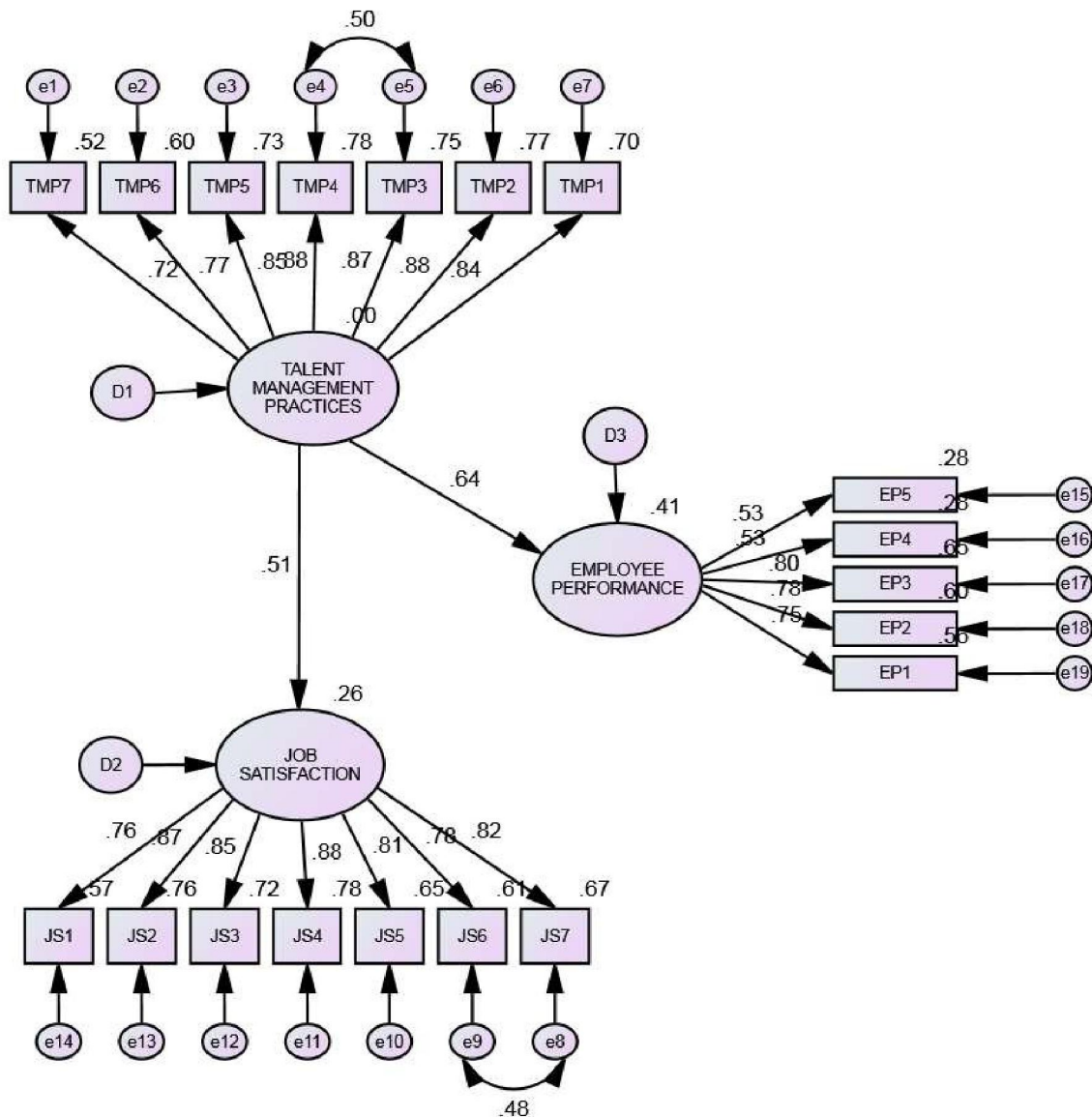

Moreover the final structural model after all modification as shown in figure 2 with standardized estimates, all the path loadings are significant with good indices of model fit  $\chi^2$  389.70; df 148;  $p < 0.000$ ;  $\chi^2 / df$  2.63; GFI 0.90; AGFI 0.87; NFI 0.93; TLI 0.94; CFI 0.95; RMSEA 0.06; RMR 0.04

**VI. FINDINGS AND DISCUSSION**

Path analysis model using the series of multiple regression analysis proves the hypothesized relationship of the different variables identified, which influence public sector banks employees. There were two causal hypotheses. Based on these hypotheses, the identified variables were positioned in the input path diagram. The strength of the standardized regression coefficient and beta weights in each path of path diagram helps to identify which of them are better supported by data. The variable talent management practices in given the model have the direct impact on employees' satisfaction and employees' performance in public sector banks. The first aim of the research study was to examine the extent to which talent management affects the level of job satisfaction in employees, the initial results of this research study demonstrated that talent management practices had the p-value  $< 0.05$  and standard regression coefficient

approximately 51% (TMP= .507). So the standard regression coefficient of talent management practices presented the better effect size on job satisfaction. These findings justified the acceptance of H1 and proposing approximately 26% (Adjusted D2= .257) squared multiple correlations. Further, the second aim of the study was to examine the extent to which talent management practices affect employee performance; the analysis results demonstrated the talent management practices had the p-value < 0.05 and standard regression coefficient approximately 64% (TMP= .639). Thus the researcher accepted the H2 by proposing that approximately 41% (Adjusted D3= .408) squared multiple correlations. So talent management practices have positive impact on both job satisfaction and employee performance, but the level of positive impact of talent management practices is higher on employee performance in comparatively with job satisfaction in public sector banks. So talent management practices provide the better- advanced scope of the job, and potential allied growth leads to improve job satisfaction and performance. Mainly successful organizations are more likely to have various talent management practices to increase job satisfaction of employee; the meanwhile greater level of job satisfaction can help motivate employees, which in turn improves organization productivity and profitability.

## VII. CONCLUSION

To realize the research objectives of the survey, the comprehensive evaluation of the essential empirical and theoretical literature was carried out. The 19 item scale has been developed to measure the level of satisfaction and performance of public sector bank employees in Rajasthan. The result reveals the present situation of employees at banks has been conceptualized and evaluated as the 3-factor construct consisting of talent management practices, job satisfaction, and employee performance. These variables have been hypothesized, and some identified to have the relationship of talent management practices with job satisfaction and employee performance. The research study findings confirmed some of its hypothesis. The talent management strategies are positively and significantly related to the job satisfaction and performance of the employees. Talent management strategies are not only associated with elevated organizational results but are also a substantial factor in molding employee's attitudes. Training and development opportunities create the higher level of motivation for the enhanced discretionary behavior of employees with career development opportunities that eventually lead to employees' satisfaction. The job with the advanced scope and potential allied growth leads to improve employee performance. So employees who are experiencing the higher level of job satisfaction from their organizations are more likely to be productive and less likely to leave the job.

### Limitations of the Study

This research study restricted in scope, this study is only limited to Rajasthan only. It may be helpful to determine if the attitudes and beliefs of the employees to this study are similar to those responding to the same issue in public sector banks in India as a whole. Finally due to the difficulty of the researcher to reach personally to the bank employees the method of the analysis was chosen only quantitative. Further research should also include the qualitative method, based on the interviews with bank employees and their managers.

## REFERENCES

- [1] C. Kwak, B. Y. Chung, Y. Xu, and C. Eun-Jun, Relationship of job satisfaction with perceived organizational support and quality of care among South Korean nurses: a questionnaire survey, *International Journal of Nursing Studies*, 47, 2010, 1292- 1298.
- [2] C. N. Ikonne, and U. D. Onuoha, Factors influencing job satisfaction of librarians in federal and state university libraries in Southern Nigeria, *Open Access Library Journal*, 2, 2013.
- [3] C. Viswesvaran, and D. S. Ones, Perspectives on Models of Job Performance, *International Journal of Selection and Assessment*. 8(4), 2000, 216-226.
- [4] C. X. Cao, and C. Chen, Value of employee satisfaction during the financial crisis, *Managerial Finance*, 42(12), 2016, 1208-1225
- [5] D. Ewerlin, and S. Süß, Dissemination of talent management in Germany: myth, facade or economic necessity?, *Personnel Review*, 45(1), 2016, 142-160.



- [6] D. G. Collings, and K. Mellahi, Strategic talent management: A review and research agenda, *Human Resource Management Review*, 1(4), 2009, 304–313.
- [7] D. G. Collings, H. Scullion, and V. Vaiman, European perspectives on talent management, *European J. International Management*, 5(5), 2011.
- [8] D. S. S. Bist, and N. Shrivastava, Talent Management Scenario in the Banking Industry, *Paripex - Indian Journal of Research*, 2(4), 2013.
- [9] D. Sears, *Successful talent strategies: Achieving superior business results through market-focused staffing*, New York: American Management Association, 2003.
- [10] D. Ulrich, and W. Brockbank, *The HR value proposition*. Boston. MA: Harvard Business School Press, 2005.
- [11] H. Scullion, D. G. Collings, and V. Vaiman, European perspectives on talent management. *European J. International Management*, 5(5), 2011.
- [12] J. M. Theo, and V. D. Voordt, Productivity and employee satisfaction in flexible workplaces, *Journal of Corporate Real Estate*, 6(2), 2004, 133-148.
- [13] J. S. Kehinde, Talent Management: Effect on Organizational Performance, *Journal of Management Research*, 4(2), 2012.
- [14] K. F. Latif, An integrated model of training effectiveness and satisfaction with employee development interventions, *Industrial and Commercial Training*, 44(4), 2012, 211-222.
- [15] K. Tanwar, and A. Prasad, The effect of employer brand dimensions on job Satisfaction: gender as a moderator, *Management Decision*, 54(4), 2016.
- [16] M. Crowley, (2016, February 4). Why Engagement Happens In Employees Hearts, Not Their Minds. Retrieved from <http://www.talentculture.com/>
- [17] M. Gupta, and K. Aggarwal, Talent management strategy: A study of private banks in India, *Asian Journal of Multidimensional Research*, 1(4), 2012.
- [18] P. Bethke-Langenegger, P. Mahler, and B. Staffelbach, Effectiveness of talent management strategies, *European J. International Management*, 5(5), 2011.
- [19] P. Cappelli, and J. R. Keller, Talent Management: Conceptual Approaches and Practical Challenges., *Annu. Rev. Organ. Psychol. Organ. Behav.*, 2014.