

# Air Quality Monitoring and Controlling Using IOT

**Ms. Biswas. M. S<sup>1</sup>, Srushti Bhinge<sup>2</sup>, Aarti Bandagar<sup>3</sup>, Rutuja Dhekane<sup>4</sup>**

Assistant Professor, Department of Electrical Engineering<sup>1</sup>

UG Students, Department of Electrical Engineering<sup>2,3,4</sup>

SVERI's College of Engineering, Pandharpur, Maharashtra, India

**Abstract:** *Smart cities are growing as a crucial area of research on an international level; they improve infrastructure to address issues brought on by the high rate of development. With Arduino's assistance, this system is cheap and simple to construct, and it operates relatively efficiently in locations with medium traffic. The public plays a significant role in deciding on policies to fight air pollution. To encourage public recognition of the duty and some form of action is a crucial role in any society. The studies determined the pollution level; if the level exceeds the permissible level, a decision is made to notify the authorities, who can use this information to plan preventive actions and take steps to halt the ongoing negative effects of air pollution and prevent the evolution of developments in technology are beneficial to us; in our current surroundings, air pollution monitoring systems play an important role since they directly affect our daily lives. The government determines the acceptable emission limits in accordance with Bharat Stage standards. The level of a vehicle's emissions rises as a result of incorrect maintenance. The owner of the car will be warned of the dangerous levels of pollution when the emission levels of the vehicle grow. There will be emissions from every car. Emissions cannot be totally avoided, but they may be tracked and managed with the use of an embedded pollution detection system. In order to provide some insightful ideas for the sustainable growth of urban traffic, it focuses on learning some achievable strategies for managing and effectively reducing urban traffic pollution.*

**Keywords:** Air Quality

## I. INTRODUCTION

The term "air pollution" refers to the act of contaminating the air with compounds that are hazardous to humans and other life forms. Fossil fuel use has resulted in a considerable rise in worldwide CO<sub>2</sub> emissions over the past few decades, raising worries about the environment and the economy. These issues include climate change, health effects, and global warming. Since 1970, carbon emissions have grown by nearly 90% , with emissions from industrial operations and the burning of fossil fuels accounting for around 78% of the entire increase in greenhouse gas emissions. being able to identify pollution. 34 of these previous fatalities were caused by air pollution. Air pollution is one of the main types of pollution. One of the fundamental components of a person's environment is air. The atmosphere of the planet is made up of gases like nitrogen, oxygen, carbon monoxide, and minute amounts of some rare elements. An environment with clean air is essential for humans. The lives and health of people depend greatly on this. Any alteration to the air's natural composition might be extremely harmful to the earth's living forms. The presence of one or more pollutants in the atmosphere, such as gases, at an amount that is harmful to people, animals, and plants is referred to as air pollution. ppm and ug/m<sup>3</sup> are the units used to measure air pollution. The direct atmospheric release of primary contaminants occurs. When a main pollutant interacts with other substances, secondary pollutants are created. Air pollution can make it harder to breathe, cause coughing, and aggravate asthma and emphysema. Visibility might also be hampered by polluted air. One in eight premature deaths globally occurs as a result of air pollution each year. killing 7 million people. Every year, indoor and outdoor pollution, secondhand smoking, and respiratory infections cause almost 570,000 deaths in children under the age of five.

## II. LITERATURE REVIEW

The idea of air pollution monitoring may be trendy right now. We have begun implementing our idea for "Air Pollution Detection Using Embedded Systems" by analysing various documentation and methods of using many pollution detectors. The following papers were reviewed for literature: This section provides an overview of many current technologies. Many techniques for detecting air pollution have been created using various methodologies. Many tasks have been completed. The results of the studies provided the pollution level; if the pollution level exceeds the acceptable level, it is decided to notify the authorities. who can use this information to plan preventive actions and take steps to halt the ongoing negative effects of air pollution and stop this phenomenon's evolution. The development of technologies benefits us, and in the current environment, air pollution monitoring systems are crucial. It directly affects human life. There will be emissions from every car. Emissions cannot be totally avoided, they can be monitored and managed with the help of an embedded system for pollution detection.

Monika Singh et al.; (2019) proposed; This system senses the many types of gases present in the environment using an Arduino microcontroller linked with MQ135 and MQ6 gas sensors. It was then linked to the Wi-Fi module, which connects to the internet. An LCD is used to show the user the output. and a buzzer sounds a warning when the ppm exceeds a particular threshold. Industrial perimeter monitoring, interior air quality monitoring, site selection for reference monitoring stations, and data dissemination were some of its uses. Yamuna Thangam et al.; (2018) used IoT by measuring the concentration of gas using various sensors which were observed through serial monitor of Arduino. This data is collected in Thing speak channels by means of Ethernet shield which is available in live for further processing. these analysed results were viewed through thing speak in a graphical format.

Poonam Pal et al.; (2017) created a system utilising an Arduino microcontroller to monitor the air. They used an Arduino to manage the entire operation and a MQ135 gas sensor to detect various harmful gases. The output from the MQ135 gas sensor is provided in the form of voltage levels, which must be translated into PPM. The entire process was connected to the internet via a Wi-Fi module, and an LCD was used to display the results visually. The buzzer starts blaring, and the LCD and webpage display "Poor Air, Open Windows" when the PPM exceeds the limit. When the number is less than 1000 PPM, the LCD and webpage display "Fresh Air." If it goes over 2000, the buzzer will continue to beep. and "Danger! Move to Fresh Air" will be displayed on the LCD and webpage.

## III. NEED OF PROJECT

Good air quality is an important habitable indicator for a healthy community. Air pollution can cause diseases, allergies, and even death to humans; it can also cause harm to other living organisms such as animals and food crops, and may damage the natural environment. Poor air quality may limit people's ability or opportunity to be physically active. The greatest sources of CO to outdoor air are cars, trucks and other vehicles or machinery that burn fossil fuels

### 3.1 Objective

The project's goals are to demonstrate opposition to air pollution, which is currently the leading contributor to global warming. The most frequent causes of air pollution are things like greenhouse gases and vehicle exhaust. The north pole's icecaps will ultimately melt and the water level will increase, engulfing low-lying nations like Singapore if air pollution is not reduced. Animals like polar bears will be killed by it. We wish to eliminate air pollution since it harms many creatures and the ozone layer. By working on this project, we can inform the public of the drawbacks of transportation air pollution and provide information on how to lessen it. then the project will warn people about cons of traffic air pollution and its reduction.

## IV. SCOPE OF PROJECT

The gadget we currently have can be made more compact in the future by shrinking the size of the device. Detecting the quantity of pollution from automobiles that can be detected is necessary for future implementation or improvements that may be made. Industries may monitor air quality and detect the presence of these toxics using air quality monitoring systems, allowing them to make informed decisions about how to enhance the air quality for their employees. As a result, output rises, equipment damage declines, and regulations are effectively followed.

**V. PROPOSED METHODOLOGY**

In this project, we'll build an IoT-based air pollution monitoring system that will track air quality via an internet-connected web server and sound an alarm when it drops below a certain threshold, which occurs when harmful gases like CO<sub>2</sub>, smoke, alcohol, benzene, and NH<sub>3</sub> are present in sufficient quantities. On the LCD and on the website, the air quality will be shown in PPM for easy monitoring. A smoke detector with a MQ2 sensor and an air quality analyser ; however, this time we've chosen the greatest air quality sensor: the MQ135. The ability of air quality to properly measure and detect the majority of dangerous gases with this IOT project, you may use a PC or a mobile device to check the pollution level from anywhere. This system may be installed anywhere, and it can also activate a device—for example, turning on the exhaust fan or notifying the user through Blynk IOT when pollution levels exceed a certain threshold.

**5.1 Algorithm/Steps in developing the project**

- Step 1: Component choosing
- Step 2: Arduino uno Program Coding
- Step 3: Circuit Drawing
- Step 4: Code Dumping
- Step 5: Simulating the Circuit
- Step 6: Final Result comparison

**5.2 Components**

- MQ2 sensor MQ135
- Node MCU
- Battery
- LED
- Buzzer

**5.3 Block Diagram**

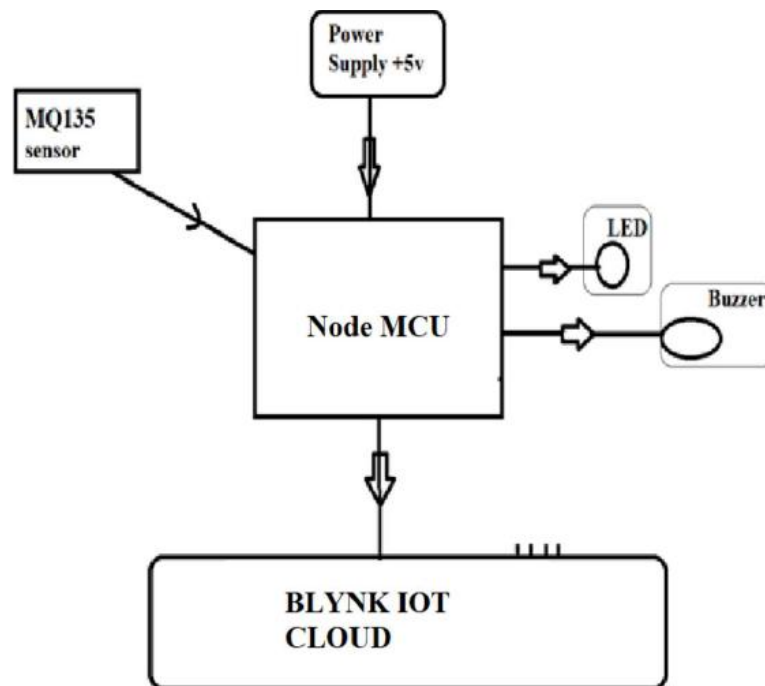



**V. RESULT**

Pollutant	Min	Mean	Median	Max	S.D.
CO	0	0.74	0.5	64.13	1.68
NO	0	28.43	13	916.2	44.12
NO <sub>z</sub>	0	15.88	12	474.5	16.04
NO <sub>x</sub>	0	43.33	27.44	978.75	51.87
O <sub>3</sub>	0	24.19	24.5	237.5	11.63
PM <sub>0</sub>	0	12.15	10	291	9.02
PM <sub>z5</sub>	0	15.08	12.73	731	12.87
PM <sub>10</sub>	0	46.45	25.5	2640	97.36
SO <sub>2</sub>	0	8.53	4.1	283	10.92

**VI. CONCLUSION**

This program monitors all sorts of air pollution via the internet, enabling prompt alerting of nearby people. Many lives might be saved from terrible situations consequently. An air pollution monitoring system will be used to address any environmental problems. According to this study, an advanced air pollution monitoring system continually checks the quality of the air in a given location and displays the results on an LCD screen. The technique aids in raising awareness of the everyday air one breaths. This monitoring tool can provide air quality measures in real time.

**REFERENCES**

- [1]. H. Chourab, T. Nam, S. Walker, J. R. Gil-Garcia, S. Mellouli, K. Nahon, et al., "Understanding smart cities: an integrative framework", 45th Hawaii International Conference on System Sciences, Jan. 2012. mblisher: IEEE

- [2]. K. Gupta and R. P. Hall, "The Indian perspective of smart cities", Smart City Symposium Prague (SCSP), May 2017.
- [3]. Y. Mehmood, F. Ahmad, I. Yaqoob, A. Adnane, M. Imran and S. Guizani, "Internet-of-Things- Based Smart Cities: Recent advances and challenges", IEEE Communications Magazine, vol. 55, no. 9, pp. 16-24, 2017.
- [4]. S. B. Sharma, S. Jain, P. KhirwadLar and S. Kulkarni, "The effects of air pollution on the environment and human health", Indian Journal of Research in Pharmacy and Biotechnology, vol. 1, no. 3, pp. 391-396, May-June 2013.
- [5]. Zanella, N. Bui, A. Castellani, L. Vangelista and M. Zorzi, "Internet of Things for Smart Cities", IEEE Internet of Things Journal, vol. 1, no. 1, pp. 22-32, Feb. 2014.
- [6]. F. K. Shaikh, S. Zeadally and E. Exposito, "Enabling technologies for green Internet of Things", IEEE Systems Journal, vol. 11, no. 2, pp. 983-994, June 2017.
- [7]. R. L. Baggam, "Smart City with Internet of Things", International Journal of Advanced Research in Computer Science, vol. 8, no. 5, pp. 1242-1245, May — June 2017.
- [8]. R. Al-Ali, Imran Zualkernan and Fadi Alou1, "A Mobile GPRS-Sensors Array for Air Pollution Monitoring", IEEE Sensors Journal, vol. 10, no. 10, pp. 1666-1671, Oct. 2010.
- [9]. M. Ibrahim, A. El-Zaar and C. Adams, "Smart sustainable cities roadmap: Readiness for transformation towards urban sustainability", Sustainable Cities and Society, vol. 37, pp. 530-540, February 2018.
- [10]. Simon E. Bibri, "The IoT for smart sustainable cities of the future: An analytical framework for sensor-based big data applications for environmental sustainability", Sustainable Cities and Society, vol. 38, pp. 230-253, April 2018.