

Smart Waste Management System

Prof. N. J. Jadhav, Aaditya Anil Karandikar, Sandesh Yashwant Bhadane, Vedant Prakash Amle, Prathamesh Sanjay Aher

Department of Mechanical Engineering
JSPM's Rajarshi Shahu College of Engineering, Pune, India

Abstract: This research paper proposes a smart garbage management system using LabVIEW to address the issue of overflowing dustbins and garbage cans in public spaces in India. The system aims to keep dry and wet garbage separate and provide real-time information on the status of garbage bins, reducing the need for frequent waste collection trips. Waste management, including sorting, transportation, processing, recycling, and disposal, is crucial in densely populated areas. The paper highlights the pressing need for effective waste management due to the significant amount of waste generated in India. The lack of proper garbage collection and transportation infrastructure in Indian cities poses challenges for waste management and contributes to the spread of diseases. The proposed system aims to prevent waste overflow and improve waste management practices in India.

Keywords: waste overflow, LabVIEW, real-time monitoring, waste separation, waste collection, waste disposal, waste recycling.

I. INTRODUCTION

For better life outcomes in India, the environment needs to be clean and hygienic. In the current situation, it frequently occurs that the dustbins or garbage cans located in public spaces in cities are overflowing as a result of the daily growth in waste. These overflowing trash cans can produce an unpleasant odour and lead to an unclean atmosphere. Because of this, germs and viruses that can cause various diseases thrive quickly. In order to apply distinct processes—composting, recycling, and incineration—to different types of garbage, the proposed system will assist keep dry and wet garbage separate and inform users to the status of garbage bins. By alerting people when garbage is full then number of trips of the vehicle who are collecting waste garbage should get reduced.

rubbish management involves sorting, moving, processing, recycling, or eradicating waste, as well as monitoring rubbish items. The management of waste is a highly important issue that has grown in importance as a result of the dense population. Municipal Corporation has created a productive strategy for managing rubbish to lessen its impact. The amount of waste produced per person in India ranges from 200g to 500g. According to numerous organizations, each Indian produces 1.3 to 1.5 pounds of garbage. In 2001 alone, 47 million tons of trash were reportedly produced. The amount has gone up to 95 million tons in the last two years. In comparison to other countries, Indian cities perform poorly when it comes to rubbish collection. As a result, the Indian government is having trouble managing the rubbish. Due of population growth, disposal problems have gotten more difficult. The accumulation of waste in all areas and places of the city is the result of inadequate garbage collection and poor transportation infrastructure. Municipal trash management is becoming critically important as a result of these inaccessible facilities. In addition, improper rubbish management causes life forms to contract fatal diseases. Therefore, "Smart Management of Garbage Using LabVIEW" has been suggested to prevent waste overflow.

II. LITERATURE REVIEW

A smart dustbin based on IoT was proposed by [1], and it was developed on a platform based on an Arduino Uno board that was connected to a GSM modem and an ultrasonic sensor. The bin's top was where the sensor was positioned. A 10 centimeter threshold was established. The sensor activates the GSM modem when the rubbish level reaches the threshold, alerting the appropriate authority until the bin is emptied. In the end, it was determined that when these smart bins were designed, a number of challenges, including affordability, maintenance, and durability, were addressed. Additionally, it helped create a clean and hygienic environment as part of the process of creating a smart city The

researchers [2] suggest the following method for managing garbage. A microcontroller-based system with IR wireless technologies and a central system that showed the amount of garbage in the bin at any one time was connected to the trash can. The status was viewed on a mobile web browser using Wi-Fi, which showed an HTML page. To reduce expenses, they merely used weight-based sensors and a Wi-Fi module on the sender's side to broadcast and receive data. Ultimately, the sensor was only able to determine the volume of waste present in the bin by looking at its weight. The author suggested a system for planning the rubbish collection in urban commercial and residential regions [3]. The ultrasonic sensor in this system measured the amount of trash in the bin and sent the information to the control panel using the GSM module. To check the data connected to the garbage for various sites, a GUI was also created; however, this GUI was different because it was built on MATLAB. That are two present units in the system ; the master unit was in the control room, and the slave unit was in the garbage. The sensor will measure the amount of trash and relay the information to the slave unit, which will then send it to the master unit. In this study, a decision support system was developed for application in city rubbish collection[4]. This system took care of the inefficient waste collection in the city's difficult-to-reach neighborhood's. In the urban areas where there were the most issues, cameras were installed. There were two parts in the systems. The first part involved locating businesses that engaged in waste collection, owned trucks, and had the ability to hire drivers to collect trash from around the city and transport it to landfills or recycling facilities. The second step was to create a system that could manage all conversations between all parties and keep track of the data. Around the city, various trash cans were positioned, each with an inexpensive embedded gadget that tracked the amount of trash within [5]. Each bin has a unique ID, making it simpler to identify which bin needs to be emptied when it is full. Two pieces make up the project: one is the transmitter section and the other is the receiving section. The garbage level is checked by sensors in the transmitter portion, which transmits data to the system via an RF transmitter, which is then received by an RF receiver and sent to the related client so that the bin can be emptied.

II. METHODOLOGY

Block diagram of proposed system:

As depicted in the figure, the IOT garbage monitoring system is constructed using an Arduino board platform and the IOT Gecko web development platform.8. Compost is strengthened with an ultrasonic sensor and is interfaced with a Wi-Fi modem. Hardware components include a 12V transformer, an AVR family microcontroller, LEDs, LCD displays, and resistors, capacitors, and diodes. IOT Gecko, MC Programming Language C, and the Arduino compiler are included in the software.

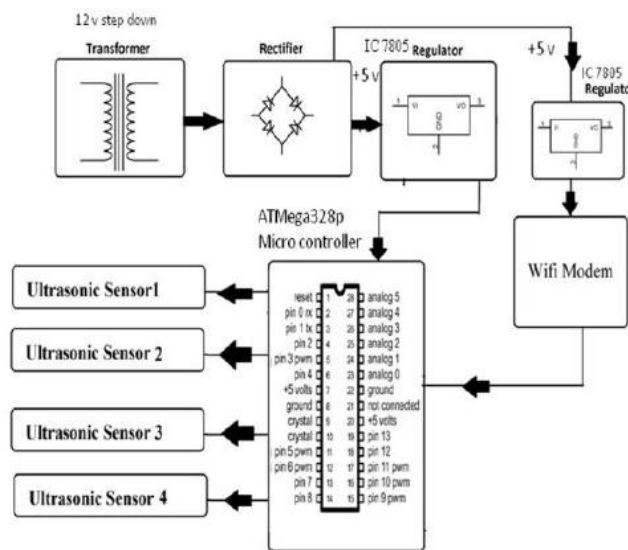

Fig No 1: Block Diagram.

Transformer, therapy, controllers, wifi modem, AVR microcontroller, and ultrasonic detectors are all shown in the block illustration. The Ultrasonic detectors are connived with the Ultrasonic detectors and placed over the trash barrels

to measure the volume of trash that has been gathered there. The microcontroller and wifi modem participated an interface. The step down motor receives the force(230V 50 Hz ac), steps it down into 12V ac, and also delivers its affair to the therapy.

Interspersing current is converted into direct current(AC to DC) by the therapy. Both of the controllers admit the therapy affair.

Regulator's main ideal is to keep affair voltage constant. One affair from the controller is transferred to the microcontroller directly, and another affair from the controller is transferred via wifi modem. The Block Diagram is shown Below fig No.1

III. HARDWARE USED:

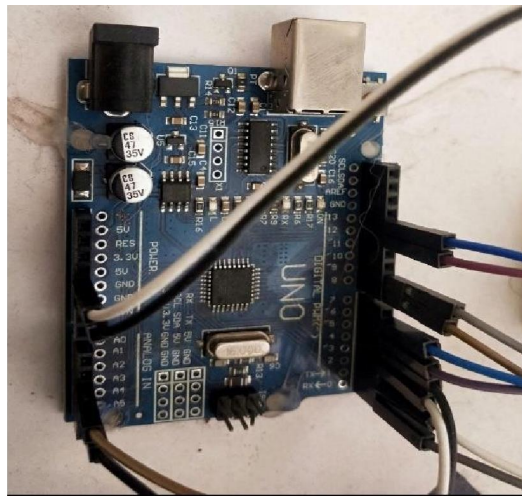

Fig No 2: Arduino Uno Board

Ultra Sonic Sensor:

Wearing an ultrasonic sensor allows you to calculate the detachment with high accuracy and consistent readings. At a frequency of 40 KHz in the air, it can measure detachment ranging from 2 cm to 400 cm, or from 1 inch to 13 feet, and if an object gets in the way, it will spring back to the feeler. The Ultrasonic Sensor is depicted in Figure No 3.

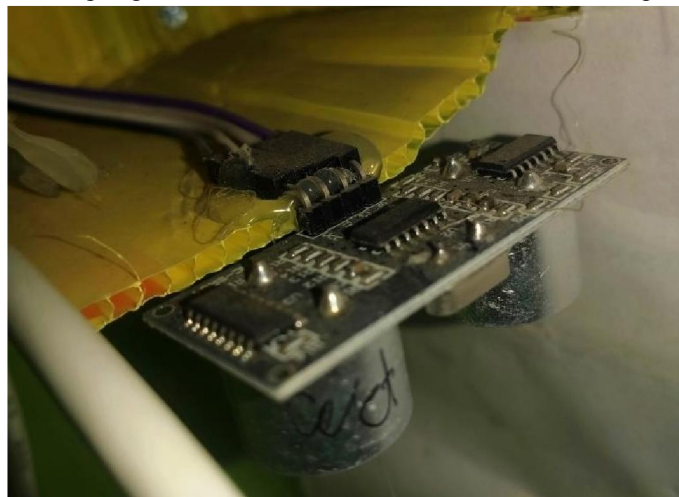

Fig No 3: Ultra Sonic Sensor.

GSM modem:

Figure No 4 depicts a GSM modem.If the garbage can rises above the predetermined threshold level, signal number 11 is used to notify the garbage depots.

We can send quick text messages to the required municipal office using the GSM module interface. The GSM module is supplied by the SIM card used by the mobile service provider, which sends SMS messages to the appropriate authorities in accordance with programme. It uses the 900 MHz or 1800 MHz frequency bands for operation.



Fig No 4: GSM Modem.

Microcontroller:

It processes the data that the sensor sends to it. Based on a comparison between the received data and the threshold level, the output is produced. The 16/32-bit ARM7TDMI-S CPU that powers the LPC131/32/34//38 microcontrollers has concurrent emulation and embedded outline holdup. As a result, the microcontroller has access to 32KB, 64KB, 128KB, 256KB, and 512KB of embedded flash memory. A 128-bit wide memory interface and a single accelerator structural design enable 32-bit code to run at the greatest clock rate.

WI-FI MODEM:

This unit has enough built-in processing power and storage to enable GPIO integration with sensors and other application- specific devices with little to no setup required beforehand and little to no loading needed during runtime. Little additional circuitry is possible because to the extensive on-chip integration, and even the frontend module was designed to take up little PCB real estate. The ESP8266 comes with a self- calibrated RF that enables it to operate in all operational circumstances without the need for additional RF components. Additionally, it has Bluetooth coexistence limits and APSD for VoIP claims.

The enormous community support has enabled many of the nearly limitless number of sequences that are available for the ESP8266. The ESP8266 Module requires an external Logic Level Converter since it cannot shift logic from 5 to 3 volts. Never power a device straight from a 5V development board.

IV. SYSTEM ARCHITECTURE

A very innovative device that will help keep cities clean is the IOT Garbage Monitoring system. This technology monitors the trash cans and delivers alerts via a website on how much garbage is amassing in them. To accomplish this, an array of ultrasonic sensors mounted above The depth of the bins and the amount of trash within are measured and correlated using the bins. The device has a buzzer, an LCD display, a Wi-Fi modem for data transmission, and an Arduino-compatible microcontroller. The system is run by a transformer with a 12V supply.

The LCD monitor displays the status of the amount of rubbish that has been gathered in the bins.

However, a web page is made so that the user viewing it can see the status. The website offers a graphic representation of the trash cans and emphasises the waste collected in colour to show the amount of trash that has been collected.

When the amount of trash produced exceeds the typical threshold, the plan triggers the signal. Thus, by keeping the public informed about the trash levels in the bins and providing a visual representation of the bins on a website, this method helps to maintain the city clean. The ESP8266 Wi-Fi Module, a self-contained SOC with an integrated TCP/IP protocol stack, allowing any microcontroller to connect to your Wi-Fi network. The ESP8266 is capable of hosting a submission or taking over complete Wi-Fi networking responsibilities from another application processor. An AT command standard firmware is already pre-programmed onto each ESP8266 module.

An extremely affordable board with a huge and expanding community is the ESP8266 module. Fig. No. 5 shows the architecture of the suggested system.

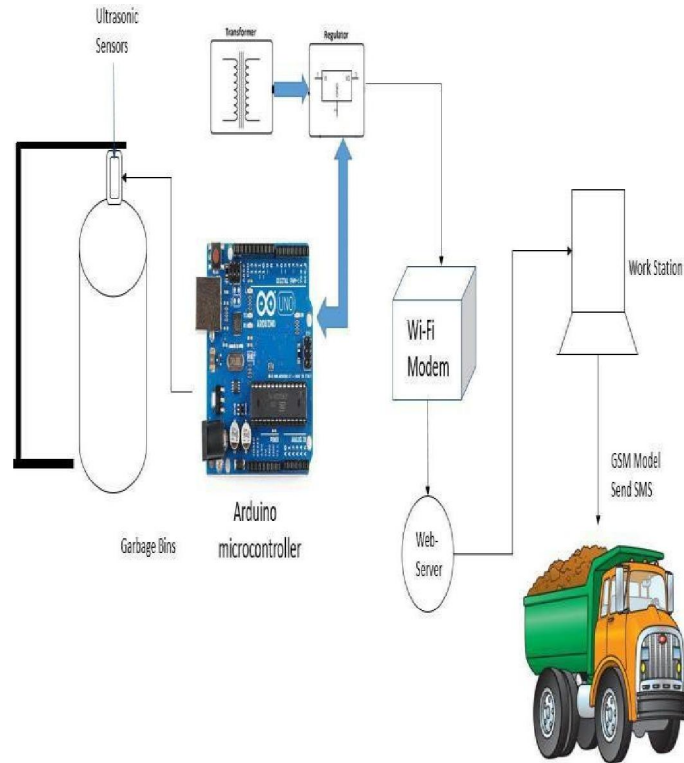

Fig No 5: System Architecture

Flow chart:

In Fig. No. 6, the flow chart is displayed. The waste container is initially empty, and sensors are placed above the bins to measure how much trash has gathered there. If the sensor finds no trash in the bin, it gives the person observing in the control room no information. In any other case, the sensor shows a graph of the level if it detects trash in the bin and the level is between 0% and 70%. The buzzer will sound every 10% if the level is between 70% and 100%. After providing information to the concerned party in the control room, it then gives the individuals instructions to collect the waste.

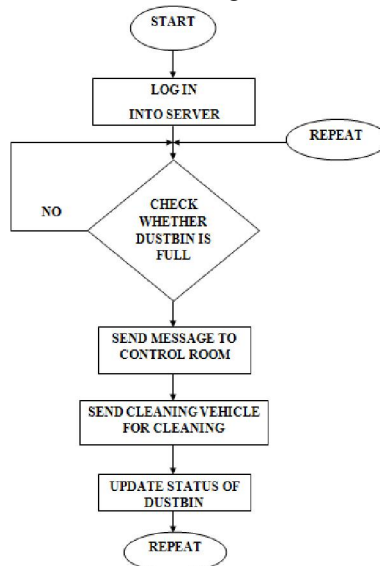

Fig No 6: Flow Chart.

VI. RESULT AND DISCUSSION

These are the outcomes of this work, as shown below.

Measuring the amount of waste within the trash can.

We are providing data wirelessly to the recipient.

the data can be accessed to anyone and anywhere.

The access to and transmission of data in real time.

Prevents the trash can from overflowing. In many ways, this IoT-based garbage management is incredibly beneficial for smart cities. We have observed that different dustbins are dispersed around cities in various locations, and that certain dustbins are overflowing. several times, yet the individuals who should know about this never do. Our technology is built to address this problem and will provide comprehensive information about the trash cans scattered throughout the city

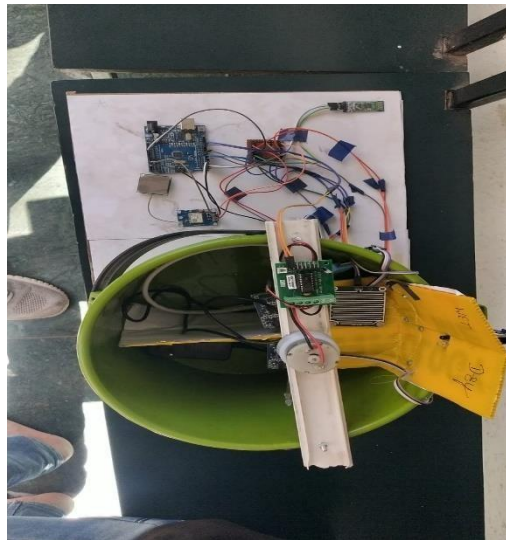

Fig No 7: Diagram

VII. CONCLUSION AND FUTURE WORK

This article demonstrates the implementation of waste management utilising sensors, LabVIEW, and GSM. This essay offers a method for achieving waste management. When the trash can is entirely full, this technique aids in keeping it clean. The current garbage collection facility and management system are insufficient for the needs of the time. Therefore, greater rubbish collection and transportation facilities need to be offered. This technology minimises the frequency of the waste collection vehicle's arrival because it notifies the user when the trash can is entirely full. Finally, this technique contributes to environmental preservation. As a result, garbage collection is improved in efficiency.

The primary goal is to maintain the city's degree of cleanliness and create a better living environment. Using this method, we can continuously monitor the amount of trash in the trash cans that are distributed across the city. Employees can be alerted when a specific dustbin reaches its capacity limit so they can take prompt action to empty it as soon as feasible. On their mobile phones, the staff members may always check the status of these dumpsters. If implemented properly, this approach could prove to be incredibly helpful.

People who want to go one step further for improving cleanliness might utilize the system as a standard.

REFERENCES

- [1].Anitha A, Garbage Monitoring system using IoT, IOP Conference Series Material Science and Engineering
- [2].V.Ashwin Raaju, J.Malappillai Meeran, M.Sasidharan, K.Premkumar, IOT BASED SMART GARBAGE MONITORING SYSTEM USING ZIGBEE, IEEE publication
- [3]Waste Management as an IoTEnabled Service in Smart Cities, by Alexey Medvedev, Petr Viktorovich Fedchenkov, Theodoros Thodoris Anagnostopoulos, and Sergey Khoruzhnikov, was published by researchgate

[4].IOT-BASED GARBAGE MONITORING SYSTEM by Dr. K. Alice Mary, Perreddy Monica, A. Apsurrunisa, Chathala Sreekanth, and G. Pavan Kumar⁵ was published in Volume 8 of the International Journal of Scientific & Engineering Research.

[5].Bharadwaj B, M Kumudha, Gowri Chandra N, and C haithra G, "SWACHH BHARAT ABHIYAN" - A PRACTICAL APPROACH: AUTOMATION OF SMART WASTE MANAGEMENT USING IoT," published by 2017 Second International Conference On Computing and Communications Technologies (ICCCT17).