

# Dynamic Robot for Seed Sowing with Insect Killer Spraying on Seed

Mr. A. H. Ansari<sup>1</sup>, Sagalgile Ashwini<sup>2</sup>, Ritika Sagar<sup>3</sup>, Murtadak Ashwini<sup>4</sup>

Professor, Department of Electronics and Telecommunication<sup>1</sup>

Students, Department of Electronics and Telecommunication<sup>2,3,4</sup>

Pravara Rural Engineering College, Loni, India

**Abstract:** In India, near about 70% people are dependent upon agriculture. So the agricultural system in India should be advanced to reduce the efforts of farmers. Various number of operations are performed in the agriculture field like seed sowing, weeding, cutting, pesticide spraying etc. Very basic and significant operation is seed sowing. But the present methods of seed sowing are problematic. The equipments used for seed sowing are very difficult and inconvenient to handle. So there is a need to develop equipment which will reduce the efforts of farmers. This system introduces a control mechanism which aims to drop seeds at particular position with specified distance between two seeds and lines while sowing. The drawbacks of the existing sowing machine will be removed successfully in this automatic machine. Agriculture is the backbone of Indian economy. About half of the total population of our country has chosen agriculture as their chief occupation. The states like Maharashtra, Punjab, and Kerala, Assam are highly involved in agriculture. equipment has been developed. The pesticide sprayer is one among them and it is done by traditional farm workers by carrying backpack type sprayer, which requires human effort or by using electric pump. To improve the agriculture system and to reduce the human effort and problems associated with the backpack sprayer new equipment is fabricated which will be beneficial to farmers. The equipment utilizes renewable energy source (Solar energy) which is eco-friendly to function. The solar panel gives out electric supply to system, the radio-controlled transmitter and receiver minimize drudgery of farmer. Also minimize the wastage of pesticide and time. Our contribution on our project is by using eco-friendly reliably available solar energy as a main source of energy making this multifunctional sprayer device by advancing the spraying methods which make friendly to use and operate which can be useable in different spraying stages of farming as per process requirement. It can be operated in small farming land with the standard spacing decreasing the labor cost and human effort.

**Keywords:** Bluetooth Module, Microcontroller, L293D motor Driver IC, insect killer Sprayer, Solar Power

## I. INTRODUCTION

Agricultural robots are the fastest growing technology developed to perform various complex tasks that are difficult for humans to achieve. This “Dream project” was planned to involve unmanned tractors working in the farm on the disaster site. The robotic farmers are capable of cultivating vegetables, fruits, soybeans, wheat and rice, which are then packed in boxes and shipped across the country by this robotic technology. This process is accompanied by recycling of carbon dioxide using machinery in an attempt to reduce the use of fertilizers.

A single solution to implement precision agriculture is the development of a single gantry robot that can perform several precision agriculture related operations. The main objective of this system is to implement soil monitoring and precision irrigation on each crop, perform de-weeding and design a cultivated field using accurate robotic crop planning.

The idea of robotic agriculture (agricultural environments serviced by smart machines) is not a new one. Many engineers have developed driverless tractors in the past but they have not been successful as they did not have the ability to embrace the complexity of the real world. Most of them assumed an industrial style of farming where everything was known before hand and the machines could work entirely in predefined ways – much like a production line. The approach is now to develop smarter machines that are intelligent enough to work in an unmodified or semi

natural environment. These machines do not have to be intelligent in the way we see people as intelligent but must exhibit sensible behavior in recognized contexts.

sprayers such as easy to operate, maintain and handle, it facilitates uniform spread of the chemicals, capable of throwing chemicals at the desired level, precision made nozzle tip for adjustable stream and capable of throwing foggy spray, light or heavy spray, depending on requirement. Agriculture sector is facing problems with capacity issues, shrinking revenues, and labour shortages and increasing consumer demands. Renewable Energy is generally defined as energy that comes from long lasting resources. The sun is the most abundant and unlimited source of energy. As solar energy is one of the most important non-conventional sources of energy. This energy is environmentally friendly, which is mainly free from pollution. Solar energy get from the sun is harvested on the solar panel the panel is made up of photovoltaic cells, which converts energy from photon to electric. And these cells are made up of silicon semiconductor. Solar panel is used to store electric energy or charge the battery from the solar energy. And the battery charged is used to operate DC pump for spraying the pesticides. The prevalence of traditional agriculture equipment intensifies these issues. In addition, most farmers are desperately seeking different ways to improve the equipment quality while reducing the direct overhead costs (labour) and capital. Thus, a significant opportunity rests with understanding the impact of a pesticide sprayer in an agriculture field. A pesticide sprayer has to be portable and with an increased tank capacity as well as should result in cost reduction, labour and spraying time. In order to reduce these problems, there are number of sprayers introduced in the market but these devices do not meet the above problems or demands of the farmers.

## **II. NEED OF PROJECT**

Agriculture is a very important sector in Indian economy. Most of the livelihood in India depends on agriculture. As the knowledge based farm labours are less, the requirement for them is high and their wages are increasing. Traditionally farming is done by human being with the help of bullock carts, tractors and tillers etc. The main problem in agricultural field include lack of labor availability, lack of knowledge regarding soil testing, increase in labor wages, wastage of seeds and more wastage in water. The idea of applying robotics technology in the field of agriculture is very new. In agriculture, the opportunity for robot-enhanced productivity is more and the robots are appearing on farms in various guises and in increasing numbers.

## **III. LITURATURE REVIEW**

To Previously, this literature review explains about relevant past research and project development which is used the almost similar system for this project.

1. Shailesh Malonde et al “Design and Development of Multipurpose Pesticides Spraying Machine” IJAEGT Volume 04

Pesticide spraying is the necessary procedure in cultivation of the crops. The present idea deals with the designing and fabricating a pesticide sprayer which will be useful and affordable to the farmers which will assist to increase the productivity of crops. Though this project an attempt has been done to improve the method of spraying the pesticide that will enhance the productivity and increase the farmer’s income. So we have designed a pesticide spraying machine which will not only increase productivity but also will reduce the effort of the farmers. The machine will save the time of the farmer as well as efficiency in spraying. This model carries multi nozzle pesticides sprayer pump which will perform spraying at maximum rate in minimum time. Constant flow valves can be applied at nozzle to have uniform nozzle pressure.

2. Pandurang Lad et al “Solar Operated Pesticide Sprayer” IJARSE Volume 04A

Solar Operated Pesticide Sprayer is a pump running on electricity generated by photovoltaic panels or the thermal energy available from collected sunlight as opposed to grid electricity or diesel run water pumps. The operation of solar powered pumps is more economical mainly due to the lower operation and maintenance costs and has less environmental impact than pumps powered by an internal combustion engine (ICE). Solar pumps are useful where grid electricity is unavailable and alternative sources (in particular wind) do not provide sufficient energy. The solar panels make up most (up to 80%) of the systems cost. The size of the PVsystem is directly dependent on the size of the pump,

the amount of water that is required and the solar irradiance available. The solar sprayer has many advantages. Besides reducing the cost of spraying, there is a saving on fuel/petrol.

3. Dr. H. Erdal Ozkan et al. The main goal of this study was to design and develop software and hardware for an intelligent sprayer that can control variable-rate spray outputs through the nozzles based on availability of a target in sight and density level of the canopy sprayed. This has been accomplished to a large degree. However, there is still some ineffectiveness associated with the operation of this sprayer that can be addressed by future studies.

4. C.Umayaal et al. This paper deals with the exposition of how robotics can be applied to various phase of agriculture. One of the most important occupations in developing country like India is agriculture. It is very important the efficiency and productivity of agriculture by replacing labours with intelligent machine-like robots using latest technologies. The paper proposes a new strategy to replace humans in various agricultural operations like detection of presence of pests, spraying of pesticides, spraying of fertilizers etc thereby providing safety to the farmers and precision agriculture.

5. Poratkar et al. The working of this manually operated multi nozzle pesticides sprayer pump is based on the principles of motion transmission due to chain and sprocket arrangement and plunger cylinder arrangement. The operator first stand behind the trolley. He will grab the handle and lift it and push the trolley forward. As trolley move forward, the wheel rotates in counter clockwise direction. As sprocket is mounted on same shaft of wheel, it also rotates in counter clockwise direction. This motion is transferred to freewheel via chain drive arrangement. The free-wheel, thus, also starts rotating in counter clockwise direction. As freewheel and big spur gear are mounted on same shaft, it also start rotating in anticlockwise direction. 6. A.S. Wankhede et al. The Equipment is especially made to work in row crops such as cotton pulses etc. of an agricultural field. The economic condition of farmers and the cost of labor, owing to such conditions, this equipment can find its application. The equipment is intended to perform three important operations done in fields, namely, spraying pesticide, spraying herbicide and applying urea. All the three operations can be performed simultaneously or individually. Application of urea to the crops is not being focused much by various agriculture equipment producing firm and the equipment available are mostly suitable for large field which are in hectares. Moreover, whatever methods are available for applying urea results in high wastage of urea, we have focused on the same.

#### IV. PROPOSED SYSTEM

Fig 1 below shows the overall project's flow chart of the system

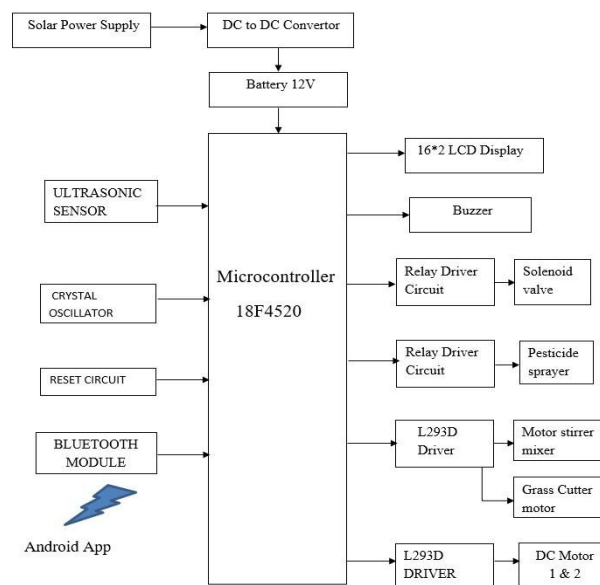

Fig. 1. Block Diagram

The Microcontroller is the brain of the desired system. It consists of two sections one is transmitter section and another is receiver section. In transmitter section it consists of Bluetooth device whereas Bluetooth, Solar panel, ultrasonic

sensor, and Storage battery which works as input. In receiver section it consists of Microcontroller, LCD, L293D Motors driver IC, Relays, Grass Cutter, Buzzer, Stirrer Motor, Sprinkler motor, Solenoid Valve, DC motor. The sun rays are collected by the solar panel, where it converts solar energy into electrical energy and it is stored in the storage battery. We use here automatic solar panel rotation system according to intensity of light to catch maximum solar energy. By using Bluetooth, we send instructions/commands to the microcontroller unit.

The operation takes place in the microcontroller unit to display commands on LCD display therefore we can operate the complete operation such as sprinkler motor, solar movement, mixer, solenoid valve and L293D motors for movement of the prototype.

#### A. PIC 18F4520 Microcontroller

It is an 8-bit enhanced flash PIC microcontroller that comes with nanoWatt technology and is based on RISC architecture. Many electronic applications house this controller and cover wide areas ranging from home appliances, industrial automation, security system and enduser products. This microcontroller has made a renowned place in the market and becomes a major concern for university students for designing their projects, setting them free from the use of a plethora of components for a specific purpose, as this controller comes with inbuilt peripheral with the ability to perform multiple functions on a single chip.

Data Memory up to 4k bytes Data register map - with 12-bit address bus 000-FFF

Divided into 256-byte banks

There are total of F banks

Half of bank 0 and half of bank 15 form a virtual (or access) bank that is accessible no matter which bank is selected – this selection is done via 8-bit

Program memory is 16-bits wide accessed through a separate program data bus and address bus inside the PIC18.

Program memory stores the program and also static data in the system.

On-chip External

On-chip program memory is either PROM or EEPROM.

The PROM version is called OTP (one-time programmable) (PIC18C) The EEPROM version is called Flash memory (PIC18F).

Maximum size for program memory is 2M n Program memory addresses are 21-bit address starting at location 0x000000



Fig 2. PIC18F4520

#### B. Bluetooth Module

Bluetooth wireless technology is becoming a popular standard in the communication. it is one of the fastest growing fields in the wireless technologies. It is convenient, easy to use and has the bandwidth to meet most of today's demands for mobile and personal communications. Bluetooth technology handles the wireless part of the communication channel; it transmits and receives data wirelessly between these devices. It delivers the received data and receives the data to be transmitted to and from a host system through a host controller interface (HCI). The most popular host controller interface today is either a UART or a USB. Here, I will only focus on the UART interface, it can be easily show how a Bluetooth module can be integrated on to a host system through a UART connection and provide the designer an optimal solution for Bluetooth enabled systems.

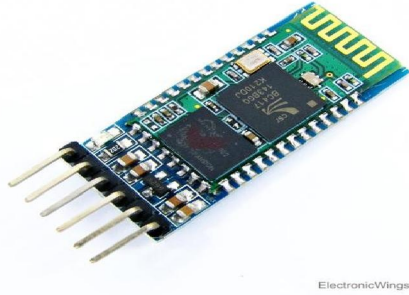

Fig 3. Bluetooth Module

### C. Ultrasonic Sensor

Ultrasonic ranging module HC -SR04 provides 2cm -400cm non-contact measurement function, the ranging accuracy can reach to 3mm. The modules include ultrasonic transmitters, receiver and control circuit. The basic principle of work:(1) Using IO trigger for at least 10us high level signal. (2) The Module automatically sends eight 40 kHz and detect whether there is a pulse signal back. (3) IF the signal back, through high level , time of high output IO duration is the time from sending ultrasonic to returning. Test distance = (high level time) \* (velocity of sound (340M/S) / 2.



Fig 4. Ultrasonic Sensor

### D. LCD Display

LCD (Liquid Crystal Display) screen is an electronic display module and find a wide range of applications. A 16x2 LCD display is very basic module and is very commonly used in various devices and circuits. These modules are preferred over seven segments and other multi segment LEDs. The reasons being: LCDs are economical; easily programmable; have no limitation of displaying special & even custom characters (unlike in seven segments), animations and so on.

A 16x2 LCD means it can display 16 characters per line and there are 2 such lines. In this LCD each character is displayed in 5x7 pixel matrix. This LCD has two registers, namely, Command and Data. The command register stores the command instructions given to the LCD. A command is an instruction given to LCD to do a predefined task like initializing it, clearing its screen, setting the cursor position, controlling display etc. The data register stores the data to be displayed on the LCD.

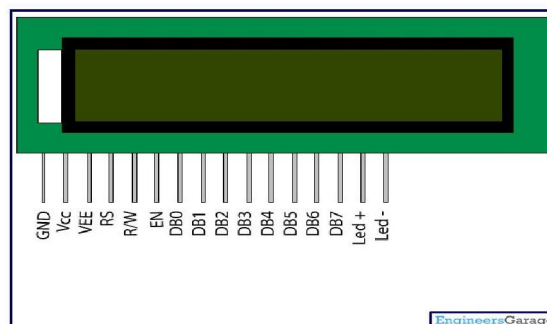

Fig 5. LCD Display

**E. L293D Motor Driver IC**

A motor driver is an integrated circuit chip which is usually used to control motors in autonomous robots. Motor driver act as an interface between controller and the motors. The most commonly used motor driver IC's are from the L293 series such as L293D, L293NE, etc. These ICs are designed to control 2 DC motors simultaneously. L293D consist of two H-bridge. H-bridge is the simplest circuit for controlling a low current rated motor. We will be referring the motor driver IC as L293D only. L293D has 16 pins.

The L293D is a 16 pin IC, with eight pins, on each side, dedicated to the controlling of a motor. There are 2 INPUT pins, 2 OUTPUT pins and 1 ENABLE pin for each motor. L293D consist of two H-bridge. H-bridge is the simplest circuit for controlling a low current rated motor.

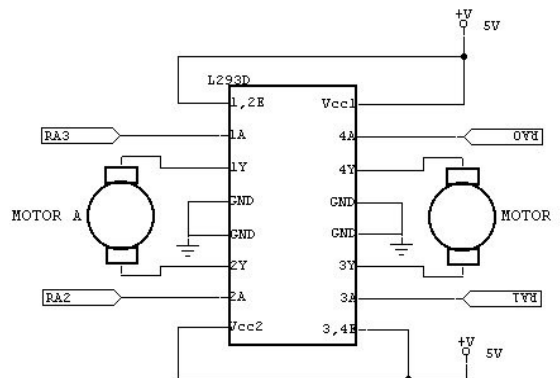

Fig 6. L293D Motor Driver IC

**A. Relay Driver Circuit**

A relay driver circuit is a circuit which can drive, or operate, a relay so that it can function appropriately in a circuit. The driven relay can then operate as a switch in the circuit which can open or close, according to the needs of the circuit and its operation. Now that we're using a transistor to drive the relay, we can use considerably less power to get the relay driven. Because a transistor is an amplifier, we just have to make sure that the base lead gets enough current to cause a larger current to flow from the emitter of the transistor to the collector. Once the base receives sufficient power, the transistor will conduct from emitter to collector and power the relay.

With no voltage or input current applied to the transistor's base lead, the transistor's emitter-to-collector channel is open, hence blocking current flow through the relay's coil. However, if sufficient voltage and input current are applied to the base lead, the transistor's emitter-to-collector channel will close, allowing current to flow through the relay's coil.

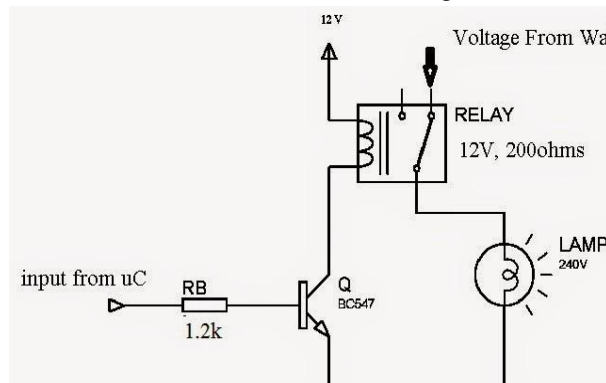

Fig 7. Relay Driver Circuit

**V. CONCLUSION**

In this project we tried to overcome the problem of farmers which they face in day to day life. Since we know that wages of farmers is too high, and after spending their whole day in the farm land their production is found less. So we had made an automated robot which will be a helping hand to the farmers in field. Observing the current scenario this

prototype robot can provide high efficiency in production and their cultivation. This robot can do multitasking which is lots of time consuming when done by manual based method farming. It can sow seed, spray fertilizers and also levelling of the surface. This project can be a better substitute for the human who performs these sowing and fertilizing. This project is very useful for the farmers who are intended to do agriculture activity but facing the labor problem

#### VI. ACKNOWLEDGEMENT

It gives us great pleasure in presenting the paper on “Dynamic Robot For Seed Sowing With Insect Killer Spraying On Seed” We would like to take this opportunity to thank our guide, Prof. A.H. Ansari, Professor, Department of Electronics and Telecommunication Engineering Department, Pravara Rural Engg. Collage, Loni for giving us all the help and guidance we needed. We are grateful to him for his kind support, and valuable suggestions were very helpful

Result

Sr.no	Command	Observation
1	1	Movement in forward direction
2	2	Movement in backward direction
3	3	Turn left
4	4	Turn Right
5	5	Seed sowing
6	6	Seed spraying

#### REFERENCES

- [1] Ranjitha B, Nikitha M, N, Aruna K, Afreen, B T Venkatesh murti “ Solar Powered Autonomous Multipurpose Agricultural Robot Using Bluetooth/Android App”, IEEE 2019
- [2] Maheswari R, Azath H, Sharmila P, Sheeba Rani Gnanamalar S “ Smart village: Solar Based Smart Agriculture with IoT Enabled for Climatic Change and Fertilization of Soil”, IEEE 2019
- [3] Gokul, R. Diksith, M. Gopinath, S. Ajith Sundaresh “ Gesture controlled Wireless Agricultural Weeding Robot”, IEEE 2019
- [4] Y Nikhil Kumar, M Koteswarrao, Ch Haswanth, Rahul raj, Promaanonyachakrobarty, M himakiran, Dr. Gopi Krishna saramekala “ Automated Seed Sowing AgriBot”, IEEE 2019
- [5] Mr. Shaik kareem Mulla, Edwin Prajwal, B. Sujeshkumar, Bonu Mahesh, Balapanuri Vamseedhar Reddy “ GPS based Autonomous Agricultural Robot”, IEEE 2018
- [6] K Durga Sowjanya, R Sindhu, M Parijatham, K Srikant, P. Bhargav “ Multipurpose Autonomous Agricultural Robot “, IEEE 2017
- [7] Sourabh umarkar, Anil Karwankar “ Automated Seed Sowing AgriBot using Arduino”, IEEE 2016