

GSM Based Transformer Healthcare Monitoring with Overload Alert and Protection

Prof. J. R. Rokde¹, Chavan Gayatri², Deokar Priti³, Gadhe Pratiksha⁴, Satpute Punam⁵

Department of Electrical Engineering
Amrutvahini College of Engineering, Sangamner, India

Abstract: *The blockchain typically described as a decentralized system in which transactional or ancient statistics are recorded, stored, and maintained throughout a peer-to-peer community of personal computers referred to as nodes. Counterfeit drugs are one consequence of such limitations within existing supply chains, which not only has serious adverse impact on human health but also causes severe economic loss to the healthcare industry. Blockchain technology has gained tremendous attention, with an escalating hobby in a plethora of several applications like safe and relaxed healthcare records management. Similarly, blockchain is reforming the traditional healthcare practices to an extra reliable means, in phrases of powerful prognosis and treatment through safe and cosy facts sharing using SHA Hash Generation Algorithm. Within the future, blockchain will be an era that can probably assist in personalized, authentic, and at ease healthcare by means of merging the entire actual-time scientific information of a patient's fitness and offering it in an up-to-date cosy healthcare setup. In this paper, we evaluation each the present-and modern-day trends inside the subject of healthcare with the aid of imposing blockchain as a model. We also talk the packages of blockchain, at the side of the demanding situations confronted and destiny views. The proposed system executed blockchain implementation in distributed computing surroundings and it gives the automated restoration of invalid chain by using Consensus and Mining Algorithm. In this system, we present a Custom blockchain-based approach leveraging smart contracts and decentralized off-chain storage for efficient product traceability in the healthcare supply chain. The smart contract guarantees data provenance, eliminates the need for intermediaries and provides a secure, immutable history of transactions to all stakeholders. We present the system architecture and detailed algorithms that govern the working principles of our proposed solution. We perform testing and validation, and present cost and security analysis of the system to evaluate its effectiveness to enhance trace-ability within pharmaceutical supply chains.*

Keywords: Blockchain Technology, Decentralization / Decentralized System, Distributed Computing, Peer-to-Peer Network, Healthcare, Supply chains, etc

I. INTRODUCTION

In recent years increase emphasis has placed on Powers reliability & economy. In particular major change in utility industries have caused increased interest in more economical and reliable method to generate & transmit & distributes electric power. In this regards monitoring the health of equipment's constituting the Systems is critical to assure that the supply of power can be meet the demand. As has seen recently inner Then grid failures on 30 than d31st July 2012 due to Inefficient load management function lead to wide Black out, leaving almost 700 million peoples without Electricity in six northern state of our country. The main concern with transformers protections Is protecting the transformers against internal fault & Ensuring security of the protections scheme for external fault. System condition that indirectly affects transformer often receive less emphasis when transformers protections is specified. Overloading power transformer beyond the nameplate rating can causes arise in temperature of both transformers oil & winding. If the windings temperature is exceed the Transformers limit, the insulation will deteriorate & may Be fail prematurely. Prolonged the rmal heating weaken the insulations over time, resulting in accelerated transformers loss of life. Power systems fault external to the transformers zone can cause high level of current flowing through the transformers. Through faults current create forces with in the transformers that can eventually weaken the winding integrity. A comprehensive transformers protection scheme need to include

protection against transformers over load, through fault, and over excitation, as well as protection for internal fault.

II. LITERATURE SURVEY

In most power companies, for online monitoring of power transformers, use supervisory control and data acquisition (SCADA) system, but for online monitoring of power transformer, the extending the SCADA system is an expensive proposition. Power transformers are currently monitored manually, where a person visits a transformer site, for maintenance and taking records purpose. But main drawbacks of these systems are, it cannot provide information about overloads (Voltage & Current) and overheating of transformer oil & windings. Due to these, the transformer life is reduced.

Monika Agarwal et al. [1] This paper represents that they are designing a system where there exists communication between system and operator. For this we are using Transformer, microcontroller, logic level converter and GSM i.e. global system for mobile communication modem. This GSM modem helps to monitor transformer health by sending message to the system.

Hongyan Mao, et al. [2] This paper represents a large number of power distribution transformer stations and they are faraway from city, wireless GPRS transmission provides a good communication solution to supervise power distribution transformer stations. The scheme of remote wireless monitoring system for power distribution transformer station based on GPRS wireless network was designed in this paper. A control terminal system implement was mainly given, which adopted LPC2132 as main processor, GR47 as the date communication module. The monitor terminal software and flow chart were also designed. At last, the way of configuring the GPRS module to connect network is analyzed.

Pathak A.K, et al. [3] This paper represents a design and implementation of a mobile embedded system to monitor and record key parameters of a distribution transformer like load currents, oil level and ambient Modem, with a standalone single chip microcontroller and different sensors. It is installed at the distribution transformer site and the above parameters are recorded using the analog to digital converter (ADC) of the embedded system. The obtained parameters are processed and recorded in the system memory. If any abnormality or an emergency situation occurs the system sends SMS (short message service) messages to the mobile phones containing information about the abnormality according to some predefined instructions programmed in the microcontroller. This mobile system will help the transformers to operate smoothly and identify problems before any catastrophic failure. Disadvantage of Existing System 1. Firing of transformer can easily occurs. 2. Not accurate. 3. Frequency interference in system. 4. Noise problem in network.

III. PROPOSED SYSTEM

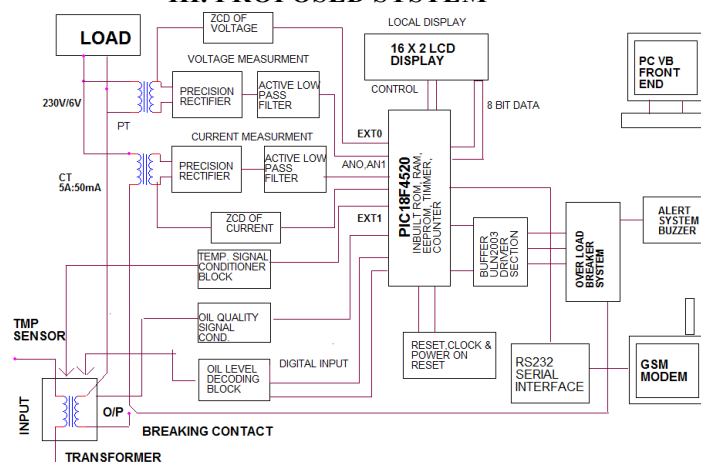

IOT BASED SUBSTATION HEALTHCARE MONITORING AND PROTECTION

Fig. 1. Block Diagram

The main objective of this proposal is to acquire live data of transformer health remotely over the internet using Internet of Things (IOT) technology. We are going to monitor the transformer parameter such as temperature, current and voltage. These data will be sent over internet using MQTT protocol. In case of any power failure the user will be notified with an alert message using GSM Module. It also has a unique feature of detecting the phase failure. If any phase gets defect then it will be indicated in the development board by an LED.

3.1 PIC 18F4520

It is a low-power, high-performance CMOS 8-bit microcomputer with 32K bytes of Flash Programmable and Erasable Read Only Memory (PEROM). The device is manufactured using MICROCHIP high-density non-volatile memory technology.

3.2 Phase Voltage Measurement Block

This block senses the phase voltage. In our project we are doing the simulation by using DC signal. In reality for sensing the phase we have to use PT (Potential Transformer) which converts 230 Vac into 12 Vac.

The output of PT is given to signal conditioning block. This block has rectifier, filter and regulator. The rectifier will convert AC into DC. This DC has some AC ripples, so a Capacitor filter is used to remove the AC ripples. The output of filter is pure DC 12 volts. But microcontroller requires only + 5Vdc. Therefore, we are using Zener of 5 volts. So when phase is present we are getting +5 Vdc and when phase is not present we are getting logic zero i.e. zero volts.

3.3 Phase Current Measurement Block

This block senses the phase current. In reality for sensing the phase current, we have to use CT (Current Transformer) which converts 5A primary current to proportional 50ma secondary current. The output of CT is given to the signal conditioning block. This block has a rectifier, and filter. The rectifier will convert AC into DC. This DC has some AC ripples, so a Capacitor filter is used to remove the AC ripples. The output of the filter is pure DC.

3.4 Frequency Measurement Block

This block is implanted using zero-crossing detectors of voltage and current. By measuring the pulses between one sec time we can calculate the frequency of the signal.

3.5 Oil Quality Measurement Block

The oil quality of the transformer can be measured using IR pair. LED and detector. Pure Oil is transparent; its quality may be defined by its transparency which changes the conduction of the IR detector.

3.6 GSM Modem

A GSM modem is a specialized type of modem which accepts a SIM card, and operates over a subscription to a mobile operator, just like a mobile phone. From the mobile operator's perspective, a GSM modem looks just like a mobile phone. A GSM modem can be a dedicated modem device with a serial, USB, or Bluetooth connection, or it may be a mobile phone that provides GSM modem capabilities. A GSM modem could also operate a GSM mobile phone with the appropriate cable and software driver to connect to a serial port or USB port on your computer.

3.7 Power Supply

For our project, we require + 5 Volt and + 12 Volt supply. + 5 Volt is required for the phase sensor and microcontroller board. And + 12 Volt supply is required to drive Relay.

3.8 LCD Display

The LCD display is used to display the status of the system such as voltage, current, frequency, oil level, temp, and oil quality. For our project work, we require a 16 X 2 LCD display.

IV. RESULT AND CONCLUSION

Following photograph shown actual model of our project:

The GSM-based monitoring of distributions Transformers is quite useful as compared to the manual Monitoring & also it is reliable as it is not possible to Monitor always oil level, oil temperature is e, ambient temperature rise and load current manually. After receiving a message of any abnormalities, we can take action immediately to prevent any failure of a distribution transformer. In a distribution network, there are many distributions transformer & associating each transformer such a system, we can easily figure out that which transformers is undergoing fault from message sent to mobile. We need not have to check all transformer & corresponding phase current & voltage& thus we can recover system in less time. The time for receiving messages may vary due to public GSM network traffic but still then it is more effective than manual monitoring.

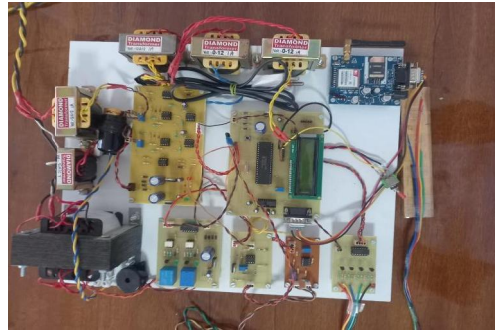

Fig. 2. Photograph of hardware.

V. ACKNOWLEDGMENT

It gives us great pleasure in presenting the paper on “IOT based real time healthcare monitoring of substation transformer with overload alert and protection”. We would like to take this opportunity to thank our guide, Dr. Sridhar Khule Professor, Matoshri Collage of Engg. Research Center, Nashik for giving us all the help and guidance we needed. We are grateful to him for his kind support, and valuable suggestions were very helpful.

REFERENCES

- [1]. Monika Agarwal and Akshaypandya, “GSM Based Condition Monitoring of Transformer”, IJSRD - International Journal for Scientific Research & Development| Vol. 1, Issue 12, 2014 | ISSN (online): 2321- 0613
- [2]. Hongyan Mao, “Research of Wireless Monitoring System in Power Distribution Transformer Station Based on GPRS”, Volume 5, C 2010 IEEE,978-1-4244-5586-7/10/\$26.00
- [3]. Pathak A.K, Kolhe A.N, Gagare J.T and Khemnar SM, “GSM Based Distribution Transformer Monitoring And Controlling System”, Vol-2 Issue2 2016, IJAR IIE-ISSN (O)-2395-4396.
- [4]. J. H. Estrada, S. Valencia Ramí rez, C. L. Cortés, E. A. Cano Plata, "Magnetic Flux Entropy as a Tool to Predict Transformer's Failures", Magnetics IEEE Transactions on, vol. 49, pp. 4729-4732, 2013, ISSN 0018-9464
- [5]. Chan, W. L, So, A.T.P. and Lai, L., L.; “Interment Based Transmission Substation Monitoring”, IEEE Transaction on Power Systems, Vol. 14, No. 1, February 2014, pp. 293-298.
- [6]. Zhang Xin, Huang Ronghui, Huang Weizhao, Yao Shenjing, Hou Dan & Zheng Min, “Real-time Temperature Monitoring System Using FBG Sensors on immersed Power Transformer”, DOI:10.13336/j.10036520.hve.2014.S2.048, Vol.40, Supplement 2: 253-259v, August 31, 2014.
- [7]. Performance Monitoring of Transformer Parameters in (IJIREEICE) Vol. 3, Issue 8, August 2015.
- [8]. GSM based Transformer Condition Monitoring System Ms.Swati R.Wandhare, Ms.Bhagyashree Shikkewal Special Issue-2 ISSN : 24541311 International Conference on Science and Engineering for Sustainable

Development (ICSESD 2017)(www.jit.org.in)International Journal of Advanced Engineering, Management and Science (IJAEMS).

[9]. Leibfried, T, “Online monitors keep transformers in service”, Computer Applications in Power, IEEE, Volume: 11 Issue: 3, July, 2017. International Journal of Pure and Applied Mathematics Special Issue 963

[10]. Chan, W. L, So, A.T.P. and Lai, L., L.; “Interment Based Transmission Substation Monitoring”, IEEE Transaction on Power Systems, Vol. 14, No. 1, February 2014, pp. 293-298.

[11]. Zhang Xin, Huang Ronghui, Huang Weizhao, Yao Shenjing, Hou Dan & Zheng Min, “Real-time Temperature Monitoring System Using FBG Sensors on immersed Power Transformer”, DOI:10.13336/j.10036520.hve.2014.S2.048, Vol.40, Supplement 2: 253-259v, August 31, 2014.

[12]. Performance Monitoring of Transformer Parameters in (IJREEICE) Vol. 3, Issue 8, August 2015