

# IoT Based Smart Dustbin

Kiran Kirpal<sup>1</sup>, Bhagyalaxmi Akudari<sup>2</sup>, Rinku Behara<sup>3</sup>, Shewetang Telang<sup>4</sup>, Prof. Devashri Raich<sup>5</sup>

Students, Department of Information Technology<sup>1,2,3,4</sup>

Professor, Department of Information Technology<sup>5</sup>

Rajiv Gandhi College of Engineering Research and Technology, Chandrapur, India

**Abstract:** Every person in this world throws waste in the form of plastics, wet waste, dry waste and etc. Also, every person looks for a place or a plastic container to dispose that waste, that plastic container is the Dustbin which they look for. Dustbin is a plastic container where everyone can dispose their waste. Dustbin is used as a storage place to dispose waste, but we cannot estimate the exact amount of waste disposed by a society, and the dustbin cannot take more waste as the space should be available in it to take more. We need to know the level of waste in the dustbin and based on that we can intimate people to use the dustbin or not. In this Smart Dustbin project, we have designed a prototype where the lid of the dustbin is opened, on detection of human hand and waste, and the level of waste available inside the dustbin is sent as notification in the form of LED. The main components we used in making this prototype are Arduino, NODEMCU, Servo Motor and Ultrasonic Sensors. The software component is the application named as Blynk which is used to get notification. This dustbin can be a start to Smart Waste Management System where the officials can clean or empty the dustbin which depends on the notification received by them and not waiting for a call from a person of a society who informs the garbage trucks to come and take the waste from them.

**Keywords:** Dustbin, Smart Dustbin, Arduino, NODEMCU, Servo Motor, Ultrasonic Sensor, Blynk, Smart Waste Management System

## I. INTRODUCTION

Dustbin is the storage container used for disposing waste by each and every person in the world. The main thing they look in their surroundings for disposing waste is the Dustbin. Smart Dustbin is just a normal bin where everyone can dispose waste but integration of some hardware components is done for more efficient use of it. Smart Dustbin is integrated with some hardware components such as Arduino, NODEMCU, Servo Motor, Ultrasonic sensors. These components help in opening the lid, on detection of human hand and waste and also sending the notification in the form of LED. The code required to perform the above-mentioned operation is dumped in Arduino and NODEMCU.

### 1.1 Existing System

In existing method the ULTRASONIC SENSOR and MOTION SENSOR is used. Automatic lid opening and closing method is used in smart dustbin and microcontroller programming is done in the system.

### 1.2 Proposed System

One of the sensor uses an Ultrasonic signal to monitor the level of garbage in the dust bin and if the level exceeds the set point a warning signal is sent to the concerned Authorities based on an Arduino program and another sensor senses the odour around the dust bin. Thus a hygiene environment is maintained. GSM module and GPS modem are used for signal transmission and for tracking the location respectively.

## II. METHODOLOGY AND WORKING

This method is proposed to make the city clean and neat. In this method the Ultrasonic sensor senses the level of the garbage in the dustbin and as it reaches alarming levels a message is sent to the concerned authorities. In some cases, the level is not full but it causes some bad smell in that situation also the dustbin needs to be cleaned and it is detected

by using gas sensor and it will send message to the registered mobile number these interfaces are connected to the ARDUINO

### III. CIRCUIT DIAGRAM

The circuit diagram for smart dustbin is represented as

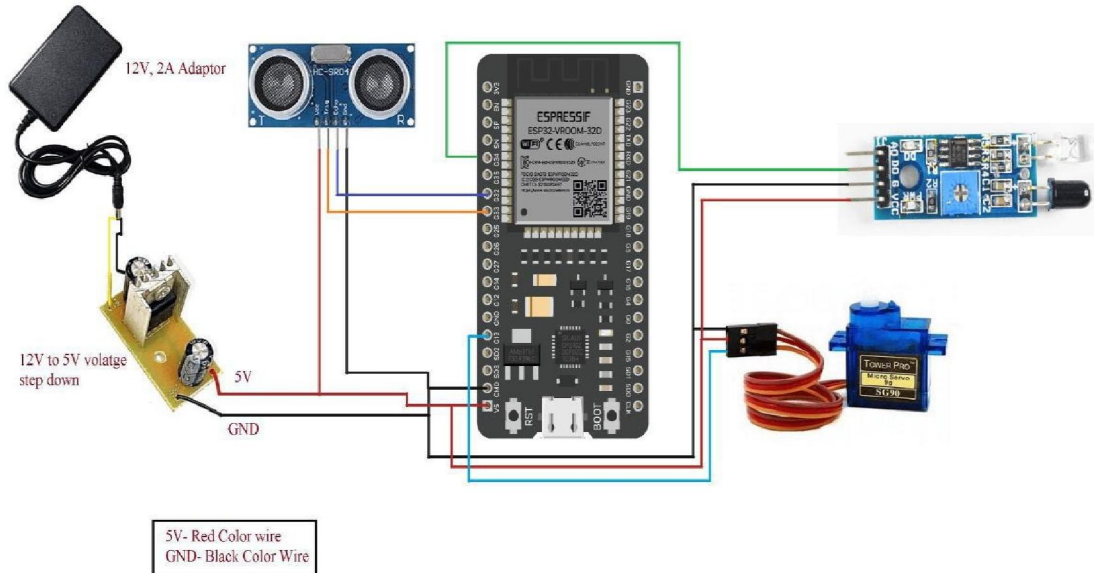

#### INTERFACING LCD MODULE TO ESP 32 WITH I2C ADAPTER MODULE.

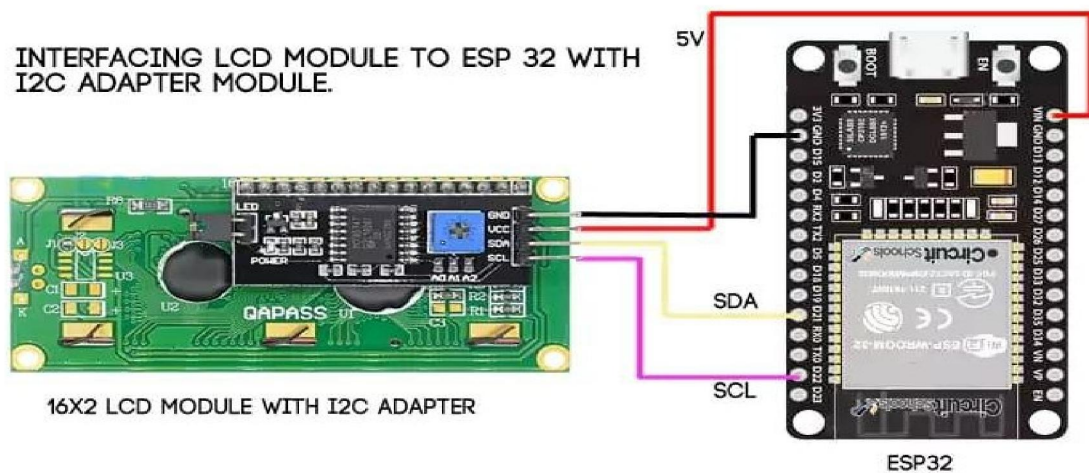

### 3.1 Methodology

#### a) Software Description

The software requirements for this project are Blynk app.

i) **Blynk App:** Blynk is a Platform with IOS and Android apps to control Arduino, Raspberry Pi and the likes over the Internet. It's a digital dashboard where you can build a graphic interface for your project by simply dragging and dropping widgets.

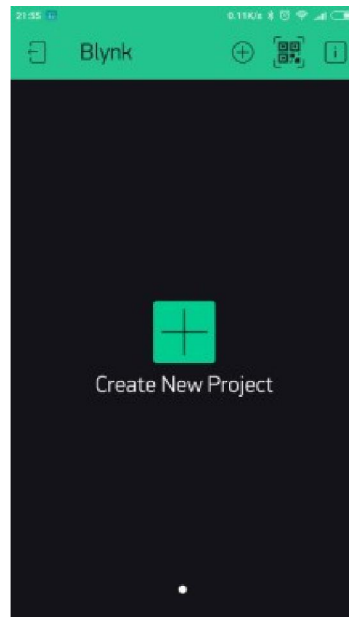

**Fig. Blynk Application**

The prototype is constructed as follows: Taking a plastic container or a dustbin, placing an ultrasonic sensor at the front part of the dustbin. The lid of the dustbin is taken as a card board and a servo motor is placed on the lid. Another ultrasonic sensor is placed inside the dustbin. The code of this project is divided into two parts. The first part code indicates the working of the dustbin

i.e. mainly opening the lid of the dustbin. The second part code indicates the notification part which is received on the mobile using the Blynkapp. The first part is constructed as follows: The ultrasonic sensor placed at the front part has four pins named Vcc, GND, ECHO and TRIG. The pin TRIG, pin ECHO is connected to digital pin numbers two and three on the Arduino Board. The servo motor has three pins named Vcc, GND, and servo pin. The servo pin of Servo motor is connected to digital pin number nine on the Arduino board. The Vcc of ultrasonic sensor is connected to 5V of Arduino board and the Vcc of servo motor is connected to 3.3V of Arduino board. The GND pins are connected to ground on the Arduino board. After the connections are made, the Arduino is connected to the system and using the Arduino IDE the code is dumped inside the Arduino. This ends the connection and code dump for the first part. The second part is constructed as follows: The ultrasonic sensor which is placed inside the dustbin also has the same four pins named Vcc, GND, ECHO and TRIG. In the Arduino IDE the board has to be changed from Arduino UNO to NodeMCU, if the board is not available in the list then we need to install the board from the Boards Manager. In this part the TRIG and ECHO pins of ultrasonic sensor is connected to digital pins D5 and D6 of NodeMCU. The Vcc is connected to Vin of NodeMCU and GND to ground of NodeMCU. This is the connection that is required and now the code should be dumped into NodeMCU. This ends the connection and code dump for the second part.

### 3.2 Output



#### IV. LITERATURE REVIEW

Ghorpade-Aher et al. [7] developed a system of two major components that are the waste bin and garbage collecting truck, on command when the bin is full; it acts like a robot. On the rim of the bin and at the base of the robot facing forward are ultrasonic sensors. As a microcontroller, a Raspberry Pi zero W was used, and waste level and weight were measured using sensors to verify that the waste bin did not overflow. The waste container follows a predetermined path to a specific location, where garbage collection trucks will empty its contents once it is full. A Smart Home dustbin with radio frequency identification (RFID) technology and a door opening mechanism is also envisaged [8]. It is positioned at a specific height above ground level, allowing for interaction between the trashcan and the home dustbin via RFID. When the waste reaches its maximum level, an ultrasonic sensor will alert you. When the moving trash (Binbot) is interfaced with, the door opening mechanism is activated, and the waste is disposed of. The Internet of Things IoT is implanted in the moving trashcan using ultrasonic sensor, infrared sensor, and RFID transmitter. The flying rubbish follows a predetermined path owing to a line following mechanism [9, 10].

A flame sensor, raspberry pi, ultrasonic sensor, load cell, humidity sensor, GSM module, Wi-Fi, and LCD were used to develop integrated garbage level monitoring system for the trashcan [11]. With the use of sensors and wireless communication capabilities, the suggested system ensures real-time monitoring of trash levels, hence boosting the waste management system's efficiency. Another technique presented by Tambekar et al. [12], is to utilise sensors and a GSM module to monitor garbage collection and disposal inefficiencies and anomalies. Ultrasonic sensors were installed at various fill levels in the bin, allowing the device to operate continuously even in harsh conditions. A text message was sent to the waste management authorities using the GSM module.

In Manikandan et al. [13], the proposed system form by using an IR sensor, rain sensor, gas sensor, and microcontroller. The bin interfaced with Microcontroller PIC16F877A based IR sensor, rain sensor, gas sensor. The IR sensor indicates the level of waste in the bin; the rain sensor is an electrical conductor when the water drops on the sensor. It passes current, and it senses. Then the lid will automatically close. The gas sensor detects foul gas and relates to the microcontroller. When the waste level reaches the pre-set value, the signal will be sent to the waste truck drivers for prompt action to be taken. Bhatt et al. [14] developed a useful model of an automatic dustbin for the eradication of overflow waste bin. This model was made using Arduino microcontroller integrated with an IR sensor and servo motor for the opening of the bin lid and ultrasonic sensors for detecting waste level by measuring distance based on the time taken between the transmission and the reception phase. Also, ESP8266 a Wi-Fi module that is completely loaded with the TCP/IP stack, thus allows the micro-controller to link to numerous Wi-Fi networks. It is capable of both hosting an offloading application from any microprocessor. However, fire outbreak and rainfall were not considered in the development of the model.

#### Algorithm Used:-

```
#define BLYNK_TEMPLATE_ID "TMPL4yDpPzsU" #define BLYNK_DEVICE_NAME "Smart Dustbin" #define
BLYNK_FIRMWARE_VERSION "0.1.0"
#define BLYNK_PRINT Serial #include "BlynkEdgent.h" #define echoPin 32
#define trigPin 33 #include<Servo.h> Servo servo;
long duration; int distance;
int binLevel=0; void sendSensor()
{
int ir=digitalRead(34); if(ir==LOW)
{
servo.write(90);
for(int i=0; i<50; i++) // Delay for 5 Second
{
Blynk.virtualWrite(V2, 90); ultrasonic();
delay(100);
}
servo.write(0); Blynk.virtualWrite(V2, 0);
```

```
}  
if(ir==HIGH)  
{  
ultrasonic(); delay(200);  
}  
}  
void ultrasonic()  
{  
digitalWrite(trigPin, LOW); delayMicroseconds(2); digitalWrite(trigPin, HIGH); delayMicroseconds(10);  
digitalWrite(trigPin, LOW); duration = pulseIn(echoPin, HIGH);  
distance = duration * 0.034 / 2; //formula to calculate the distance for ultrasonic sensor binLevel=map(distance, 21, 0,  
0,100); // ADJUST BIN HEIGHT HERE Blynk.virtualWrite(V0, distance);  
Blynk.virtualWrite(V1, binLevel);  
}  
void setup()  
{  
Serial.begin(9600); servo.attach(13); pinMode(34, INPUT); pinMode(trigPin, OUTPUT); pinMode(echoPin, INPUT);  
BlynkEdgent.begin(); delay(2000);  
timer.setInterval(1000L, sendSensor);  
}  
void loop()  
{  
BlynkEdgent.run();  
timer.run(); // Initiates SimpleTimer  
}  
}
```

## V. CONCLUSION

IOT based Dustbins help the people to manage the waste easily and help them reduce the work of calling or waiting for the specific person to make the area clean and makes a healthier environment to live. They won't be any kind of diseases and the people will be fit and are not prone to diseases caused by these waste materials. The mission Swachh Bharat can also be implemented easily. This system assures the cleaning of dustbins soon when the garbage level reaches its maximum. It will take power supply with the help of Battery. If the dustbin is not cleaned in specific time, then the record is sent to the Sweeper or higher authority who can take appropriate action against the concerned contractor. It ultimately helps in keeping the surrounding clean and the waste management can be much easier.

## REFERENCES

- [1]. Rajapandian, B., Madhanamohan, K., Tamilselvi, T., Prithiga, R. (2019). Smart dustbin. International Journal of Engineering and Advanced Technology (IJEAT), 8(6): 4790-4795. <https://doi.org/10.35940/ijeat.F9359.088619>
- [2]. Omar, M.F., Termizi, A.A.A., Zainal, D., Wahap, N.A., Ismail, N.M., Ahmad, N. (2016). Implementation of spatial smart waste management system in Malaysia. In IOP Conference Series: Earth and Environmental Science, 37: 012059. <https://doi.org/10.1088/1755-1315/37/1/012059>
- [3]. Gayanthika, W.A.L., Maduranga, G.K.C.D., Silva, A.I.S., Wikramaratne, S.D.H.S., Ranasinghe, R.M.I.S. (2019). Smart dustbin for waste management. International Journal of Environmental Science and Development, 10(4): 118-121. <https://doi.org/10.18178/ijesd.2019.10.4.1159>
- [4]. Radhika, V., Rukkumani, V., Devasena, D., Ramya, R. (2019). Smart waste management system using IoT. International Journal of Research in Arts and Science, 5: 65-72. <https://doi.org/10.9756/bp2019.1001/08>



- [5]. Muyunda, N., Ibrahim, M. (2017). Arduino-based smart garbage monitoring system: Analysis requirement and implementation. 2017 International Conference on Computer and Drone Applications (IConDA), Kuching, Malaysia, pp. 28-32. <https://doi.org/10.1109/ICONDA.2017.8270394>
- [6]. Jajoo, P., Mishra, A., Mehta, S., Solvande, V. (2018). Smart garbage management system. 2018 International Conference on Smart City and Emerging Technology (ICSCET), Mumbai, India, pp. 1-6. <https://doi.org/10.1109/ICSCET.2018.8537390>
- [7]. Ghorpade-Aher, J., Wadkar, A., Kamble, J., Bagade, U., Pagare, V. (2018). Smart dustbin: An efficient garbage management approach for a healthy society. In 2018 International Conference on Information, Communication, Engineering and Technology (ICICET), Pune, India, pp. 1 -4. <https://doi.org/10.1109/ICICET.2018.8533851>
- [8]. Sanukrishna, S.S., Prakash, M.J. (2018). Thermal and rheological characteristics of refrigerant compressor oil with alumina nanoparticles-an experimental investigation. Powder Technology, 339: 119-129. <https://doi.org/10.1016/j.powtec.2018.08.003>
- [9]. Masane, G.V., Naphade, R.A. (2017). Smart garbage monitoring system: Present and future. Int. J. Trend Sci.Res. Dev. (IJTSRD), 1(6): 26-31.
- [10]. Olorunsola, A.B., Ikumapayi, O.M., Oladapo, B.I., Alimi, A.O., Adeoye, A.O.M. (2021). Temporal variation of exposure from radio-frequency electromagnetic fields around mobile communication base stations. Scientific African, 12: e00724. <https://doi.org/10.1016/j.sciaf.201.e00724>
- [11]. Tambekar, A., Channe, V., Raut, A., Chahodkar, A., Bhoskar, A., Thool, A. (2018). Innovation waste collection system using wireless sensor network AKA 'Smart Dustbin'. Innovation, 5(2): 1979-1980.
- [12]. Manikandan, R., Jamunadevi, S., Ajeyanthi, A., Divya, M., Keerthana, D. (2019). An analysis of garbage mechanism for smart cities. Int. Res. J. Eng. Technol, 6: 1709-1713.
- [13]. Bhatt, M.C., Sharma, D., Chauhan, A. (2019). Smart dustbin for efficient waste management. International Research Journal of Engineering and Technology, 6(7): 967-969.
- [14]. Alsayaydeh, J., Wong, A., Khang, Y., Indra, W.A., Shkaruplyo, V. (2019). Development of smart dustbin by using apps. Journal of Engineering and Applied Sciences, 14(21): 3703-3711.
- [15]. Raaju, V.A., Meeran, J.M., Sasidharan, M., Premkumar, K. (2019). IOT based smart garbage monitoring system using ZigBee. 2019 IEEE International Conference on System, Computation, Automation and Networking (ICSCAN), Pondicherry, India, pp. 1 -7. <https://doi.org/10.1109/ICSCAN.2019.8878742>
- [16]. Prakash, S., Jayalakshmi, V. (2018). An efficient smart garbage dustbin monitoring system enhanced with wi-fi technology. International Journal of Pure and Applied Mathematics, 119(12): 6789-6795.