

Raspberry PI Vehicle Anti-Theft Face Recognition System

**Dr. V. S. Ubale, Dongare Nikita Sharad, Wale Priyanka Vasant,
Pawbake Priyanka Santosh, Bodke Kaveri Keshav**

Department of Electronics Engineering
Amrutvahini College of Engineering, Sangamner, India

***Abstract:** This is an advanced system that can be utilized in many cars. Today, it is not difficult to make duplicates of vehicle keys and using such keys increases the risk of robbery. For such problems, we hereby propose an efficient and reliable solution. Our system uses a face recognition system to identify the authorized users of the vehicles and only authorized users are allowed to use the vehicle. This allows for a fast easy to use the authentication system. The system uses a Raspberry Pi circuit, it also consists of a camera. When we turn on the system authority provided by 3 options that are registration, start, and clear data, while registering, it first scans the owner's face. After successful registration, the owner can start the vehicle. If an unauthorized user tries to use the car, the system scans the person's face and checks whether face matches with the authorized face, if it does not match the system denies. In this way, the system helps to secure such intelligent vehicles.*

Keywords: Face recognition system(FRS), Raspberry Pi, message services, Global System for Mobile

I. INTRODUCTION

This is an advanced system which can be utilized in many cars. Today, it is not difficult to make duplicates of vehicle keys and using such keys increases the risk of robbery. For such problem, we have come up with a solution. Our system uses face recognition system to identify the authorized users of the vehicles and only the authorized users are allowed to use the vehicle. System uses raspberry pi circuit, it consists of 24 x 4 LCD display, a motor & a buzzer alarm, it also consists of a camera. When we turn on the system authority provided by 3 options that is registration, start and clear data, while registering, it first scans the owner's face. After successful registration, the owner can start the vehicle. To stop the vehicle, the owner needs to press the back command. If an unauthorized user tries to use the car, the system scans the person's face, and checks whether face matches with the authorized face, if it does not match the system denies and the buzzer starts. In this way system helps to secure such intelligent vehicles.

With the new modern era development of new technologies is a must be it in the management sector or in the technical sector. improvements are necessary for every field. regarding the project chosen in the field of vehicle security. various techniques have been improved such as biometrics, retinal scanning, image processing. controlled by programmed Raspberry Pi.

II. BLOCK DIAGRAM

Figure.1 shows the block diagram representation of the vehicle security system The central processing unit here is the Raspberry Pi system .it controls the GSM module, camera, and operations related to the database. When an unauthorized image is detected by the programmed algorithm, the controller takes the information in the hold and stops the working of a motor which then informs the authorized user by sending messages through the GSM module.

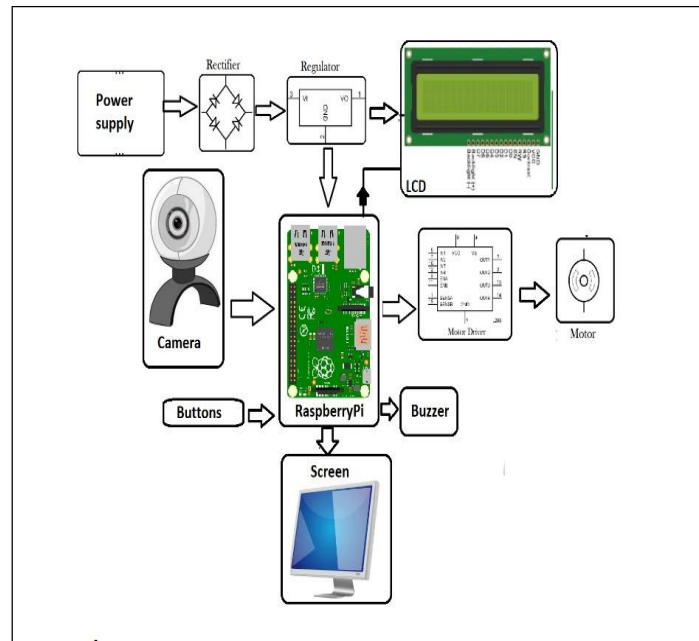

Fig- 1: Structural Outline

III. EXISTING SYSTEM

In the existing system of car securities, various sensors are used door sensors, engine sensors, light sensors, etc.

Where the door sensors are used for locking and unlocking the car doors through suitable key, when any duplicate key is inserted it sends some signals to the controller, however when key is made suitable as the original one the sensor might not be able to differentiate the changes in the system hence resulting in the car theft. The other method to limit this theft is a surveillance pad that is used to monitor the car which consists of RF receiver, processing unit alarm, and display, but the drawback here is this surveillance pad should be carried by the user everywhere. The engine and door sensors here are not that reliable.

In the existing system, the car uses an alarm system where the car makes a sound as soon as a person enters it but once it's lost there is no assurance that we can get it back, the alarm sometimes gets unnoticed which is the major drawback of the alarm system.

IV. FACE RECOGNITION ALGORITHM:

It is a software application that is used for facial recognition that automatically identifies or verifies a person using facial features available in the database. The facial recognition algorithm works by comparing new facial features from the image taken and facial images that are already uploaded in the database. The face recognition is the most popular area of research techniques in image processing and computer vision, and one of the widely used successful applications of image detection.

The face recognition algorithm is programmed in such a way, such that it identifies the faces by retrieving facial data from the digital image of a person.

For example, the algorithm may detect or verify the relative position, the shape of eyes, cheekbones, nose, ears, and size. These features are then compared with the available data.

The earlier system used simple geometric models, but in this era, the face recognition process has evolved into sophisticated representations and identifying processes. FRS is in high demand in the commercial market and has received great attention in the research field of biometrics and computer vision. FRS uses still images for recognition.

GSM MODULE:

The GSM module demonstrates the use of AT commands. They can feature all the functionalities of a mobile phone through the computer like making and receiving calls, SMS, MMS, etc. These are mainly employed for computer-based SMS and MMS services.

RASPBERRY PI:

The Raspberry Pi is a credit card-sized mini computer that can be used for many small computing tasks and IoT(Internet of Things). It is based on ARM architecture and uses fanless CPU and has all the ports which you'll need for a computer to be connected to such as an ethernet cable, HDMI, audio jack, USB, etc.

The basic use of Raspberry Pi is for educational purpose, it is being used by hardware enthusiasts, teachers, hobbyists, students, professors, etc and also by high school students for their projects related to computer science.

Raspberry Pi 3 uses or it can be used to upgrade a Linux based Debian operating system or Fedora-based ARM operating system or there is a Ubuntu-based Linux ARM- based operating system too. Everything here is used for educational purposes.

HAAR CASCADE:

For face recognition Haar cascade methodology is used. It is a machine learning based approach where a cascade function is trained from a lot of positive and negative images. It is then used to detect objects in other images. Initially, positive and negative image is taken in consideration to train classifier. Every value of the feature is obtained by subtracting the sum of pixels under white rectangle from the sum of pixels under black rectangle. Now all possible sizes and locations of each kernel is used to calculate plenty of features. For feature calculations we will find sum of pixels under white and black pixels. Among all the features we have calculated, most of them are irrelevant. For example if we consider the image we have put in our project, the first feature selected seems to focus on the eyes more than the nose and cheeks. Second one is made dark for the eyes and the bridge of the nose is focused.

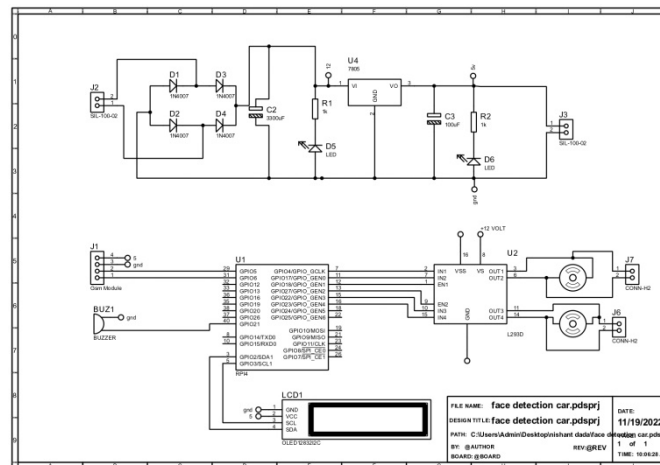

Fig- 2: Circuit Diagram

For getting better values while doing the thresholding of image and histogram of image, it is important to get grayscale of the original image. As there are chances to get less accuracy or error while thresholding and taking results using histogram grayscale image is more helpful.

By considering the threshold effect for classifying the face to positive and negative. We have selected the minimum rate feature for getting best classifies the face and non-face images. The process is continued for getting the required accuracy and minimum error rate. Hence the threshold image we have got is as shown.

V. APPLICATIONS

- Automobile Security.
- Access Control.

- Immigration.
- Education.
- Retail.
- Healthcare.

VI. ADVANTAGES

If an unauthorized user tries to use the car with efficient security, the system scans the person's face, and checks whether face matches with the authorized face, if it does not match the system denies and the buzzer starts. In this way system helps to secure such intelligent vehicles.

VII. DISADVANTAGES

- Threatens privacy.
- Imposes on personal freedom.
- Violates personal rights.
- Data vulnerabilities.
- Misuse causing fraud and other crimes.
- Technology is still new.
- Errors can implicate innocent people.
- Technology can be manipulated.

VIII. METHODOLOGY

Today, it is not difficult to make duplicates of vehicle keys and using such keys increases the risk of robbery.

Solution:

1. The system uses a face recognition system to identify the authorized users of the vehicles.
2. The authorized users are allowed to use the vehicle.
3. When we turn on the system authority provided by 3 options that are registration, start, and clear data.
4. While registering, it first scans the owner's face. After successful registration, the owner can start the vehicle.

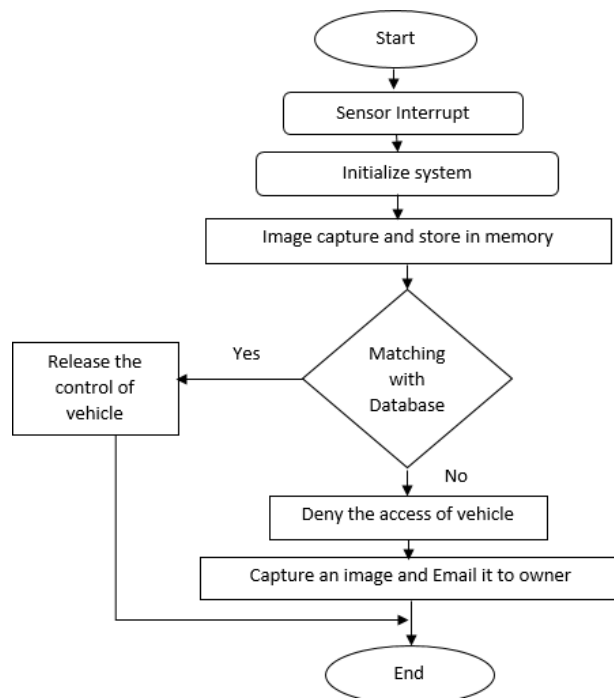

Fig- 6: Flowchart

SYSTEM DESIGN:

- Raspberry Pi 3
- Relay
- Camera
- Cables and Connectors
- DC Fan
- GSM

SOFTWARE REQUIREMENTS

- Python
- OS: Linux

As explained our system consists of Raspberry pi as the central processing unit that receives the data using a camera. This hidden camera captures the facial data and sends it to the processing unit for comparison. We maintain a database that contains the facial data as given by the user and cannot be manipulated by any other unauthorized user. Our system also has a GSM module that helps the CPU to generate SMS to the owner of the car when unauthorized access is noticed.

Then CPU generates command that switches off the motor. This restricts unauthorized users to take access to the vehicle. The algorithm is programmed in Raspberry pi which helps us to compare camera captured images with database information, it also generates commands to operate other devices/components or other add-ons as defined by the programmer.

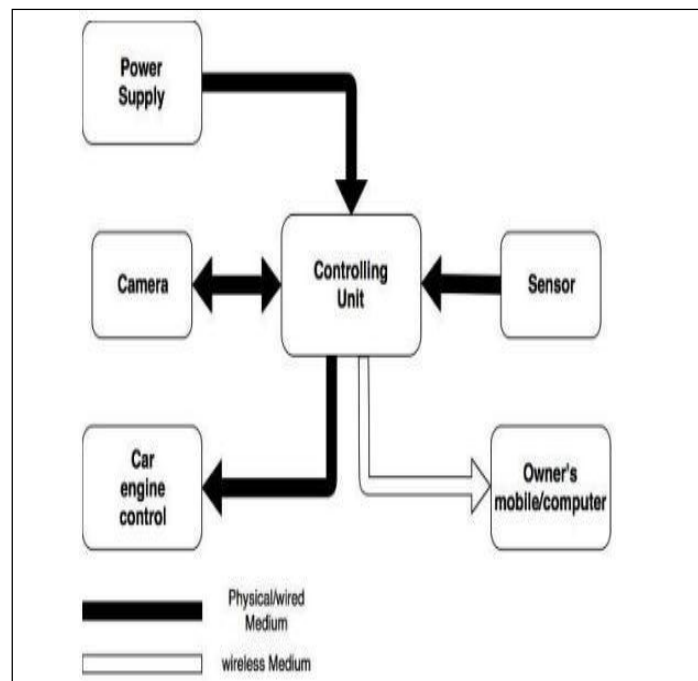

Fig- 6: Block diagram

IX. RESULT

Accuracy of our project is 95%. Quick response as soon as image is captured by the camera it will respond within 2 Sec.

X. CONCLUSION

By using this particular system we can increase and maintain the safety of the vehicle by providing special programmed functions to it. If any unauthorized user tries to use or steal the car the central controller will stop its working immediately and appropriate SMS will be sent to the authorized user through a GSM module.

REFERENCES

- [1]. Sukanya Sagarika Meher; Pallavi Maben “Face recognition and facial expression identification using PCA”, 2014 IEEE International Advance Computing Conference (IACC).
- [2]. S. Padmapriya ; Esther Annlin Kala James “Real time smart car lock security system using face detection and recognition”, 2012 International Conference on Computer Communication and Informatics.
- [3]. Ketan J. Bhojane, S.S.Thorat; “Face Recognition Based Car Ignition and Security System”; International Research Journal of Engineering and Technology (IRJET), Vol 05, May 2018, pp. 2395-0072.
- [4]. Hanna Pasula, Stuart Russell, Michael Ostland, and Ya’acov Ritov, “Tracking many objects with many sensors”, Proceedings of the Sixteenth International Joint Conference on Artificial Intelligence, IJCAI 99, Stockholm, Sweden, July 31 – August 6, 1999.
- [5]. Kuan-Wen Chen; Chih-Chuan Lai; Yi-Ping Hung; Chu-Song Chen, "An adaptive learning method for target tracking across multiple cameras," Computer Vision and Pattern Recognition, 2008. CVPR 2008. IEEE Conference on, vol., no., pp.1-8, 23-28 June 2008.
- [6]. Campbell, R.; Krumm, J., "Object recognition for an intelligent room," Computer Vision and Pattern Recognition, 2000. Proceedings. IEEE Conference on, vol.1, no., pp.691-697 vol.1, 2000.
- [7]. Dan Xie; Tingxin Yan; Ganesan, D.; Hanson, A., "Design and Implementation of a Dual-Camera Wireless Sensor Network for Object Retrieval," Information Processing in Sensor Networks, 2008. IPSN '08. International Conference on, vol., no., pp.469-480, 22-24 April 2008.
- [8]. R. Cucchiara, C. Grana, A. Prati, and R. Vezzani, “Computer vision system for in-house video surveillance”, IEE Proceedings-Vision, Image, and Signal Processing, 2005, pp. 242 – 249.
- [9]. Zhao, Yanbo, and Zhaohui Ye, “A low cost GSM/GPRS based wireless home security system”, IEEE Transactions on Consumer Electronics 54, no. 2 (2008).
- [10]. Rakesh, V. S., P. R. Sreesh, and Sudhish N. George, “An improved real-time surveillance system for home security system using BeagleBoard SBC, Zigbee and FTP webserver,” IEEE Int.Con, 2012, pp.1240-1244.