

Smart Street Light using IoT

Sridevi Mali Patil, GS Benaka Tejasvi Patil, Raja H, Sanjana YM, Udeda Abhishek

Department of Computer Science and Engineering

Rao Bahadur Y Mahabaleswarappa Engineering College, Bellary, Karnataka, India

Abstract: *The main consideration in the present field technologies are Automation, Power consumption and cost effectiveness. Automation is intended to reduce man power with the help of intelligent systems. Power saving is the main consideration forever as the source of the power are getting diminished due to various reasons. As we all know that energy consumption has been increasing day by day so, to overcome these consequences we are using IoT devices. This project proposes a modal for modifying street light illumination by using sensors at minimum electrical energy consumption. When presence is detected, all surrounding street lights glow at their brightest mode, else they stay in the dim mode. LED bulbs shall be implemented as they are better than conventional incandescent bulbs in every way. This shall reduce heat emissions, power consumption, maintenance and replacement costs and carbon dioxide emissions. Coupled with SSSLS (Solar Smart Street Light System), massive energy-savings are envisioned. Also, a demonstration with a real-time proto type model involving costs and implementation procedure has been developed using internet of things to visualize the real time updates of street processing and notifying the changes occur.*

Keywords: SSSLS.

I. INTRODUCTION

The street lighting is one of the largest energy expenses for a city. An intelligent street lighting system can cut municipal street lighting costs as much as 50% - 70%. The present system is like the lights will be switched on in the evening before the sun sets and they are switched off the next day morning after there is sufficient light on the outside[1]. But the actual timing for these lights to be switched on are when there is absolute darkness. With this, the power will be wasted up to some extent. In sunny and rainy days, ON and OFF time differ discernibly which is one of the significant hindrances of the present street lights systems. Also the manual operation of the lighting system is completely eliminated. The energy consumption in entire world is increasing at the fastest rates due to population growth and economic development and the availability of energy sources remains woefully constrained. Resource augmentation and growth in energy supply has not kept pace with increasing demand and, therefore, continues to face serious energy shortages. Streetlights are an integral part of any developing locality. They are present on all major roadways and in the suburbs too. Every day, streetlights are powered from sunset to sunrise at full strength, even when there is no one around. On a global scale, millions of dollars are spent each day on these street lights to provide the required electrical energy. The maintenance and replacement costs of conventional incandescent bulbs are immense. They consume a lot of electric power to function and their heat emissions are also quite high. All of this contributes to greater demand of electricity production and consequently, more carbon dioxide emissions from powerhouses. So, along with unnecessary light pollution, this practice causes damage to our planet too. The main aim of the project is to provide an "IoT based Automatic Street Lightning System" powered with solar energy during night time. We use the word "smart" because the system not only provide power to the street lights but also helps in detecting the direction of movement of the pedestrian and helps him by means of illuminating the path of movement till the near next street light. By integrating the entire street lights with Smart street light system it is possible to systematically help the pedestrian to reach the destination in the remote rural areas which are facing serious electric power supply problem. The same system can also be used in metropolitan cities as well. A simple and effective solution to this would be dimming the lights during off peak hours. Whenever presence is detected, the lights around it will glow at the normal (bright) mode. This would save a lot of energy and also reduce cost of operation of the streetlights. We can check the status of street light on internet using IOT (Internet of things) from anywhere in real time and solve the issues if happen during the processing.

II. RELATED WORKS

S.Suganya et al have proposed about Street Light Glow on detecting vehicle movement using sensor isa system that utilizes the latest technology for sources of light as LED lamps. It is also used to control the switching of street light automatically according to the light intensity to develop flow based dynamic control statistics using infrared detection technology and maintain wireless communication among lamppost and control terminal using ZigBee Wireless protocol. It also combines various technologies: a timer, a statistics of traffic flow magnitude, photodiodes, LED, power transistors.

K.Santha et al have surveyed on Street Lighting System Based on Vehicle Movements. The system operates in the automatic mode which regulates the streetlight according to brightness and dimness algorithm and light intensity. The control can be made according to the seasonal variation. It includes a time cut-out function and an automatic control pattern for conserving more electricity. The whole project was implemented using a PIC microcontroller.

Proposed a ZigBee based Remote Control Automatic Street Light System. The system isdesigned with the help of ZigBee modules that helps in detecting the faulty lights and control the light. It also discusses about an intelligent system that takes automatic decisions for ON/OFF/DIMMING considering the vehicle movement or pedestrian and also the surrounding environment. PIR motion sensor is used to detect movement of both living and non-living things.

M.Abhishek et al have implemented design of traffic flow based street light control system with effective utilization of solar energy in the year 2015. They used the renewable source of energy i.e. the solar power for street lighting. They have also used 8052 series microcontroller and is developed by replacing the normal bulbs with the LEDs due to which the power consumption is reduced by 3 times. Sensors are placed on either side of the road which senses the vehicle movement and sends the commands to the microcontroller to switch ON and OFF the lights. Here all the street lights remain switched off and it glows only when it senses the vehicle movement. Hence, because of the microcontroller, even when its night the lights are switched off.

C.Bhuvaneshwari et al have analysed the street light with auto tracking system by which one can increase the conversion efficiency of the solar power generation. Here, the sun tracking sensor is the sensing device which senses the position of the sun time to time and gives the output to the amplifier based on light density of the sun. Sun tracking sensor is LDR, amplifier unit is used to amplify the LDR signals which converts low level signals to high level signals and the output is given to comparator. The LM324 IC is used as an amplifier. Comparator compares the signals and gives the command to AT89C51 microcontroller.

III. PROBLEM STATEMENTS

Statement 1: Street lights are on in the presence of sun light.

Statement 2: Street lights are on in the absence of any vehicle and pedestrian.

Disadvantages of Classical Street Light:

- Street lights remain always on when there is presence of light.
- These street lights need a manual switching operation.
- It also needs man power.
- These street lights are unnecessarily glowing with its full intensity in the absence of any activities in the street.
- High power consumption and waste of energy.

Advantages of the Proposed System:

- Automatic Switching of Street lights.
- Maintenance Cost Reduction.
- Reduction in CO₂ emission.
- Reduction of light pollution.
- Energy Saving.
- Reduction of manpower.

IV. OBJECTIVE

The main objective of this project is to implement an IoT based Automatic Street Lightning System. As the traffic decreases slowly during late-night hours, the intensity gets reduced progressively till morning to save energy and thus, the street lights switch on at the dusk and then switch off at the dawn, automatically. The process repeats every day. White Light Emitting Diodes (LED) replaces conventional HID lamps in street lighting system to include dimming feature. The intensity is not possible to be controlled by the high intensity discharge (HID) lamp which is generally used in urban street lights. LED lights are the future of lighting because of their low energy consumption and long life. LED lights are fast replacing conventional lights because intensity control is possible by the pulse width modulation. This proposed system uses an Arduino board. Strings of LED are interfaced to the Arduino board. A programmed Arduino board is engaged to provide different intensities at different times of the night. This project is enhanced by integrating the LDR to follow the switching operation precisely and IOT to display the status of street on web browser and help in controlling it.

The main objectives are as follows:

- To avoid unnecessary Waste of light.
- Provide efficient, automatic and smart lighting system.
- Totally based on Renewable energy sources.
- Longer life expectancy.
- Energy Saving.

V. PROPOSED METHOD

The present system employs power delivery via a single phase line to the streetlight. The proposed system involves five more components to regulate the power delivery. [7] An Infra -Red Proximity Sensor at the base of the street light detects presence in a small area around the street light. The data from the sensor is sent to the Arduino which forms brain of the circuit. The Arduino then commands to switch between dim and bright modes depending upon the requirement and thus controls the brightness of the street light. A battery eliminator, also powered by the single phase line, is used to supply 5V inputs to the sensors and Arduino.

- **Arduino IDE:** The Arduino Software (IDE) is an open source software and it makes easy to the code and upload it to the board. It runs on the different platform from Windows, MAC OS, Linux. The environment is written in Java and before running the IDE Java software to be installed on the machine this software can be used with any Arduino board.
- **LDR:** A Light Dependent Resistor (LDR) or a photo resistor is a device whose resistivity is a function of the incident electromagnetic radiation. Hence, they are light sensitive devices. They are also called as photo conductors, photo conductive cells or simply photocells. They are made up of semiconductor materials having high resistance. A light dependent resistor works on the principle of photo conductivity.
- **IR Sensor:** An infrared sensor is an electronic instrument that is used to sense certain characteristics of its surroundings by either emitting and/or detecting infrared radiation. It is also capable of measuring heat of an object and detecting motion. Infrared waves are not visible to the human eye.

The design basically includes three working modes:-

- **OFF mode:** When there is enough natural light in the surrounding i.e. during the daytime, the entire system is switched off and the batteries are charging.
- **Active mode:** When the natural light drops below a certain level the system automatically turns on and the motion sensors are powered.
- **ON mode:** On the presence of pedestrians, the sensors turn on which in turn switches on the LED lights. These lights turn off after a period of time.

5.1 PERT CHART

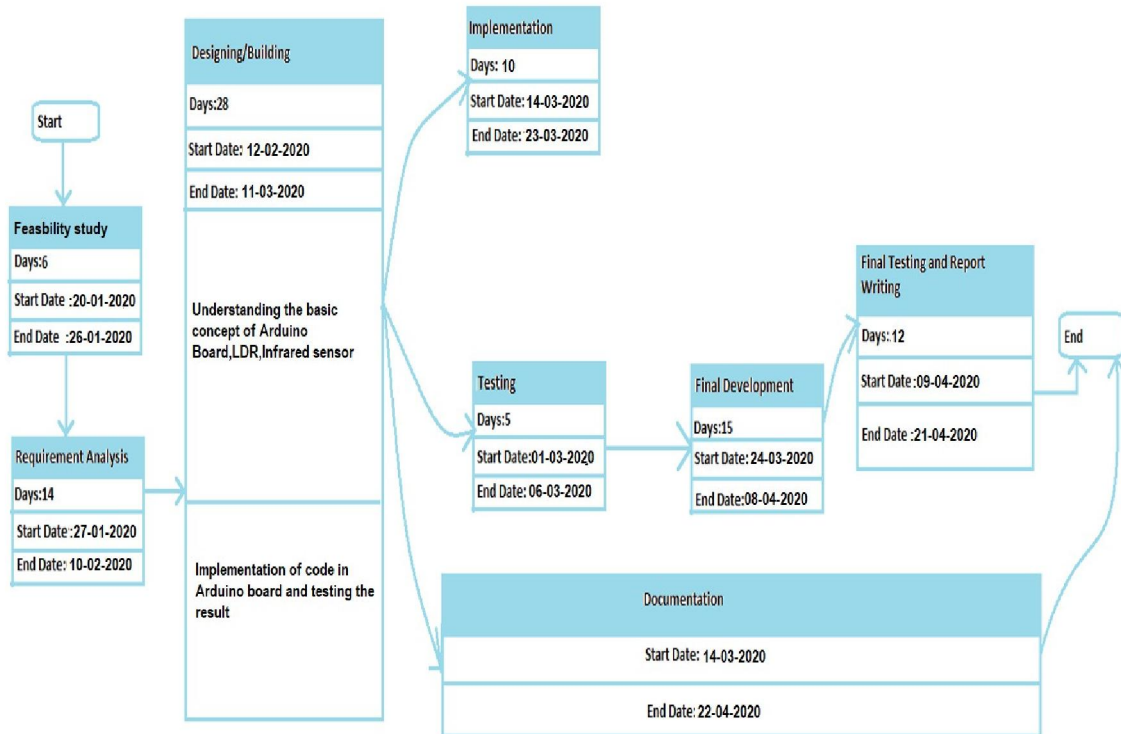

Flow chart of Smart lighting system:

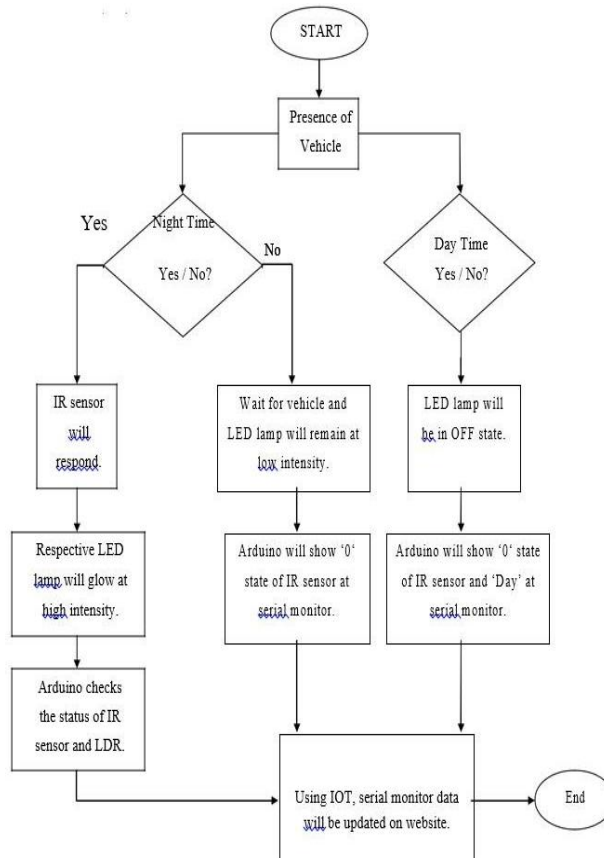

VI. IMPLEMENTATION

OVERVIEW:

- We have used one LDR circuit to distinguish between the day and night. LDR with a small resistor in series is connected across the 5V and GND of the Arduino Uno and from the midpoint of the LDR potential divider circuit the output of the circuit is feed to A0 of the Arduino which turn on all the street lights which are represented by Led connected to the output pin (ie: 5 ,6 ,7 ,8,9 ,IO ,71,,12, 13).
- LDR is a special type of resistor whose value depends on the brightness of the light which is falling on it. It has resistance of about 1M-ohm when in total darkness but a resistance of only 5 k-ohm when brightness is illuminated.
- Four infrared receiver and sender circuits are made to detect the movements and output from the receiver is fed to the input terminal (ie. 1,2,3,4)which corresponds to the led connected to 5,6,7,8,9,L0,LI,L2,L3 respectively. All the object sensors are connected between 5V and GND of the Arduino UNO.

WORKING OF THE CIRCUIT:

- The output from the LDR is connected to the A0 and initially LDR flag and LDR value is set to zero. The value of LDR reference value is initialized and set to 500(baud rate). If the Arduino UNO reads any value from LDR whose value is less than the LDR reference value than it will turn on the street lights.
- The output from IR1 and IR2, IR3, and object IR4 are connected to the pin A1,A2,A3,A4 and reference value of all sensor is set to 500(baud rate) which corresponds to led connected to ~3,~5,~6,~9,and~10.
- Another four proxy value for each object sensor are set to zero and if any object sensor detects any presence of objects then Arduino UNO compares the value with the object reference value. If the sensed value is less than the reference value it will glow with 100% of its intensity otherwise LEDs will be off.
- The first and the last LED glows continuously to detect the start and end of the road.

PIN DIAGRAM:-

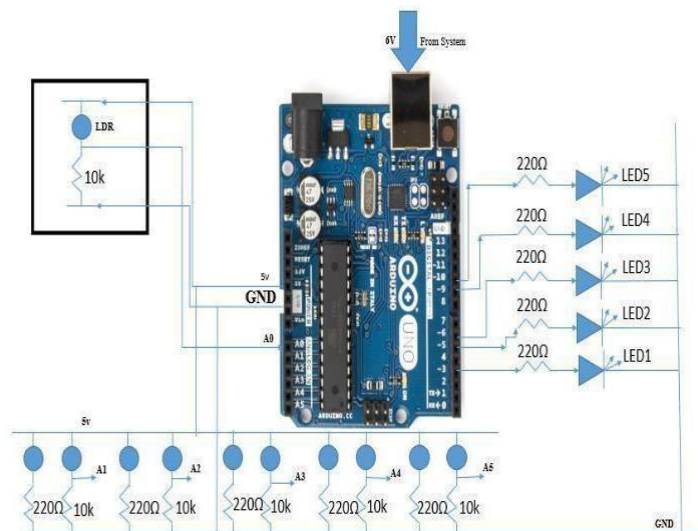

VII. RESULTS

The project aims were to reduce the side effects of the current lighting system and find a Solution to save power. In this project the first thing to do is to prepare the inputs and outputs of the system to control the lights. The project shown in the figure has been implemented and works as expected and will prove to be very useful. The prototype of the system with obstacle detection on the street through IR sensor where the IR Sensor detects the obstacle and switch ON the Lights.

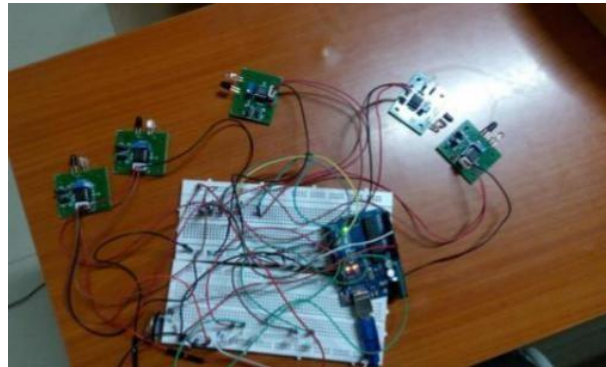

Fig: 6.1(Initial Setup Phase 1)

The Fig 6.1 depicts the initial setup of the hardware. All the components are in accordance to every other component. The five IR sensors are placed next to each other. The Arduino board is connected to the external power supply for the flow of current. All the five IR sensors are connected to the Arduino board. The resistor is placed on the bread board to control the flow of current.

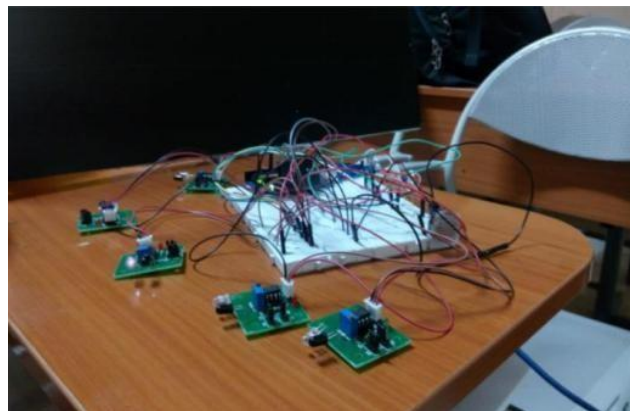

Fig: 6.2 (Initial Setup Phase 2)

The Fig 6.2 depicts the second phase where all the LED's glow immediately for few seconds and then switches off. It glows on as soon as it becomes dark. Except the first LED, all the other LEDs are switched off.

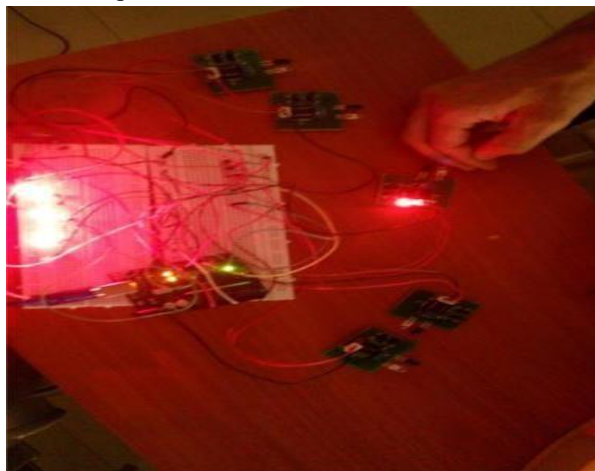

Fig: 6.3(Object detection)

The Fig 5.3 depicts the vehicle movement or object movement. As shown in the fig, the third streetlight is switched on as it detected the object. Immediately, as the vehicle passes by, these lights are switched off and the next block of lights are switched on.

VII. CONCLUSION AND FUTURE SCOPE

Using this smart project, we can also estimate the speed of the vehicle, recognizing the number plate, recognizing the accidents took place on roads etc.

This Smart Street light project not only helps in rural areas but also beneficial in urban areas too. As we are moving towards more advancement we require more power so use of renewable resources is useful and advantageous. With this project, we can even add smart parking of vehicle and it is even useful for driverless cars.

With the advances in technology and good resource planning the cost of the project can be cut down and also with the use of good equipment the maintenance can also be reduced in terms of periodic checks. The LEDs have long life, emit cool light, don't have any toxic material and can be used for fast switching. For these reasons our project presents far more advantages which can over shadow the present limitations. Keeping in view the long term benefits and the initial cost would never be a problem as the investment return time is very less. The project has scope in various other applications like for providing lighting in industries, campuses and parking lots of huge shopping malls. This can also be used for surveillance in corporate campuses and industries. This project "IoT Based Smart Intelligent Lighting System for Smart City" is a cost effective, practical, eco-friendly and the safest way to save energy and this system the light status information can be accessed from anytime and anywhere. It clearly tackles the two problems that world is facing today, saving of energy and also disposal of incandescent lamps, very efficiently

REFERENCES

- [1]. <http://opensourceecology.org/wiki/Automation>
- [2]. S.Suganya, R. Sinduja, T. Sowmiya & S. Senthilkumar, Street light glow on detecting vehicle movement using sensor
- [3]. K.SanthaSheela, S.Padmadevi, Survey on Street Lighting System Based On Vehicle Movements
- [4]. Srikanth M, Sudhakar K N, ZigBee Based Remote Control Automatic Street Light System
- [5]. M.Abhishek, Syed ajram shah, K.Chetan, K,Arun Kumar, Design and implementation of traffic flow based street light control system with effective utilization of solar energy, International journal of Science Engineering and Advance Technology, IJSEAT, Vol 3, Issue 9, September -2015
- [6]. C.Bhuvaneshwari, R.Rajeswari, C.Kalaiarasan, Analysis of Solar energy based street light with auto tracking system, International Journal of Advanced Research in Electrical, Electronics and Instrumentation Engineering, Vol 2, Issue 7, July 2013
- [7]. Steve Chadwick, "Street Light Monitoring – a Practical Solution magazine" November/December 2002
- [8]. "Intelligent Street Lighting System Using Gsm" International Journal of Engineering Science Invention ISSN (Online): 2319 – 6734,
- [9]. Archana. G, Aishwarya N, Anitha J "Intelligent Street Light System" International Journal of Recent Advances in Engineering & Technology, Vol-3, Issue-4, 2015.
- [10]. https://www.researchgate.net/publication/262352965_Smart_street_light_system_with_energy_saving_function_based_on_the_sensor_network
- [11]. <http://www.ee.ic.ac.uk/niccolo.lamanna12/yr2proj/report.pdf>