

33/11KV Substation Maharashtra State Electricity Distribution Co. Ltd. Lohara MIDC Yavatmal

Mr. Yash Raju Shendre, Mr. Shantanu Kishor Bayskar,
B.E. Electrical Engineering Third Year

Ms. Chinmayi Satish Thakare, Mr. Rupesh Rajabhau Borkhade
B.E. Electrical Engineering Final Year

Jawaharlal Darda Institute of Engineering and Technology, Yavatmal, Maharashtra, India
Shendreyash9@gmail.com, shantanubayskar@gmail.com, cthakare002019@gmail.com,
rupeshborkhade25@gmail.com

I. INTRODUCTION

Maharashtra State Electricity Distribution Company Limited (MSEDCL), a wholly owned corporate entity under the Maharashtra Government, was incorporated under the Companies Act on 31st May, 2005 after restructuring the erstwhile Maharashtra State Electricity Board to distribute electricity from the end point of transmission to the end consumers.

MSEDCL is a Public Company in the category of 'State Government Company' registered under the Companies Act 1956, with the main objectives of developing, operating and maintenance of distribution system for supplying electricity to the consumers in its area of supply. As a deemed distribution licensee under section 14 of the Electricity Act 2003, MSEDCL is carrying out the supply of power to the end users as well as maintaining the wire business for supply of such power.

Currently, MSEDCL provides electricity throughout the State of Maharashtra and in few suburbs of Mumbai city and is considered to be one of the largest power distribution Company both in the country and in Asia, in terms of number of consumers and electricity supplied whereby it serves more than 2.70 Crores consumers with around 70000+ employees. In terms of infrastructure, the Company operates a vast network comprising of 4000+ 33/11 kV sub-stations and switching stations, approximately 25,000 High Voltage Feeders, approximately 8 Lakh Distribution transformers, 3.30 Lakh KMs of 11 kV lines and approximately 50,000 KMs of 33 kV lines spread over 3.08 thousand sq.km geographical area of Maharashtra covering 41,928 villages and 457 towns. Presently, the Company operates through a network of offices consisting of a Corporate Office, 4 Regional Offices, 16 Zonal Offices, 46 Circle Offices, 147 Divisional Offices and 652 Sub-divisional offices.

The Company has generation tie up capacity of 33755 MW, of which 8027 MW is renewable energy. The Company is in surplus position since March 2012 and successfully met the peak demand of 22,832 MW in April 2021. The overall AT&C (Aggregate Technical and Commercial) losses for the Company has reduced from 33.89 % in FY 2006-07 to 20.73% FY 2020-21, which is below the national average of 23%. As a part of demand side management, agricultural feeders which are 40% of the total feeders, have been separated assuring minimum 8 hours of quality power supply to uplift the rural economy. Under the Chief Minister Solar Agricultural Scheme (akin to Central Government's KUSUM scheme), 106 feeders have been solarised, giving benefit of continuous supply to around 38,000 agricultural consumers. Under the same scheme, 1340 MW capacity has been contracted, out of which 339 MW has already been commissioned. The Company has entered into long- term PPAs (Power Purchase Agreements) to procure around 8000 MW of renewable energy.

33kV Switchyard

A 33 kV (kilovolt) substation switchyard is a crucial part of the electrical power distribution system. It plays a key role in transmitting and distributing power from the generating station to the end-users. The components of a typical 33 kV substation switchyard may include:

Incoming and Outgoing Lines:

- Incoming lines connect the substation to the highvoltage grid or generating station.

Transmission Stations:

-The power network features two key transmission stations, each designed to operate at distinct voltage levels.

The first is a 132 kV Substation situated at Darwha Rd.

The second is a 220 kV Substation located at Pandharkavda Rd.

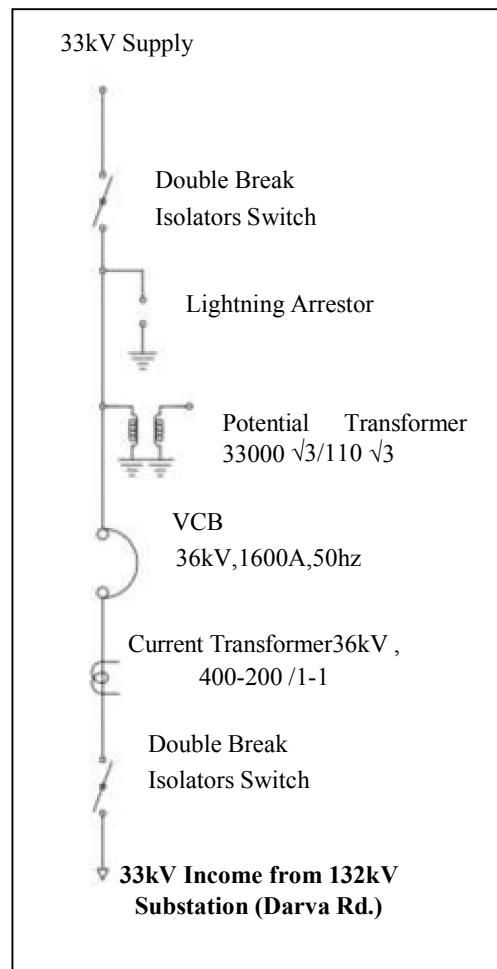

33kV Bus Structure

Feeder Structure:

- Both transmission stations are equipped with dedicated 33 kV feeders. These feeders serve as conduits for transporting electrical power from their respective transmission stations to the subsequent load centers or distribution systems.

Operational Status of Substations:

As of the current operational scenario, the Darwha Rd. Substation stands as the active hub, actively contributing to the supply of electrical power to the connected network.

On the other hand, the Pandharkavda Rd. Substation, though not currently engaged in active duty, assumes a standby position. This standby status implies its preparedness to seamlessly assume the power load in case the Darwha Rd. Substation encounters maintenance requirements or experiences a breakdown

Enhancing System Resilience:

- This dual-substation setup serves as a strategic component of the power distribution system, providing operational flexibility and a layer of redundancy.
- The standby mode adopted by the Pandharkavda Rd. Substation adds a crucial layer of resilience to the overall network. It serves as a failover option, guaranteeing a consistent and reliable power supply even when the primary Darwha Rd. Substation undergoes maintenance or experiences unexpected disruptions.
- Outgoing lines distribute power from the substation to the networks.

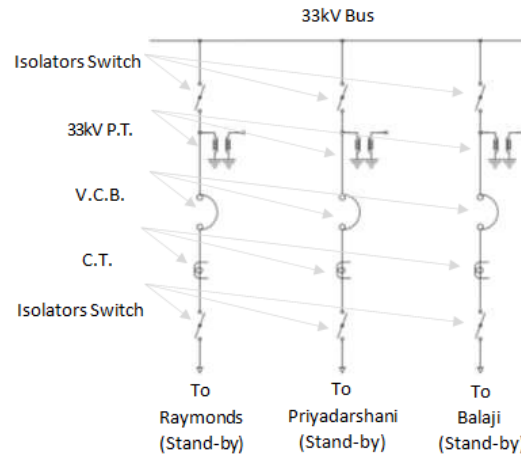

Substation Overview:

- The substation has three outgoing feeder lines, each carrying a voltage of 33 kilovolts (33kV).

Feeder Destination:

- The three feeder lines supply power to three different entities:
 - a. Raymond's: It is mentioned that this connection is on standby, indicating that it is not currently active, but the feeder lines are available for use.
 - b. Priyadarshani: This is another destination that receives power through one of the 33kV feeder lines.
 - c. Balaji: This is the third destination for power distribution. The company associated with Balaji is not currently consuming the supply, but it is mentioned that they will use the supply when their production starts.

Feeder Line Equipment:

- Each of the outgoing feeder lines is equipped with protective devices and equipment. These include:
 - a. Vacuum Circuit Breakers (VCB): VCBs are devices used to interrupt the flow of electric current in a circuit. They are commonly used for medium voltage applications like 33kV.
 - b. Current Transformers (CT): CTs are used to measure current in the feeder lines. They provide a reduced current proportional to the actual current flowing in the line for monitoring and protection purposes.
 - c. Potential Transformers (PT): PTs are used to measure voltage in the feeder lines. Similar to CTs, they provide a reduced voltage for monitoring and protection.
- Isolators: Isolators are devices that provide isolation and disconnection of the feeder lines. They are often used for maintenance or to isolate a section of the network.

Isolators (Disconnectors)

- Isolators are used for isolating a section of the switchyard or a particular equipment for maintenance purposes. They provide visible isolation and are operated only when the circuit is de-energized.



Double Break Isolators : Type - DB

Turn & twist mechanism with self wiping contacts. Fixed & moving blades are made out off hard drawn electrolytic copper. Simultaneous operation of three poles by individual/group with low operating torque. Type tested as per IS and IEC. Suitable for all typical substation layouts.

Circuit Breakers:

Circuit breakers are essential for interrupting the current flow in case of a fault or for maintenance purposes. They protect the system from overloads and short circuits.

33kV Vacuum Circuit Breaker [V.C.B.]

A breaker which used vacuum as an arc extinction medium is called a vacuum circuit breaker. In this circuit breaker, the fixed and moving contact is enclosed in a permanently sealed vacuum interrupter. The arc is extinct as the contacts are separated in high vacuum. It is mainly used for medium voltage ranging from 11 KV to 33 KV.

Vacuum circuit breaker has a high insulating medium for arc extinction as compared to the other circuit breaker. The pressure inside the vacuum interrupter is approximately 10^{-4} torr and at this pressure, very few molecules are present in the interrupter. The vacuum circuit breaker has mainly two phenomenal properties.

High insulating strength: In comparison to various other insulating media used in circuit breaker vacuum is a superior dielectric medium. It is better than all other media except air and SF₆, which are employed at high pressure



When an arc is opened by moving apart the contacts in a vacuum, an interruption occurs at the first current zero. With the arc interruption, their dielectric strength increases up to a rate of thousands times as compared to other breakers. The above two properties make the breakers more efficient, less bulky and cheaper in cost. Their service life is also much greater than any other circuit breaker, and almost no maintenance are required.

33kV V.C.B. Specification

-33 kV VCB Specification of the Incomer supply of the Substation

| | |
|-------------------------------------|---------------------|
| VOLTAGE | 36kV |
| CURRENT | 1600A |
| PREQUENCY | 50Hz |
| INSULATION LEVEL | 70kV/170kVP |
| SHORT CIRCUIT BREAKER CURRENT | 25kV |
| MAKING CAPACITY | 62.5kA (PEAK) |
| SHORT TIME CURRENT ITS DURATION | 25kA for 3SEC |
| OPERATION DUTY | 0-0.3 SEC.CO-3im-CO |
| AC SUPPLY VOLTAGE OF AUX CIRCUIT | 240V AC |
| CLOSING/TRIP COIL VOLTAGE | 30V DC |
| LIGHTING IMPULSE WITH STAND VOLTAGE | 170kV peak |
| OUT OF PHASE BREAKING | 6.3kA |
| WEIGHT | 800kg |

Current Transformers (CTs) and Voltage Transformers (VTs):

- CTs and VTs are used to measure current and voltage levels in the system. They provide input signalsto protection and metering devices.

Current Transformers (CTs)

-A Current Transformer (CT) is used to measure the current of another circuit. CTs are used worldwideto monitor high-voltage lines across national power grids. A CT is designed to produce an alternating current in its secondary winding that is proportional to the current that it is measuring in its primary. In doing so, the current transformer reduces a high current to a lower value and therefore provides a safe way of monitoring electrical current flowing in an AC transmission line.



33kV Current Transformer

-In an electrical power distribution system with a 33kV bus, each feeder and incomer supply is equipped with a Current Transformer (CT). This includes the three feeders connected to the three transformers. A Current Transformer is a device used to measure the current flowing through a conductor by producing a proportional current in its secondary winding, which can then be easily monitored or measured. This setup allows for accurate current measurement and monitoring of each feeder and incomer supply, ensuring proper management and control of the electrical system.

Current Transformer Rating:

| | |
|----------------------------|-----------------|
| HIGHEST SYSTEM VOLTAGE | 36kV |
| RATED PRIMARY CURRENT AMPS | 400-200/1-1 |
| S. T. CURRENT | 26.2kA for 1Sec |
| INSULATION LEVEL | 70kV |
| FREQUENCY | 50Hz |
| WEIGHT OF OIL | 27kg |
| TOTAL WEIGHT | 135kg |

There are two cores in the C.T. according to that the Ratio will be: -

| CORE | TERMINALS | RATIO AMPS | RATING | K.P.V./EX. AMPS |
|------|-----------|------------|--------|-----------------|
| 1. | 1S1-1S2 | 200/1 | - | 330 V |
| | 1S1-1S3 | 400/1 | - | 630 V |
| 2. | 2S1-2S2 | 200/1 | 30 | |
| | 2S1-2S3 | 400/1 | 30 | |

Voltage Transformers (VTs)

A voltage transformer, also known as a potential transformer, is an instrument transformer used in power systems for accurate voltage measurement and protection purposes. It is designed to have a negligible load on the circuit being measured and accurately transform higher voltages to lower voltages.

33kV substation busbar and multiple feeder lines:

Incomer Feeder Line with Potential Transformer:

The incoming feeder line, which brings power to the substation, typically has a Potential Transformer connected to it. The primary winding of the PT is connected across the high-voltage line (in this case, the 33kV line). The secondary winding of the PT produces a reduced voltage, usually 110V or 120V, which is a standard value for metering and relay applications.

Outgoing Feeder Lines with Potential Transformers:

Each outgoing 33kV feeder line leaving the substation also has its own Potential Transformer. Similar to the incomer PT, the primary winding of these outgoing feeder PTs is connected across the respective outgoing feeder lines. The secondary winding of each PT on the outgoing feeders also produces a reduced voltage (e.g., 110V or 120V).

Connection to Metering and Protection Devices:

The secondary voltage from each PT is connected to metering devices, such as voltage meters or energy meters, for monitoring and billing purposes. Additionally, the secondary voltage is connected to protective relays that continuously monitor the voltage levels and react to abnormal conditions.

Busbars:

- Busbars are conductors that connect various incoming and outgoing lines, isolators, and other equipment in the switchyard. They play a crucial role in facilitating the flow of electrical power.

-In a 33kV substation, the busbar is a metallic strip (usually copper or aluminum) that acts as a common conductor, connecting various electrical components like transformers and circuit breakers. It facilitates the efficient and reliable transfer of electrical power, and its configuration can be single, double, or ring bus, depending on the substation's design. The busbar operates at 33,000 volts and is equipped with isolators and circuit breakers for control and safety.

Lightning Arresters:

- Lightning arresters are installed to protect the substation equipment from lightning strikes by diverting the excess current to the ground.

-A lightning arrester, also known as a surge arrester or surge protector, is a device designed to protect electrical equipment and systems from voltage spikes caused by lightning strikes or other transient voltage events. In a 33kV (33,000 volts) substation, lightning arresters play a crucial role in safeguarding the substation equipment and the overall power system.



Here's an explanation of how a lightning arrester works and its role in a 33kV substation:

Purpose:

The primary purpose of a lightning arrester is to divert the high-voltage surges caused by lightning strikes away from sensitive electrical equipment. Lightning can cause extremely high voltages that can damage or destroy substation equipment, including transformers, circuit breakers, and other components. The lightning arrester provides a path of least resistance for these surges, preventing them from causing damage to the substation

Construction:

Lightning arresters are typically composed of a series of metal oxide varistors (MOV) connected in parallel. The varistors have a non-linear voltage-current characteristic, meaning that their resistance decreases as the voltage across them increases. This property allows them to conduct high voltages to the ground, effectively protecting the connected equipment.

Installation:

Lightning arresters are strategically installed at various points in the substation to provide comprehensive protection. Common locations include the entrance of the substation, near transformers, and at key points along transmission lines. The goal is to intercept and shunt the excessive voltage to the ground before it reaches and damages the substation equipment.

Operation:

During normal operating conditions, the lightning arrester presents a high impedance to the flow of power, allowing the electrical system to function without interference. When a voltage surge occurs, such as during a lightning strike, the varistors in the lightning arrester quickly become conductive, providing a low-resistance path for the surge to be safely discharged into the ground.

Control and Relay Panels:

- These panels house the protection and control devices for the substation. They include relays, meters, annunciator panels, and other control equipment.

In a 33kV (33,000 volts) substation, the control panel and relays play vital roles in monitoring, controlling, and protecting the electrical system. Let's delve into the functions and significance of the control panel and relays in such a substation:



Control Panel:

Function:

The control panel serves as the central hub for monitoring and controlling various components within the substation. It facilitates human-machine interaction and allows operators to oversee and manage the electrical equipment and processes.

Components:

- Control Devices: These include switches, indicators, and human-machine interface (HMI) devices that enable operators to control the substation equipment

Meters and Instruments: Instruments like voltage meters, current meters, and other indicators provide real-time data on the status of the electrical parameters within the substation.

Communication Equipment: Control panels often have communication devices for data exchange between the substation and the main control center.

Monitoring and Control:

Voltage and Current Control: Operators can adjust and control the voltage and current levels as needed to maintain a stable and efficient power supply.

Circuit Breaker Control: The control panel allows operators to open and close circuit breakers for isolating or connecting various parts of the substation.

- Alarm Systems: The control panel may incorporate alarms to notify operators of abnormal conditions or faults within the substation.



Automation:

- SCADA Systems: In more advanced setups, the control panel may be integrated with Supervisory Control and Data Acquisition (SCADA) systems. SCADA allows for remote monitoring and control of the substation.

Relays:

Function:

Relays are protective devices designed to detect abnormal conditions or faults in the electrical system and initiate appropriate actions to isolate the faulty section while maintaining continuity of service in the rest of the system.

Types of Relays:

- Over current Relays: Protect against excessive current in the system.

Distance Relays: Protect against faults based on the distance from the substation.

Differential Relays: Protect against internal faults by comparing currents at different points in the system.

Frequency Relays: Monitor the frequency of the electrical system.

Operation:

Detection: Relays continuously monitor electrical parameters. If an abnormal condition is detected, such as a fault, the relay triggers an alarm.

Isolation: In the event of a fault, the relay sends signals to circuit breakers to isolate the faulty section, preventing the fault from spreading to other parts of the system.

Coordination: Relays are coordinated to ensure that the nearest relay operates first to isolate the fault quickly.

Testing and Maintenance:

Relays require regular testing to ensure their proper functioning during fault conditions.

Maintenance involves checking and calibrating the relay settings and replacing any faulty components.

Earthing System:

- A proper earthing system is essential for the safety of personnel and equipment. It includes grounding electrodes, conductors, and connections to ensure a low-resistance path to the ground.



- In an electrical power system, a substation plays a crucial role in transforming and distributing electricity. Proper earthing in a substation is essential for ensuring the safety of personnel, protecting equipment, and maintaining the reliability of the power system. Here's an explanation of 33kV substation earthing:

Purpose:

- **Safety:** Earthing provides a path for fault currents to flow safely into the ground, preventing electrical shocks and minimizing the risk of fires.
- **Equipment Protection:** Proper earthing ensures that equipment and structures remain at a stable potential, preventing damage due to lightning strikes, overvoltages, or other fault conditions.

33kV Substation Earthing:

Substation Layout:

Grid Layout: Involves a grid of conductive material (typically copper or aluminum) buried in the ground, forming a network.

Earth Mat: A conductive mesh of interconnected strips or rods buried in the soil beneath the substation.

Electrode System:

Earth Electrodes: Metal rods or plates buried in the ground to achieve low resistance to earth.

Counterpoise Conductors: Horizontal conductors buried near the surface to enhance the earth grid's performance.

Measurement and Testing:

- **Earth Resistance Testing:** Regular testing of the earth resistance to ensure it meets safety standards.
- **Step and Touch Voltage Testing:** Ensures that under fault conditions, step and touch potentials remain within safe limits.

Power Transformers:

- Power transformers step up or step down the voltage levels as required for transmission and distribution. They are crucial for voltage transformation and power transfer.

- A power transformer is a crucial electrical device used in the transmission and distribution of electrical energy. Its primary function is to transfer electrical energy between two or more circuits through electromagnetic induction. Power transformers play a pivotal role in the electricity supply chain, helping to step up voltage for efficient long-distance transmission and step-down voltage for safe distribution to end-users.



Basic Components:

Core: The core is typically made of laminated iron or steel sheets. Its primary purpose is to provide a low-reluctance path for the magnetic flux generated during operation.

Windings: There are two sets of windings in a power transformer—primary winding and secondary winding. The primary winding is connected to the input voltage source, while the secondary winding is connected to the output load. The windings are usually made of copper or aluminum.

Operation Principle:

When an alternating current (AC) flows through the primary winding, it creates a magnetic flux in the core due to the changing magnetic field.

This magnetic flux induces a voltage in the secondary winding through electromagnetic induction, and this induced voltage is proportional to the turns ratio of the windings.

Voltage Transformation:

Power transformers are used to either step up or step down the voltage level of the electrical energy. The turns ratio between the primary and secondary windings determines the voltage transformation.

Step-up transformers increase the voltage for long-distance transmission, reducing energy loss, while step-down transformers decrease the voltage for safer distribution to end-users.

Types of Power Transformers:

Distribution Transformers: Used for stepping down voltage levels for local distribution networks.

Power Transformers: Employed in high-voltage transmission systems for long-distance power transfer.

Instrument Transformers: Provide accurate measurement of current and voltage levels for protection and control systems.

Efficiency and Losses:

Power transformers are designed to be highly efficient to minimize energy losses during operation.

Transformer losses include core losses (hysteresis and eddy current losses) and copper losses (I^2R losses in the windings).



Cooling Systems:

Transformers generate heat during operation, and effective cooling is essential for their proper functioning. Cooling methods include natural convection, forced air, oil-immersed cooling, and more advanced methods like liquid cooling.

-Here the cooling System Is Air Natural Oil Natural.

Tap Changers:



- Tap changers are mechanisms that allow adjustments to the turns ratio, enabling fine-tuning of the output voltage to compensate for variations in the input voltage or load conditions.

An on-load tap changer (OLTC) is a device used in electrical power transformers to adjust the transformer's turns ratio while it is energized and in operation. The turns ratio determines the voltage transformation between the primary and

secondary windings of the transformer. The on-load tap changer allows for real-time adjustment of this ratio to regulate the output voltage.

By changing the tap position, the on-load tap changer helps maintain a consistent voltage level at the transformer's secondary terminals despite fluctuations in the input voltage or load conditions. This ensures a stable and reliable power supply to connected electrical devices.

The on-load tap changer is typically controlled by a mechanism that can be operated remotely or automatically, enabling adjustments without interrupting the transformer's operation. This capability is crucial for managing voltage variations and optimizing the performance of the power distribution system.

Tap-Changer Mechanism Specification:

| | |
|------------------------|------------|
| RATED VOLTAGE | 33kV |
| RATED THROUGH CURRENT | 200 AMPS |
| NO. OF STEPS | 16 |
| PHASE | 3 |
| WEIGHT WITHOUT OIL | 495 Kg. |
| CYCLES | 50Hz |
| OIL WEIGHT | 555Kg. |
| RATED STEP VOLTAGE | 412.5 |
| QTY. OF OIL | 640 liters |
| WORKING CURRENT | 58 AMPS |
| TOTAL WEIGHT | 1050 Kg. |
| RATED INSULATION LEVEL | 70kV |

Protection and Monitoring:

- Power transformers are equipped with protective devices and monitoring systems to ensure their safe operation. This includes temperature monitoring, Buchholz relay for oil-filled transformers, and overcurrent protection.

Power transformers are essential components of electrical infrastructure, facilitating the efficient and reliable transmission and distribution of electrical power across various regions. They come in various sizes and capacities, ranging from small distribution transformers in neighborhoods to large units in power substations.

Transformer Specification

| | |
|------------------|-----------|
| VOLTAGE RATING | 33Kv/11Kv |
| PEAK CURRENT | 200 AMPS |
| CAPACITY | 5MVA |
| INSULATION LEVEL | 70kV |

Switchgear:

- Switchgear includes various electrical devices such as circuit breakers, disconnectors, and fuses, used to control, protect, and isolate electrical equipment in the substation.

Switchgear in a 33kV (kilovolt) substation is essential for controlling and protecting the electrical power system. It is a combination of electrical disconnect switches, fuses, circuit breakers, and other devices used to control, protect, and isolate electrical equipment.

Auxiliary Power Supply:

- This includes transformers and equipment that provide power for the operation of control and protection devices within the substation.

Auxiliary supply refers to a secondary power source used to provide energy to supporting systems or devices within a larger apparatus or facility. It ensures the operation of essential components, such as control systems, monitoring devices,

and safety equipment, even if the main power source is disrupted. Common in various industries, auxiliary supply enhances the reliability and functionality of systems by maintaining critical functions during power interruptions.

Fire Protection and Safety Equipment:

- Fire extinguishers, alarms, and other safety equipment are installed to ensure the safety of personnel and equipment in case of emergencies.

Safety in a 33kV substation involves:

- Wearing proper PPE.
- Ensuring trained and qualified personnel.
- Implementing isolation and LOTO procedures.
- Maintaining clearances and barriers.
- Proper grounding practices.
- Establishing emergency procedures
- Regular equipment maintenance.
- Periodic inspection and testing.
- Conducting safety audits.
- Clear communication protocols.
- PPE used for HT handling



11kV Switchyard



Power Supply:

Source: The power supply comes from the secondary side of three transformers. This secondary side typically refers to the output side of a transformer, where the voltage is transformed to a desired level for distribution.

Voltage: The supplied voltage from the transformers' secondary side is 11kV. This indicates that the power distributed in the switchyard is at a voltage level of 11 kilovolts.

- it is provided to 11kV switchyard through the 11kV Underground Cables.

Transformers:

Quantity: There are three transformers in the setup, named Transformer-1, Transformer-2, and Transformer-3. Transformers are devices that step up or step-down voltage levels as needed in an electrical distribution system.

Distribution: Transformer-1 and Transformer-2 supply power to individual busbars. Transformer-3 supplies power to two busbars, one of which is dedicated to an express feeder for companies requiring 11kV supply. This configuration allows for flexibility and redundancy in the distribution system.

Busbars:

Number of Buses: There are four busbars in the 11kV switchyard. Busbars are conductors or bars that serve as a common connection point for incoming and outgoing electrical circuits.



Distribution of Busbars:

Transformer-1's Bus: One busbar.

Transformer-2's Bus: One busbar.

Transformer-3's First Bus: One busbar.

Transformer-3's Second Bus: One busbar

Feeders:

Total Feeders: Each bus has three feeder lines. Feeders are the conductors that carry electrical power from a source to a distribution point.

Distribution of Feeders:

Transformer-1's Bus Feeders:

Feeder 1: Goes to Bhojar.

Middle Feeder: Extra.

Third Feeder: Goes to a Pole Mounted 11kV / 440V substation.

Transformer-2's Bus Feeders:
Middle Feeder: Extra.
Remaining Two Feeders: Go to 11kV / 440V pole-mounted substations.
Transformer-3's First Bus Feeders:
Two Extra Feeders.
One Feeder: Goes to 11kV / 440V substation.
Transformer-3's Second Bus Feeders:
Feeder 1: Goes to Bajaj.
Feeder 2: Goes to a company.
Third Feeder: Extra.



Measurement and Control:

Current Transformers (CT): These devices are installed on each incoming and outgoing feeder to the bus for current measurement. CTs step down the current to a level suitable for metering and protection devices.
Potential Transformers (PT): Installed on each incoming and outgoing feeder to the bus for voltage measurement. PTs step down the voltage to a level suitable for metering and protection devices.
Vacuum Circuit Breakers (VCB): These circuit breakers are installed between each feeder and the bus for control and protection. They interrupt the current flow in case of a fault or for maintenance purposes.



Consumer Feeder Details:
11kV Consumer Bus (Transformer-3's Second Bus):
Feeder 1: Goes to Bajaj.
Feeder 2: Goes to a company.
Third Feeder: Extra. This arrangement indicates the distribution of power to specific consumer entities.

Metering:

Metering System: Information from CT and PT is fed into meters for recording readings. These meters provide data on current and voltage levels at different points in the distribution network.

Purpose: The metering system plays a crucial role in monitoring and recording electrical parameters, enabling operators to assess the performance of the distribution system and diagnose any issues that may arise.



This detailed breakdown provides a comprehensive understanding of the 11kV switchyard setup, highlighting the role and significance of each component in the distribution network.



II. CONCLUSION

The 33/11kV Substation in Lohara MIDC, Yavatmal, operated by Maharashtra State Electricity Distribution Co. Ltd., plays a pivotal role in ensuring a reliable and efficient power supply to the region. This vital infrastructure serves as a critical link in the electricity distribution network, facilitating the transformation and distribution of power to meet the

demands of industrial, commercial, and residential consumers. The strategic location of the substation in the MIDC area underscores its significance in supporting the industrial activities and economic development of the region. The 33/11kV Substation not only enhances the quality of power supply but also contributes to the overall growth and prosperity of Yavatmal and its surrounding areas. The commitment of Maharashtra State Electricity Distribution Co. Ltd. to maintain and upgrade this substation demonstrates a forward-looking approach to meet the evolving energy needs of the community. As technology advances and energy requirements grow, the substation serves as a resilient hub that adapts to these changes, ensuring a stable and secure power supply for the foreseeable future. In essence, the 33/11kV Substation in Lohara MIDC, Yavatmal, stands as a testament to the dedication of Maharashtra State Electricity Distribution Co. Ltd. in providing reliable electricity services. It not only contributes to the socio-economic development of the region but also exemplifies the utility's commitment to delivering sustainable and high-quality power solutions to its consumers.