

Autonomous Robot for Pesticide Application and Harvest Transport, Controlled through an Android Application

Mr. Pradeshi Krishna¹, Mr. Tirmakhe Vishal, Mr. Gaikwad Rahul³,

Miss. Bansode Dnyaneshwari⁴, Prof. Abhale B. A.⁵

SND College of Engineering and Research Centre, Yeola, Maharashtra, India

Abstract: *The project aims to develop a smart farming solution that integrates autonomous pesticide spraying and crop harvesting, managed through a user-friendly Android application. In essence, it seeks to create a robot capable of automating two critical farm tasks. This innovative technology is poised to boost agricultural efficiency by automating both pesticide application and crop harvesting processes. Equipped with advanced features like autonomous navigation, the robot can navigate the farm autonomously, saving time for farmers and ensuring precise spraying and harvesting. Integration with an Android application provides farmers with an intuitive interface to control and monitor the robot. This project envisions a sustainable, technology-driven farming approach, reducing manual labor for pesticide application and crop harvesting. With this robot, farmers can anticipate heightened productivity, improved crop yields, and a more streamlined farming experience. The initiative aligns with the objective of advancing agricultural practices through automation, benefiting farmers and the farming ecosystem as a whole.*

Keywords: Autonomous, Pesticide spraying, Harvest Transport Robot, Android application.

I. INTRODUCTION

In the rapidly evolving realm of modern agriculture, the integration of cutting-edge technologies has become essential to meet the growing global demand for food production. One such innovation poised to revolutionize traditional farming practices is the development of autonomous robotic systems. This study centers on designing and creating an advanced agricultural robot tailored specifically for tasks such as pesticide spraying and harvest transport, all seamlessly controlled through an intuitive Android application.

Conventional farming methods often encounter difficulties stemming from labor shortages, inefficient resource utilization, and the environmental repercussions of excessive pesticide usage. In response to these challenges, autonomous agricultural robots have emerged as a promising solution to enhance efficiency, diminish reliance on human labor, and optimize resource allocation. This research project aims to contribute to this transformative shift by designing a state-of-the-art robot capable of autonomously performing crucial tasks in agriculture. The proposed robot will not only address the need for precise and targeted pesticide application but also introduce a novel approach to harvest transport, streamlining the harvesting process and minimizing post-harvest losses. Additionally, the integration of an Android application for remote control and monitoring aims to provide farmers with unprecedented flexibility and real-time insights into their agricultural operations.

This research endeavors to explore the technical intricacies involved in designing and developing an autonomous agricultural robot, considering factors such as navigation, obstacle avoidance, precision in pesticide dispensing, and efficient harvest transport mechanisms. Through this exploration, it seeks to contribute to sustainable farming practices, economic viability, and environmental conservation, ushering in a new era of smart and efficient agriculture.

Through this research, we embark on a journey to leverage the power of robotics and mobile technology to revolutionize agriculture, paving the way for a more resilient and productive future in addressing global food security challenges

II. PURPOSE

The purpose of the above text is to outline the goals and objectives of a research project focused on designing and developing an autonomous agricultural robot. It highlights the intended contributions of the project towards transforming traditional farming practices, enhancing efficiency, and addressing challenges in agriculture such as labor shortages and environmental impact. Additionally, it emphasizes the incorporation of cutting-edge technologies, such as robotics and mobile applications, to revolutionize agricultural operations and pave the way for a more sustainable and productive future.

III. OBJECTIVE OF SYSTEM

The objective of the project is to design and develop an autonomous robot capable of efficiently applying pesticides and transporting harvested crops on farms. The robot will be controlled through an Android application, providing farmers with a user-friendly interface for remote monitoring and operation. Through this initiative, the aim is to enhance agricultural efficiency, reduce labor requirements, and optimize resource utilization in pesticide application and crop transportation processes.

IV. PROPOSED SYSTEM

The project aims to improve precision and accuracy in pesticide application, thereby minimizing environmental impact and maximizing crop yields. By integrating advanced features such as autonomous navigation and obstacle avoidance, the objective is to create a versatile robot capable of navigating farm terrain and performing tasks autonomously. Furthermore, the Android application will provide real-time insights into farming operations, allowing farmers to make informed decisions and optimize their workflow. Overall, the objective is to create a comprehensive solution that addresses key challenges in modern agriculture while promoting sustainability and productivity.

- **Manual Spraying:** Historically, farmers have relied on handheld sprayers or backpack sprayers to manually apply pesticides to crops. This method is labour-intensive and may result in uneven distribution, leading to overuse or underuse of pesticides.
- **Tractor-Mounted Sprayers:** Larger farms often utilize tractor-mounted sprayers, which cover more ground than manual methods. However, these still require human operation and can be less precise in targeting specific areas, leading to potential environmental concerns and increased pesticide usage.

SYSTEM ARCHITECTURE

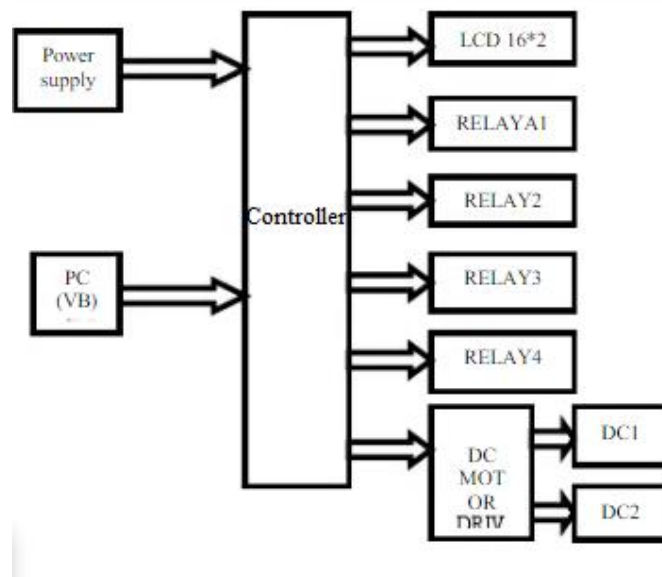

The basic block diagram, shown above depicts the arrangement of devices for the project. The power supply regulator block converts the electricity provided externally into a usable magnitude for the microcontroller and other assembly. The water motors and DC motors interfaced to the microcontroller through an relay circuit.. A display unit and interfacing unit which actually consists of LCD for displaying project name and output of different models connected to the microcontroller can be connected externally to the microcontroller A personal computer can be interfaced with the microcontroller for programming and for giving actual command to model

V. CONCLUSION

The successful integration of autonomous robotic systems in agriculture holds the potential to transform crop management, boost productivity, and contribute to the global transition towards more sustainable and technology-driven farming methods. The autonomous robot, guided by an Android application, ensures precise and efficient pesticide spraying and crop harvesting. The development of a smart and autonomous robot capable of pesticide spraying and crop harvesting, all managed through a user-friendly Android application, introduces new possibilities for precision farming. Incorporating a solar power system adds an environmentally friendly aspect, reducing dependence on traditional energy sources. Looking ahead, the project lays the foundation for further advancements in autonomous agricultural robotics. The principles and technologies developed have the potential for broader applications in the agriculture sector, promoting increased productivity, optimized resource utilization, and reduced environmental impact. Overall, the "Design and Development of Autonomous Pesticide Spraying and Harvest Transport Robot controlled by Android Application" project represents a significant step towards the future of intelligent and sustainable farming practices.

VI. ACKNOWLEDGMENT

We express our heartfelt gratitude to our esteemed mentors and professors, especially, for their invaluable guidance in our academic and project endeavours. We also extend our thanks to the *COMPUTER ENGINEERING* Department and its staff for their continuous support. Our sincere thanks go for his support and permission to complete this project. We appreciate the assistance of our department's support staff, and we're grateful to our parents, friends, and all those who supported us throughout this project.

REFERENCES

- [1]. N. R. Dhumale, P.C. Bhaskar, 2021 International Conference on Emerging Smart Computing and Informatics (ESCI), "Smart Agricultural Robot for Spraying Pesticide with Image Processing based Disease Classification Technique"
- [2]. Sami Salama Hussien Hajjaj, Kisheem Rao Gsangaya Afif Shazwan Abdul Ghafar, et al., 2021, Materials Today: Proceedings xxx (xxxx) xxx "Design and development of a robot for spraying fertilizers and pesticides for agriculture"
- [3]. Kalpana Murugan, A. Sumanth, B. Jaya Shankar, C. Venkata Sudharshan, G. Vigandhar Reddy, 2020, Vol. 11, No. 2, 3rd International Conference on Intelligent Sustainable Systems (ICISS) 9781728170893/20/\$31.00 © 2020 IEEE DOI: 10.1109/ICISS49785.2020.9316064 AISSMS Institute of Information Technology, Pune, India. Mar 5-7, 2021, "Smart Automated Pesticide Spraying Bot"
- [4]. A.M. Kassim, M.F.N. M. Termenzai, A.K.R.A. Jaya, A.H. Jaya, A.H. Azahar. (IJACSA) Vol. 11, No. 2, 2020, International Journal of Advanced Computer Science and Applications, "Design and Development of Autonomous Pesticide Sprayer Robot for Fertigation Farm"
- [5]. H. Chadalavada, N. Bharathkumar, P. Shaila et al. 2020, Materials Today: Proceedings xxx (xxxx) xxx srujan "Solar powered semi-automated multipurpose agriculture machine"
- [6]. Redmond Ramin Shamshiri, Cornelia Weltzien, Ibrahim A. Hameed, Ian J. Yule, Tony E. Grift, Siva K. Balasundram, Lenka Pitonakova, Desa Ahmad, Girish Chowdhary July, 2018, Int J Agric & Biol Eng Open Access at <https://www.ijabe.org> Vol. 11 No. 4 1, Research and development in agricultural robotics: A perspective of digital farming,
- [7]. Umesh B. Pawar, Sunil G. Bhirud, Satish R. Kolhe 2019 DOI: 10.1007/978-981-32-9515-5_16, Advances in Intelligent Systems and Computing