

# Fruit Degradation Detection System using CMOS Color Sensor

**Prof. Shashant Jaykar<sup>1</sup>, Ritika Umap<sup>2</sup>, Shruti Shende<sup>3</sup>, Kalyani Hood<sup>4</sup>**  
Faculty, Department of Electronics and Telecommunication Engineering<sup>1</sup>  
Students, Department of Electronics and Telecommunication Engineering<sup>2,3,4</sup>  
Rajiv Gandhi College of Engineering and Research, Nagpur, Maharashtra, India

**Abstract:** *Fruits and vegetables have been a significant part of the human diet for the last many years. In the modern age, with the increase in disease variants, people have become more curious about natural and organic nutrition. In this current situation the thought has brought some problems with it which are mostly related to freshness. The awareness about consuming organic fruit has been highly increased in people and the major reason behind this awareness is the discoveries about health benefits of fruits and vegetables. There are several parameters that affect the freshness of fruit such as temperature, humidity, growth of micro-organisms whose effects are not visible with naked eyes but are highly dangerous and As fruits and vegetables are very good source of food for us and they are also good source of energy for microorganisms like bacteria and fungi too. We preferred developing a simplified system which will provide us with a similar amount of accuracy which is being provided by various color measuring instruments such as spectrophotometers and computer vision with digital cameras. This provoked us to develop the project consisting of PIC Microcontroller and Color Sensor TCS3200 which not only overcomes the drawbacks of the existing systems but also helps to increase the accuracy and keeps the database for future detections.*

## I. INTRODUCTION

It is important for every human being to look for freshness in all vegetables and fruits we consume. By checking the characteristic signs of freshness such as bright color in the vegetable and fruits and look to see if the vegetable is free of soft spots.

Color and texture are the basic character of natural food items, and plays an important role in visual perception. Color is one of the most important property in identifying objects quality. The process of color classification involves extraction of useful information concerning the spectral properties of object surfaces and discovering the simplest match from a group of known descriptions or class models to implement the recognition task

The ability of a camera to record spectra would be an excellent advantage in designing an easy spectroscope. The images might be saved, manipulated, and displayed on a computer. This approach has been reported previously, where the spectrum image was printed and measured manually. However, with fully digital methods, wavelength measurements are often more precise and faint spectral lines are often detected. In this article, we describe a spectroscope design intended to be used with a color sensor and TCS3200 and a PIC Microcontroller. The spectroscope is mounted on an adjustable support, also made by using electronics components, to align its position relative to the camera and tripod. We also demonstrate that the spectroscopes are often calibrated and, in turn, are often used as a spectrophotometer.

## II. OBJECTIVE

The main objective is to build a cost effective system by using some of the electronic devices such as PIC microcontroller and colour sensor to give more accurate results than the present systems are available. This system will also reduce the hand work for a human being and can give more productivity.

**III. BLOCK DIAGRAM**

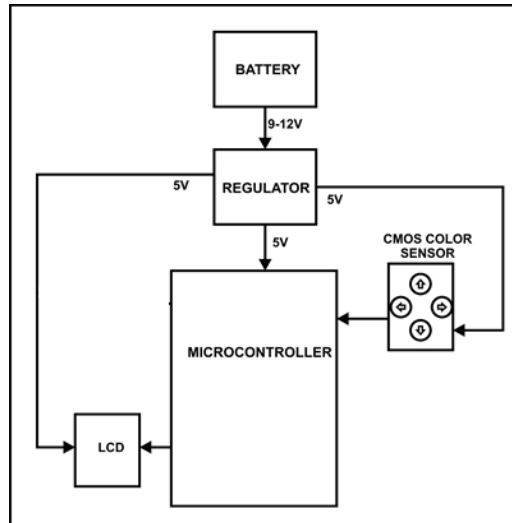

System uses a Power Supply of 9-12v which will give the continuous power to the circuit, It is also having a regulator circuitry which will protect the other components due to power surges. The main component are the CMOS Colour Sensor 8\*8 which can detect the primary colour which will give the more accurate results. A PIC microcontroller is used to perform the logical operations. A 16\*2 LCD to Display the output and a wireless module which will help to store the data in database and also used as a switch for the circuitry

**IV. CIRCUIT DIAGRAM**

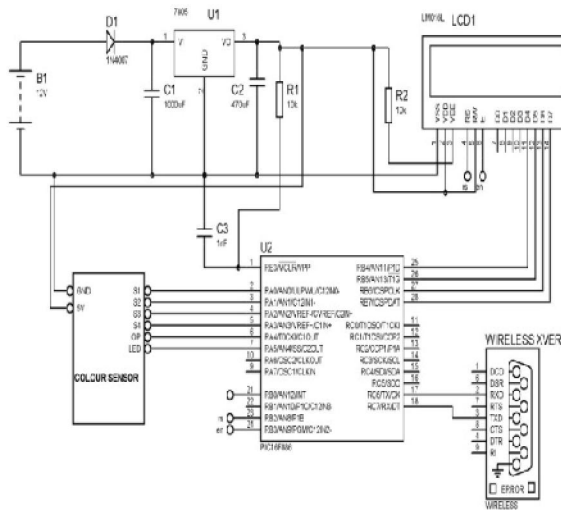

**V. COMPONENTS**

1. PIC16F888
2. LCD Module LM016L
3. CMOS color sensor (8\*8 matrix)
4. IC 7805 Voltage Regulator
5. 12v Battery

6. 1N404 Diode
7. Capacitor 1000uf
8. Capacitor 470uf
9. Resistor 10Kohms (2)

## **VI. IMPLEMENTATION**

The Implementation Plan describes how the information system will be deployed, installed and transitioned into an operational system. The plan contains an overview of the system, a brief description of the major tasks involved in the implementation, the overall needed to support the implementation effort (such as hardware, software, facilities, and personnel), and any site-specific implementation requirements. The plan is ended during the Design Phase and is updated during the Development Phase; the final one is provided in the Integration and Test Phase and is used for guidance during the Implementation Phase.

### **6.1 PCB Designing, Etching and Printing**

A **printed circuit board (PCB)** is mechanically supports and electrically connects electronic components using conductive tracks, pads and other features etched from one or more sheet layers of copper laminated onto and/or between sheet layers of a non-conductive substrate. Components are generally soldered onto the PCB to both electrically connect and mechanically fasten them to it.

### **6.2 PCB Drilling Process**

Once all the holes are drilled the operator unloads the panels from the drilling machine and discards the entry and exit material.

### **6.3 Soldering**

Soldering is a process in which two or more items are joined together by melting and putting a filler metal (solder) into the joint, the filler metal having a lower melting point than the adjoining metal. Unlike welding, soldering does not involve melting the work pieces. In brazing, the work piece metal also does not melt, but the filler metal is one that melts at a higher temperature than in soldering. In the past, nearly all solders contained lead, but environmental and health concerns have increasingly dictated use of lead-free alloys for electronics and plumbing purposes.

### **6.4 Interfacing Hardware**

Interface all modules as per the circuit diagram with the help of connecting wires

## **VII. RESULT**

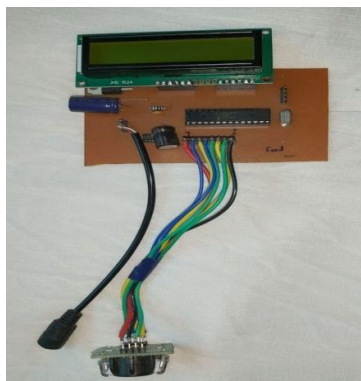

**REFERENCES**

- [1] Ahuja, T., Mir, I.A., Kumar, D., Rajesh, 2007. Biomolecular immobilization on conducting polymers for biosensing applications. *Biomaterials* 28, 791–805.
- [2] Ahvenainen, R., 2003. Active and intelligent packaging: an introduction. In: Ahvenainen, R. (Ed.), *Novel Food Packaging Techniques*. Woodhead Publishing Ltd., Cambridge, pp. 5–21.
- [3] Ahvenainen, R., 2003. Active and intelligent packaging: an introduction. In: Ahvenainen, R. (Ed.), *Novel Food Packaging Techniques*. Woodhead Publishing Ltd., Cambridge, pp. 5–21.
- [4] Akyildiz, I., Jornet, J., 2010. The internet of nano-things. *IEEE Wirel. Commun.* 17, 58–63. Alcilja, E.C., Radke, S.M., 2003.
- [5] Electrochemical biosensor based on gold coated iron nanoparticles/chitosan composite bound xanthine oxidase for detection of xanthine in fish meat. *J. Food Eng.* 115 (2), 207–214. <https://doi.org/10.1016/j.jfoodeng.2012.10.014>.